

**UNIT MAINTENANCE MANUAL, INCLUDING
REPAIR PARTS AND SPECIAL TOOLS LIST (RPSTL) FOR**

**ANCILLARY EQUIPMENT FOR:
PERSONNEL TROOP PARACHUTE SYSTEM**

**CASE, PARACHUTISTS, INDIVIDUAL WEAPON, M-1950 (NYLON)
(NSN: 8465-01-109-0702)**

**CASE, PARACHUTISTS, INDIVIDUAL WEAPON, M-1950 (COTTON)
(NSN: 8465-00-261-4995)**

**CASE, PARACHUTISTS, WEAPON & INDIVIDUAL EQUIPMENT
(NSN: 8465-00-753-6549)**

**EXTENSION, STATIC LINE, STANDARD, 5-FOOT (NSN: 1670-00-368-4225)
ACCESSORY, SET SCUBA, (NSN: 1670-00-064-5735)
LINE, LOWERING, 15-FOOT (NSN: 1670-01-067-6838)
JUMP, PACK, DRAGON MISSILE, (NSN: 1670-01-035-7727)
HARNESS, SINGLE POINT RELEASE, (NSN: 1670-01-227-7992)
PACK, ASSEMBLY, AT4, (NSN: 1670-01-259-5932)
JUMP, PACK, STINGER MISSILE, (NSN: 1670-01-352-9264)
RELEASE ASSEMBLY, (NSN: 1670-01-415-0035)**

**CONTAINER, FRONT MOUNT (AIRPAC) (NSN: 1670-01-414-2757)
CONTAINER, SIDE MOUNT (AIRPAC) (NSN: 1670-01-413-7836)
DROP BAG, PARACHUTE, W/7-FOOT LOWERING LINE
(1670-01-508-9051)
DROP BAG, PARACHUTE, W/15-FOOT LOWERING LINE
(1670-01-508-9053)**

DISTRIBUTION STATEMENT A – Approved for public release; distribution is unlimited.

*This manual supersedes TM 10-1670-299-20&P, 15 September 1995.

HEADQUARTERS, DEPARTMENT OF THE ARMY

30 JUNE 2004

WARNING SUMMARY

This warning summary contains general safety warnings and hazardous materials warnings that must be understood and applied during operation of this equipment. Failure to observe these precautions could result in serious injury or death to personnel. Also included are explanations of safety and hazardous materials icons used within this technical manual.

EXPLANATION OF SAFETY WARNING ICONS



BIOLOGICAL - abstract symbol bug shows that a material may contain bacteria or viruses that present a danger to life or health.



CHEMICAL - drops of liquid on hand shows that the material will cause burns or irritation to human skin or tissue.



CRYOGENIC - hand in block of ice shows that the material is extremely cold and can injure human skin or tissue.



ELECTRICAL - electrical wire to arm with electricity symbol running through human body shows that shock hazard is present.



EXPLOSION - rapidly expanding symbol shows that the material may explode if subjected to high temperatures, sources of ignition or high pressure.



EYE PROTECTION - person with goggles shows that the material will injure the eyes.



FALLING PARTS - arrow bouncing off human shoulder and head shows that falling parts present a danger to life or limb.



FIRE - flame shows that a material may ignite and cause burns.



HEAVY OBJECT - human figure stooping over heavy object shows physical injury potential from improper lifting technique.



HEAVY PARTS - heavy object on human figure shows that heavy parts present a danger to life or limb.



HOT AREA - hand over object radiating heat shows that part is hot and can burn.

TM 10-1670-299-20&P



POISON - skull and crossbones shows that a material is poisonous or is a danger to life.



SHARP OBJECT - pointed object in hand shows that a sharp object presents a danger to limb.



SLICK FLOOR - wavy line on floor with legs prone shows that slick floor presents a danger for falling.



VAPOR - human figure in a cloud shows that material vapors present a danger to life or health.

GENERAL SAFETY WARNINGS DESCRIPTION

WARNING

The lowering line retainer/stow pocket must have the hook and pile closures on both ends of the pocket. Failure to insure that the retainer ends are securely closed could result in premature lowering line release, causing serious injury or death.

WARNING

Death could result if inspections are not performed as specified in this manual. Perform all inspections as specified.



WARNING

Exercise extreme care when using petroleum products to destroy equipment by fire, as these materials are highly flammable. Improper handling may cause injury to personnel.

WARNING

Failure to detect areas of damage may result in malfunction of the parachute and injury or loss of life to personnel.

WARNING

For First Aid treatment, refer to FM 4-25.11.

TM 10-1670-299-20&P

INSERT LATEST CHANGED PAGES / WORK PACKAGES. DESTROY SUPERSEDED DATA

LIST OF EFFECTIVE PAGES / WORK PACKAGES

NOTE: The portion of text affected by the changes is indicated by a vertical line in the outer margins of the page. Changes to illustrations are indicated by miniature pointing hands. Changes to wiring diagrams are indicated by shaded areas.

Dates of issue for original and changed pages / work packages are:

Original 0.... 30 Jun 04

TOTAL NUMBER OF PAGES FOR FRONT AND REAR MATTER ARE 30 AND TOTAL NUMBER OF WORK PACKAGES IS 53 CONSISTING OF THE FOLLOWING:

Page / WP No.	* Change No.
Front Cover	0
a-b	0
A-(B Blank)	0
i-v/(vi Blank)	0
WP 0001 00 – 0053	0
Index 1- Index 4	0
Authentication Page	0
Electronic 2028 Inst	0
Sample DA Form 2028	0
Blank DA Form 2028	0
Back Cover	0

*Zero in this column indicates an original page or work package

A/(B Blank)

***ARMY TM 10-1670-299-20&P
AIR FORCE TO 14D1-2-470-2
NAVAIR 13-1-41**

HEADQUARTERS
DEPARTMENT OF THE ARMY
WASHINGTON, D.C., 30 JUNE 2004

**UNIT MAINTENANCE MANUAL
INCLUDING REPAIR PARTS AND SPECIAL TOOLS LIST**

ANCILLARY EQUIPMENT FOR: PERSONNEL TROOP PARACHUTE SYSTEM

CASE, PARACHUTISTS, INDIVIDUAL WEAPON, M-1950 (NYLON), (NSN: 8465-01-109-0702)
CASE, PARACHUTISTS, INDIVIDUAL WEAPON, M-1950 (COTTON)(NSN: 8465-00-261-4995)
CASE, PARACHUTISTS, WEAPON & INDIVIDUAL EQUIPMENT, (NSN: 8465-00-753-6549)
EXTENSION, STATIC LINE, STANDARD, 5-FOOT (NSN: 1670-00-368-4225)
ACCESSORY, SET SCUBA, (NSN: 1670-00-064-5735)
LINE, LOWERING, 15-FOOT (NSN: 1670-01-067 6838)
JUMP, PACK, DRAGON MISSILE, (NSN: 1670-01-035-7727)
HARNES, SINGLE POINT RELEASE, (NSN: 1670-01-227-7992)
PACK, ASSEMBLY, AT4, (NSN: 1670-01-259-5932)
JUMP, PACK, STINGER MISSILE, (NSN: 1670-01-352-9264)
RELEASE ASSEMBLY, (NSN: 1670-01-415-0035)
CONTAINER, FRONT MOUNT (AIRPAC) (NSN: 1670-01-414-2757)
CONTAINER, SIDE MOUNT (AIRPAC) (NSN: 1670-01-413-7836)
DROP BAG, PARACHUTE, W/7-FOOT LOWERING LINE
(1670-01-508-9051)
DROP BAG, PARACHUTE, W/15-FOOT LOWERING LINE
(1670-01-508-9053)

REPORTING ERRORS AND RECOMMENDING IMPROVEMENTS

ARMY

You can help improve this manual. If you find any mistakes or if you know of a way to improve the procedures, please let us know. Mail your letter together with DA Form 2028 (Recommended Changes to Publications and Blank Forms), or DA Form 2028-2, located in the back of this manual, directly to: Commander, US Army Tank-automotive & Armament Command, ATTN: AMSTA-LC-CECT, Kansas Street, Natick, MA 01760. You may also send in your recommended changes by email directly to amssbriml@natick.army.mil. A reply will be furnished to you. Instructions for sending an electronic 2028 may be found at the back of this manual immediately preceding the hard copy 2028.

AIR FORCE

Reports by U.S. Air Force units should be submitted on AFTO Form 22 (Technical Order Publication Improvement Report and Reply) and forwarded to the address prescribed above for the Army. An information copy of the prepared AFTO Form 22 shall be furnished to WP-ALC/TILTA, 420 2nd Street, Suite 100, Robins AFB, GA 31098-1640.

MARINE CORPS

Marine Corps personnel submit NAVMC 10772 form to Commander, ATTN: (Code 850), Marine Corps Logistics Bases, 814 Radford Blvd., Albany, GA 31704-1128.

NAVY

Submit NAVSEA form 4160/1 (REV 2-99) to Commander, NSDSA Code 5E30, NAVSURFCENDIV, 4363 Missile Way, Port Hueneme, CA 93043-4307. A reply will be sent to you.

DISTRIBUTION STATEMENT A – Approved for public release. Distribution is unlimited.

*This manual supersedes TM 10-1670-299-20&P, 15 September 1995.

TABLE OF CONTENTS

WP Sequence No.

WARNING SUMMARY

HOW TO USE THIS MANUAL

GENERAL INFORMATION..... 0001 00

CHAPTER 1. DESCRIPTION AND THEORY OF OPERATION

Equipment Description and Data 0002 00
 Theory of Operation 0003 00

CHAPTER 2. UNIT MAINTENANCE

Service Upon Receipt 0004 00
 Preventative Maintenance Checks and Services (PMCS), Introduction..... 0005 00
 Unit Preventative Maintenance Checks and Services (PMCS) 0006 00
 Unit Maintenance, Introduction 0007 00
 Inspection..... 0008 00
 Cleaning and Drying 0009 00
 Airing 0010 00
 Salt/Fresh-Water Contamination Test 0011 00
 Sewing Procedures..... 0012 00
 Searing and Waxing..... 0013 00
 Marking and Restenciling..... 0014 00
 Snap Fastener and Grommets 0015 00
 5-Ft Extension Static Line, Standard 0016 00
 Accessory Set, SCUBA..... 0017 00
 Line, Lowering..... 0018 00
 Jump Pack, Dragon Missile 0019 00
 Harness, Single Point Release 0020 00
 Pack Assembly, AT4 0021 00
 Case, Parachutist's Individual Weapon M-1950 (Cotton)..... 0022 00
 Case, Parachutist's Individual Weapon M-1950 (Nylon) 0023 00
 Parachutist's Weapons and Individual Equipment Pack and Harness Assembly 0024 00
 Jump Pack, Stinger Missile..... 0025 00
 Release Assembly 0026 00
 Container, Front Mounted 0027 00
 Container, Side Mounted 0028 00
 Parachute Drop Bag (PDB)..... 0029 00
 Preparation for Storage..... 0030 00
 Preparation for Shipment..... 0031 00

CHAPTER 3. SUPPORTING INFORMATION

References..... 0032 00
 Maintenance Allocation Chart - Introduction..... 0033 00

TABLE OF CONTENTS – continued

Maintenance Allocation Chart (MAC)	0034 00
Repair Parts And Special Tools List (RPSTL) Introduction	0035 00
Repair Parts And Special Tools List – Extension, Static Line, Standard, 5-Foot	0036 00
Repair Parts And Special Tools List – Accessory Set, SCUBA.....	0037 00
Repair Parts And Special Tools List – Line, Lowering, 15-Foot	0038 00
Repair Parts And Special Tools List – Jump Pack, Dragon Missile	0039 00
Repair Parts And Special Tools List – Harness, Single Point Release	0040 00
Repair Parts And Special Tools List – Pack, Assembly, AT4	0041 00
Repair Parts And Special Tools List – Case, Parachutist’s Individual Weapon, M-1950, Cotton	0042 00
Repair Parts And Special Tools List – Case, Parachutist’s Individual Weapon, M-1950, Nylon	0043 00
Repair Parts And Special Tools List – Parachutist’s Weapons and Individual Equipment and Harness Assembly	0044 00
Repair Parts And Special Tools List – Jump Pack, Stinger Missile	0045 00
Repair Parts And Special Tools List – Release, Parachutist’s, Individual Equipment.....	0046 00
Repair Parts And Special Tools List – Container, Front Mount	0047 00
Repair Parts And Special Tools List – Container, Side Mount	0048 00
Repair Parts And Special Tools List – Parachute Drop Bag.....	0049 00
National Stock Number Index	0050 00
Part Number Index	0051 00
Expendable and Durable Item Index.....	0052 00
Illustrated List of Manufactured Items	0053 00
ALPHABETICAL INDEX	Index-1

HOW TO USE THIS MANUAL

This Technical Manual contains General Information, Unit Maintenance Instructions, Preventive Maintenance Checks and Services (PMCS), Troubleshooting, and Maintenance Information for the Ancillary Equipment For: Personnel Troop Parachute System.

Chapter 1 contains introductory information on the Ancillary Equipment For: Personnel Troop Parachute System and any associated equipment as well as a Location and Description of Major Components. Chapter 2 contains service upon receipt, initial receipt, receipt of used parachute assembly, and preventative maintenance checks and services information and instructions. Chapter 2 also contains maintenance procedures authorized at the unit level. Chapter 3 contains references, expendable durable items list, maintenance allocation chart, repair parts and special tolls list, national stock number index, part number index, and illustrated list of manufactured items. Rear matter consists of alphabetical index, DA Form 2028, authentication page, and back cover.

Manual Organization and Page Numbering System. The Manual is divided into three major chapters that detail the topics mentioned above. Within each chapter are work packages covering a wide range of topics. Each work package is numbered sequentially starting at page 1. The work package has its own page numbering scheme and is independent of the page numbering used by other work packages. Every work package has an even number of pages so that it does not interfere with any other work package. Each page of a work package has a page number of the form XXXX YY-ZZ where “XXXX” is the work package number (e.g. 0010 is work package 10). “YY” is a number that allows for a work package to be inserted between two existing work packages without disturbing the remainder of the TM (e.g. WP 0010 01 would fall between WP 0010 and WP 0011). “ZZ” represents the number of the page within that work package. A page number such as 0010 00-1/(2 Blank) means that page 1 contains information but page 2 of that work package has been intentionally left blank. A page number such as 0010 00-(1 Blank)/2 means that page 1 of that work package has been intentionally left blank but page 2 contains information.

Illustrations. Illustrations for procedures in this manual always follow the procedure. For example, if given a procedural instruction such as “1. Locate the main canopy (1).”, the (1) references the photo or illustration immediately *following* the procedure.

Finding Information. The Table of Contents permits the reader to find information in the manual quickly. The reader should start here first when looking for a specific topic. The Table of Contents lists the topics contained within each chapter and the work package sequence number where it can be found.

Example: If the reader were looking for instructions on “The 5-FT Static Line Extension”, which in this manual is a Unit Maintenance topic, the Table of Contents indicates that Unit Maintenance information can be found in Chapter 2. Scanning down the listings for Chapter 2, “The 5-FT Static Line Extension” information can be found in WP 0016 00 (i.e. Work Package 16).

An Alphabetical Index can be found at the back of the manual. It lists specific topics with the corresponding work package.

UNIT MAINTENANCE
ANCILLARY EQUIPMENT FOR PERSONNEL PARACHUTE SYSTEMS
GENERAL INFORMATION

SCOPE

This manual contains an equipment description, operating instructions and maintenance procedures for Ancillary Equipment for Personnel Troop Parachute Systems. This manual also provides a Repair Parts and Special Tools List, located in WP 0035 00 through WP 0049 00.

Purpose of Equipment. The Ancillary Equipment for Personnel Troop Parachute System provides a capability to safely deliver an airborne soldier, and individual equipment, from an aircraft in flight, for a vertical assault on an enemy.

MAINTENANCE FORMS AND PROCEDURES

Department of the Army forms and procedures used for Ancillary Equipment for equipment maintenance shall be those prescribed by DA PAM 738-750, The Army Maintenance Management System (TAMMS). Maintenance forms and records used by Marine Corps personnel are prescribed by TM 4700-15/1.

REPORTING EQUIPMENT IMPROVEMENT RECOMMENDATIONS (EIR)

If your equipment needs improvement, let us know. Send us an EIR. You, the user, are the only one who can tell us what you don't like about your equipment. Let us know why you don't like the design or performance. Put it on a SF 368 (Product Quality Deficiency Report). Mail it to Commander, U.S. Army Tank-automotive and Armament Command, ATTN: AMSTA-LC-R, Kansas Street, Natick, MA 01760-5052. We will send you a reply.

Navy submit NAVSEA Form 4160/1 (Rev 2-99) to:

Commander, NSDSA Code 5E30, NAVSURFCENDIV
4363 Missile Way, Port Hueneme, CA 93043-4307.

A reply will be sent directly to you.

CORROSION PREVENTION AND CONTROL

Corrosion Prevention and Control (CPC) of U.S. Army materiel is a continuing concern. It is important that any corrosion problems with the Ancillary Equipment for Personnel Troop Parachute System be reported so that the problem can be corrected and improvements made to prevent the problem in future items. While corrosion is typically associated with rusting of metals, it can also include deterioration of other materials, such as rubber and plastic. Unusual cracking, softening, swelling or breaking of these materials may be considered a corrosion problem. If a corrosion problem is identified, it can be reported using a Standard Form 368 Product Quality Deficiency Report. Using key words such as "corrosion," "rust," "deterioration," or "cracking" will assure that the information is identified as a CPC problem. This form should be submitted to the address specified in DA PAM 738-750, Functional Users Manual for the Army Maintenance Management System (TAMMS).

DESTRUCTION OR ARMY MATERIEL TO PREVENT ENEMY USE**GENERAL INFORMATION:**

Objective. Methods of destruction used to inflict damage on air delivery equipment should make it impossible to restore equipment to a usable-condition in a combat zone, by either repair or cannibalization.

Authority. Destruction of air delivery equipment that is in imminent danger of capture by an enemy is a command decision that must be made by a battalion or higher command, or the equivalent.

Implementation plan. All units that possess air delivery equipment should have a plan for the implementation of destruction procedures.

Training. All personnel who use or perform such functions as rigging, packing, maintenance, or storage of air delivery equipment, should receive through training on air delivery equipment destruction procedures and methods. The destruction methods demonstrated during training should be simulated. Upon completion of training, all applicable personnel should be thoroughly familiar with air delivery equipment destruction methods and be capable of performing destruction without immediate reference to any publication.

SPECIFIC METHODS:

Specific methods of destroying Army material to prevent enemy use shall be by mechanical means, fire or by use of natural surroundings.

Destruction by Mechanical Means. Air delivery equipment metal assemblies, parts, and packing aids shall be destroyed using hammers, bolt cutters, files, hacksaws, drills, screwdrivers, crowbars, or other similar devices used to smash, break, bend or cut.

**WARNING**

Exercise extreme care when using petroleum products to destroy equipment by fire, as these materials are highly flammable. Improper handling may cause injury to personnel.

Destruction by Fire. Items that can be destroyed by fire shall be burned. The destruction of equipment by use of fire is an effective method of destroying low-melting-point metal items (e.g., side rails, threaded portions of nuts and bolts, and platforms). However mechanical destruction should be completed first, whenever possible, before initiating destruction by fire. When items to be destroyed are made of metal, textile materials (or some comparable low combustible material) should be packed under and around the items, then soaked with a flammable petroleum product and ignited. Proper concentration of equipment that is suitable for burning will provide a hotter and more destructive fire.

Destruction by Use of Natural Surroundings. Small vital parts of assemblies, that are easily accessible, may be disposed of as follows: disposal or denial of equipment to an enemy may be accomplished through the use of natural surroundings. Accessible vital parts of assemblies may be removed and scattered through dense foliage, buried in dirt or sand, or thrown into a lake, stream, or other body of water. Total submersion of equipment in a body of water will provide water damage as well as concealment. Salt water will inflict extensive damage to air delivery equipment.

PREPARATION FOR STORAGE AND SHIPMENT

For storage and shipment, refer to TM 10-1670-201-23/T.O. 13C-1-41/NAVAIR 13-1-17, WP 0030 00 and WP 0031 00 of this manual.

WARRANTY INFORMATION

Ancillary Equipment for Personnel Troop Parachute System do not contain warranty provisions except for the Parachute Drop Bag (PDB) which is warranted as follows:

Eagle Industries warranties the PDB for 5 years or 125 jumps on material and workmanship from the time the PDB is first used. Shelf life will be for a period of 5 years. Eagle industries will pay two way shipping cost if the PDB is found to have faulty material or workmanship. All other freight expense related to repairs is the customer’s responsibility. Eagle’s PDB is designed to meet or exceed the specifications called out in Natick’s bid contract. If the PDB is abused or neglected by the government in normal use, the warranty may or may not apply. This will be at Eagle Industries discretion, and a written report will be provided to Natick for evaluation and rebuttal. If PDB is found to have problems in material and workmanship, Eagle Industries will repair the PDB at no charge. It is Eagle Industries full intent to provide Natick with the highest quality, both in material and workmanship, and the safest PDB possible. Eagle has, and always will stand behind it’s workmanship and materials used.

OFFICIAL NOMENCLATURE AND CROSS REFERENCE

The following lists cross-reference, common names used throughout this manual to official nomenclature.

COMMON NAME	OFFICIAL NOMENCLATURE
Extension	Extension, Static Line
Backstrap	Backstrap, Harness
Dragon Pack	Jump Pack, Dragon Missile
Weapons Case	Case, Parachutist’s, Individual Weapon, M-1950
Line	Line, Lowering
Harness	Harness, Single Point Release
AT4-JP	Pack, Assembly, AT4
Stinger Pack	Jump Pack, Stinger Missile
SCUBA Set	Accessory Set, SCUBA
Drop Bag	Drop Bag, Parachute

LIST OF ABBREVIATIONS/ACRONYMS

BER	Beyond Economic Repair	MTG	Mounting
BOI	Basis of Issue	MWO	Modification Work Order
CAGEC	Commercial and Government Entity Code	NF	National Fine (Thread)
Cm.	Centimeter	Ni-Cad	Nickel Cadmium
CPC	Corrosion Prevention and Control	NIIN	National Item Identification Number
DA	Department of the Army	No.	Number
DS	Direct Support	NBC	Nuclear, Biological and Chemical
Dtd.	Dated	NSN	National Stock Number
EA	Each	OD	Olive Drab
EIR	Equipment Improvement Recommendation	oz.	Ounces
EDS	Electrostatic Discharge Sensitive	PMCS	Preventive Maintenance Checks and Services
ESC	Equipment Serviceability Criteria	PDQR	Product Quality Deficiency Report
°F	Fahrenheit	psi.	Pounds per square inch
FSCM	Federal Supply Code for Manufacturer	RPSTL	Repair Parts and Special Tools List
FSC	Federal Supply Classification	SMR	Source, Maintenance and Recoverability
ft.	Feet	TAMMS	The Army Maintenance Management System
in.	Inches	TB	Technical Bulletin
Ltrs.	Liters	TMDE	Test Measurement and Diagnostic Equipment
LG	Long	U/M	Unit of Measure
Lbs	Pounds	UOC	Usable on Code
MAC	Maintenance Allocation Chart	WP	Work Package
MTOE	Modified Table of Organization and Equipment		

SAFETY, CARE AND HANDLING

The following subparagraphs summarize the safety, care and handling requirements for Ancillary Equipment for Personnel Troop Parachute Systems.

Safety. Use care in handling Ancillary Equipment for Personnel Troop Parachute System as exposed metal parts could cause painful injuries.

Care and Handling. Every effort shall be made to protect the equipment from weather elements, dust, dirt, oil, grease, and acid. When available, an environmentally controlled building should be used to store Ancillary Equipment for Personnel Troop Parachute Systems. Equipment shall be stored in a dry, well-ventilated location and protected from pilferage, dampness, fire, dirt, insects, rodents, and direct sunlight.

COMMON TOOLS AND EQUIPMENT

For authorized common tools and equipment, refer to the Modified Table of Organization and Equipment (MTOE) applicable to your unit.

SPECIAL TOOLS, TEST EQUIPMENT AND DIAGNOSTIC EQUIPMENT (TMDE), AND SUPPORT EQUIPMENT

Special tools, TMDE and support equipment are not required.

REPAIR PARTS AND SPECIAL TOOLS LIST (RPSTL)

Repair parts are listed and illustrated in WP 0035 00 through WP 0049 00 of this manual.

WARNINGS, CAUTIONS AND NOTES

Be alert and note **WARNINGS**, **CAUTIONS**, and **NOTES**. These provide for safe operation of the equipment, and protect you and your equipment from injury and damage.

END OF WORK PACKAGE

TM 10-1670-299-20&P

CHAPTER 1

**DESCRIPTION
AND
THEORY OF OPERATION**

**ANCILLARY EQUIPMENT FOR:
PERSONNEL TROOP PARACHUTE SYSTEM**

UNIT MAINTENANCE
ANCILLARY EQUIPMENT FOR PERSONNEL TROOP PARACHUTE SYSTEM
EQUIPMENT DESCRIPTION AND DATA

Equipment Characteristics, Capabilities, and Features. The ancillary equipment components of the Personnel Troop Parachute System are designed to facilitate the adaptation of various types of personal equipment and weapons to the individual parachute. Their use is dictated by the nature and equipment requirements of each particular mission. There are no unique maintenance related requirements or characteristics. Ancillary equipment components are constructed of various types of fabric materials and require only the kind of maintenance normally associated with personal equipment items.

Location and description of major components. Equipment location information shall be prepared including external and internal views of the equipment used to show general features and all major components. This information shall not duplicate information contained in the equipment data requirements and the equipment characteristics, capabilities, and features.

Extension, Static Line, Standard, 5-Foot (1). The static line extension (1) is constructed of Type VIII nylon. It comes with a permanently attached cover that is placed over the snap hook connection when the extension is used with the standard 15-foot static line. The extension is 5 feet long. The cover is constructed of two strands of nylon cord, separated by a strip of pressed felt material, enclosed in a cotton duck fabric sleeve. The extension has a snap hook on one end and an attaching ring on the other.

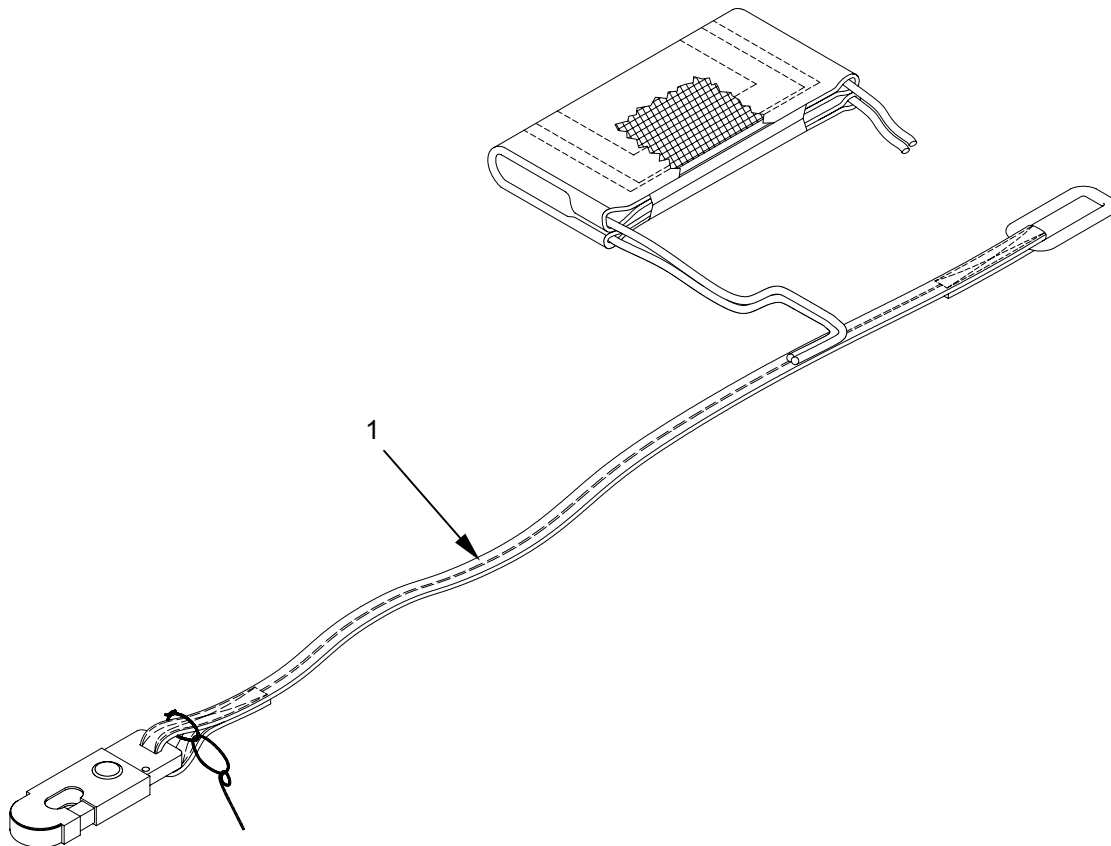

EXTENSION, STATIC LINE

Accessory Set, SCUBA (2).

1. **Support Strap (3).** Two support straps (3) are used with the SCUBA set. They are constructed of Type III Nylon Webbing with a quick fit adapter at one end and approximately 66-inches long.
2. **Backstrap, Harness (4).** The backstrap harness (4) is approximately 96-inches long and constructed of Type XIII Nylon Webbing.
3. **Strap, Waistband Extension (5).** The waistband extension strap (5) is constructed of Type VIII Nylon Webbing that is enclosed in Type III Nylon Duck Cloth. The Strap is 24.5-inches long, with one end is rounded, and an adjuster attached to the other end. Type III Nylon Tape is sewn to one side of the strap.
4. **Shield (6).** The shield is a U-shaped metal plate (6) installed over the SCUBA tank regulators to prevent the static line from becoming entangled in the regulator valves.

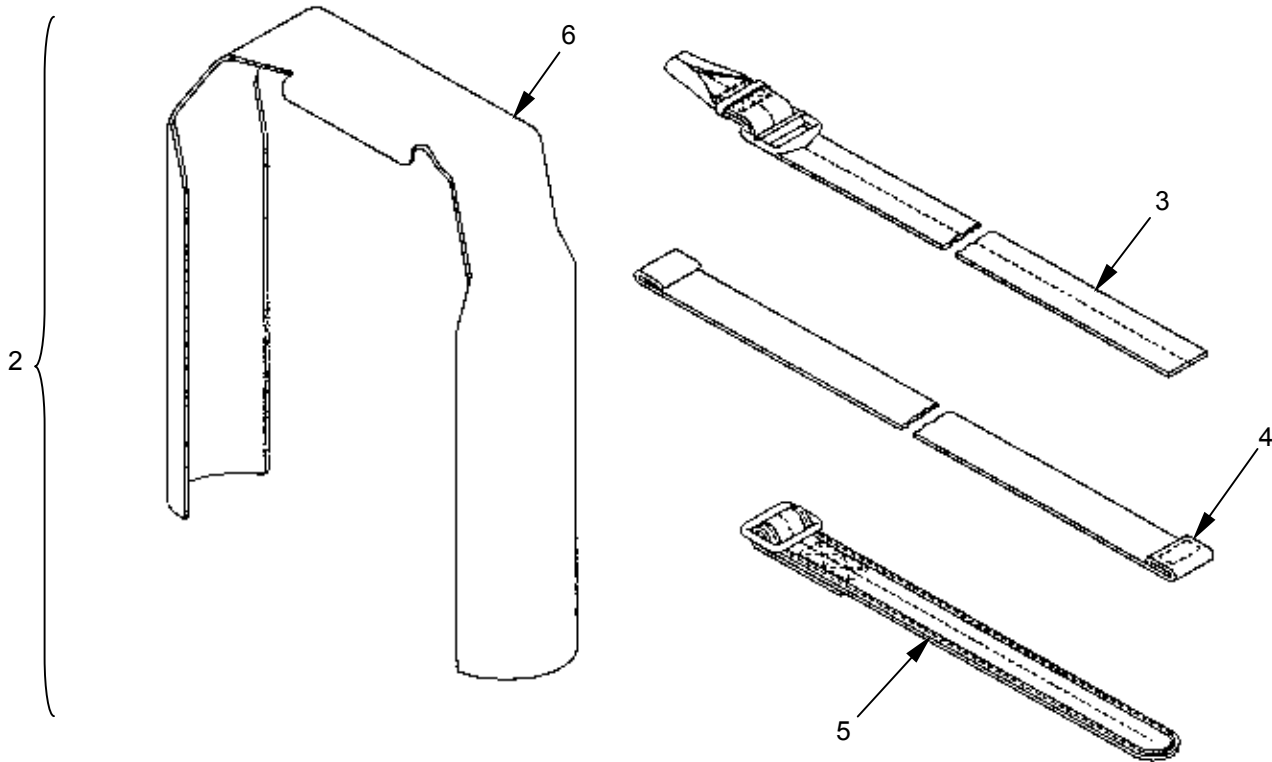

ACCESSORY SET, SCUBA

Line, Lowering 15-Foot (7). The lowering line (7) is constructed of nylon webbing with a snap hook at one end. An extension extractor fabricated of nylon duck material is located at the center. The adapter web has attaching hardware on one end.

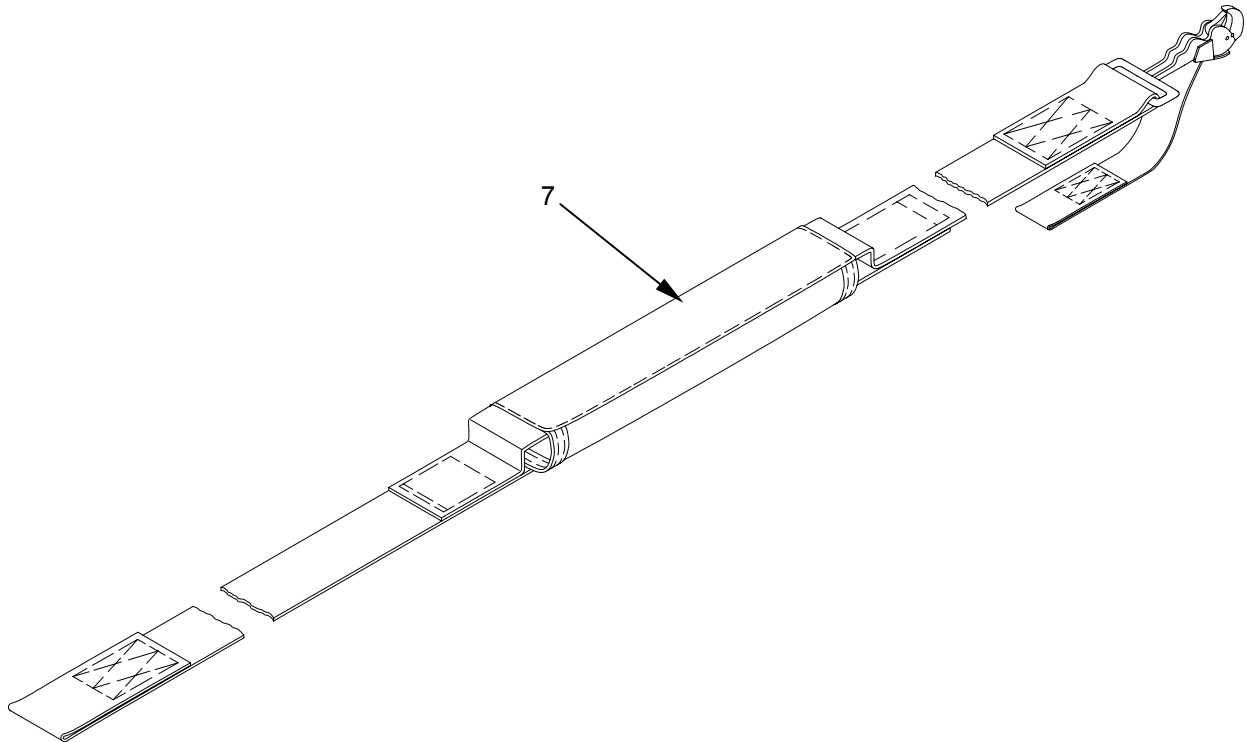

LINE, LOWERING

Jump Pack, Dragon Missile (8). The dragon pack (8) is fabricated from nylon or cotton duck, webbing and various types of tapes. The pack incorporates adjustable straps with quick fit and release hardware listed in WP 0039 00. A 15-foot lowering line and stowage pocket is attached to the exterior of the pack.

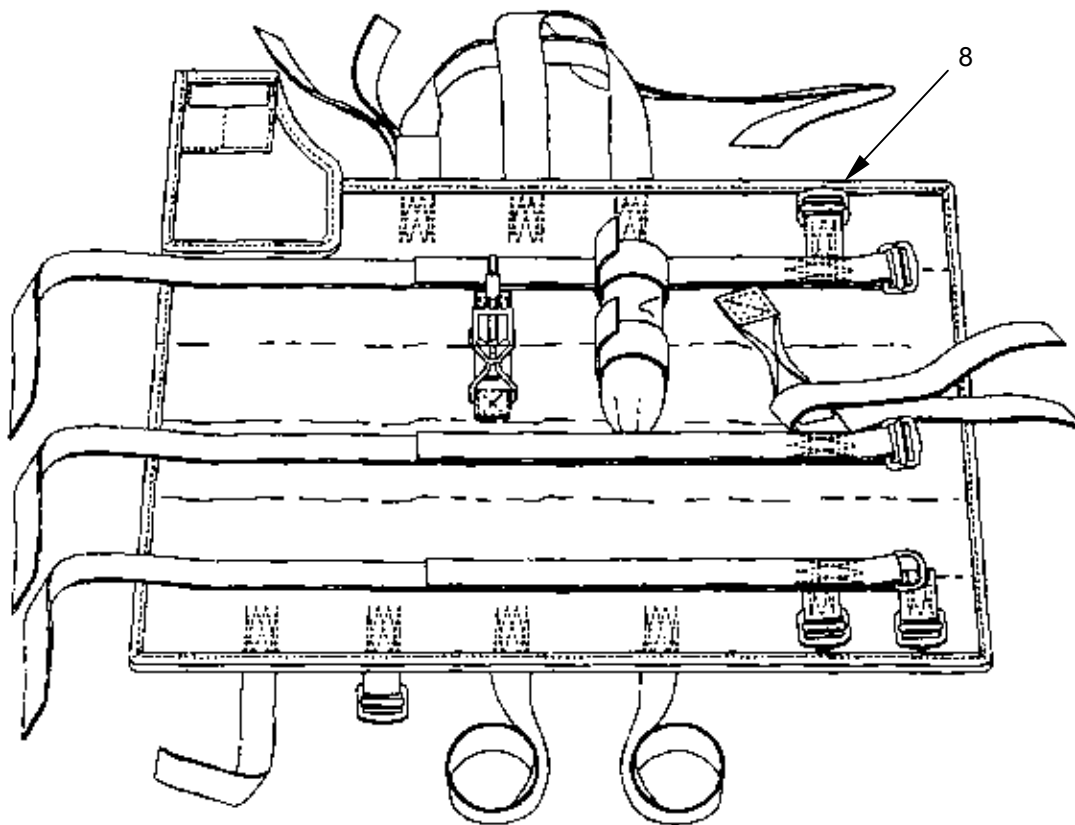

JUMP PACK, DRAGON MISSILE

Harness, Single Point Release (9).

1. **Strap, Leg Release (10).** This strap is constructed of 1-inch wide nylon elastic webbing, approximately 4-inches long with a side release buckle (female) at one end and a Type III Spur Grommet on the other.
2. **Handle, Release (11).** The single point release handle assembly consists of a tubular webbing lanyard to which the angular wire release cable is attached.
3. **Strap, Harness, Attaching (12).** This strap is made of 1 ½ -inch Type III nylon webbing with a snap hook on one end, and a triangular link on the other.

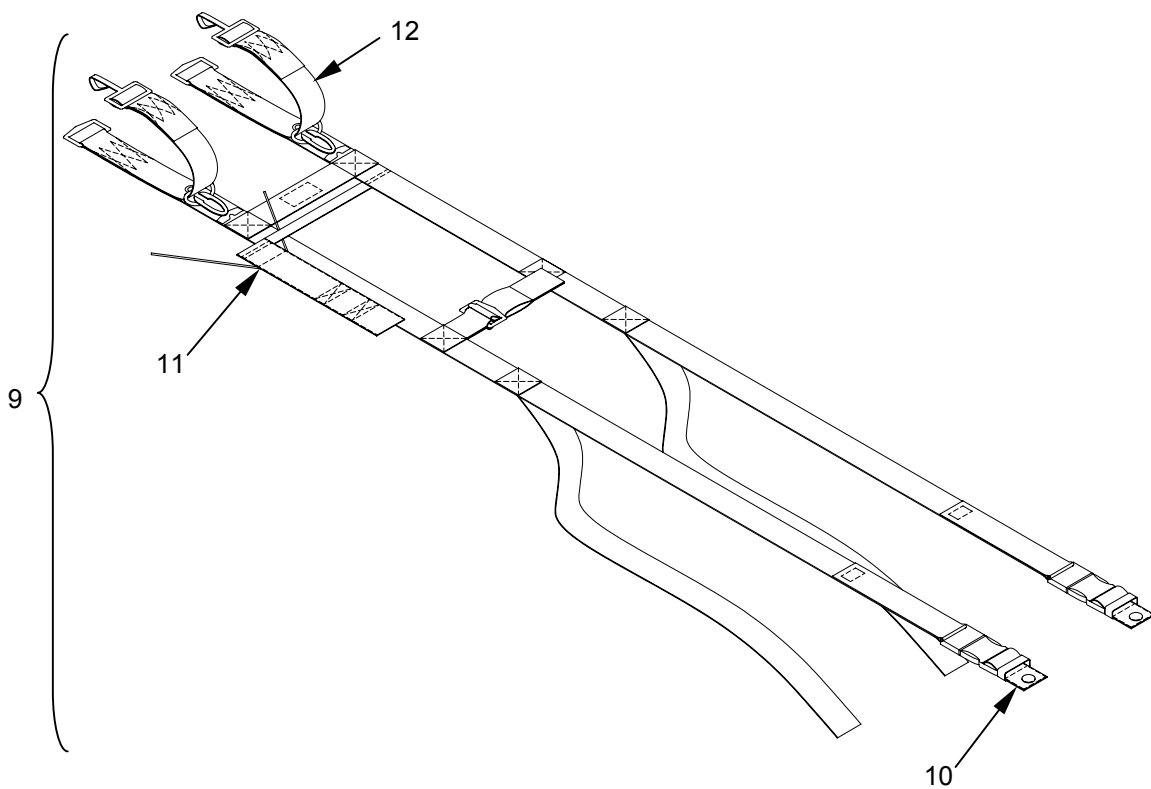

HARNESS, SINGLE POINT RELEASE

Pack, Assembly, AT4 (13). This jump pack is fabricated from nylon duck, nylon webbing, wool felt, and cotton tape. The pack incorporates adjustable straps and quick release/fit hardware listed in WP 0041 00. A 15-foot lowering line and stowage pocket is located on the exterior of the pack.

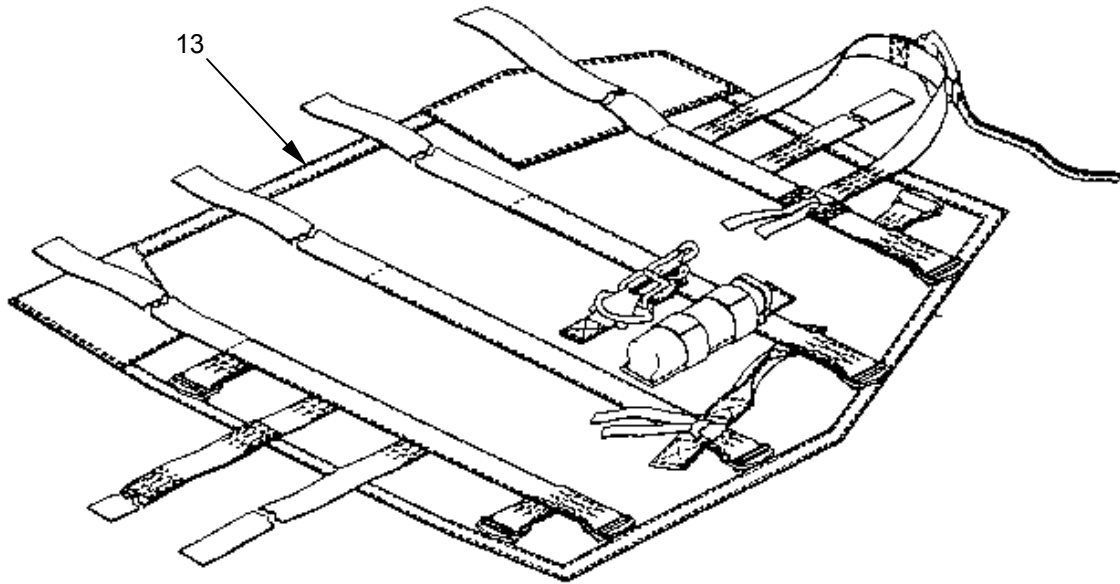

PACK, ASSEMBLY AT4

Case, Parachutist's Individual Weapon, M-1950 (Cotton) (14)/ Case, Parachutist's Individual Weapon, M-1950 (Nylon) (15). The parachutist's individual weapons case is made of Type I cotton duck lined with ¼-inch thick felt or cloth, nylon 12.5 oz lined in ¼-inch thick felt. The bottom of the case is reinforced on the inside with leather or inner reinforcement webbing. The case is closed at the side by means of a slide fastener thong and a snap fastener. The weapons case is equipped with a quick-release snap link and several metal loops that are all attached to the case by webbing chapes. The snap link is provided for accommodation of the quick-release snap-hook that secures the weapons case to the parachutist's harness. The weapons case also has a webbing-adjusting strap; two tiedown tapes, each of which is attached to a webbing tie-down loop; a 15-foot lowering line; and a lowering line pocket. Hardware items are listed in WP 0042 00 for Case, Parachutist's Individual Weapon, M-1950 (Cotton) and WP 0043 00 for Case, Parachutist's Individual Weapon, M-1950 (Nylon).

NOTE

The Cotton M-1950 is no longer supported.

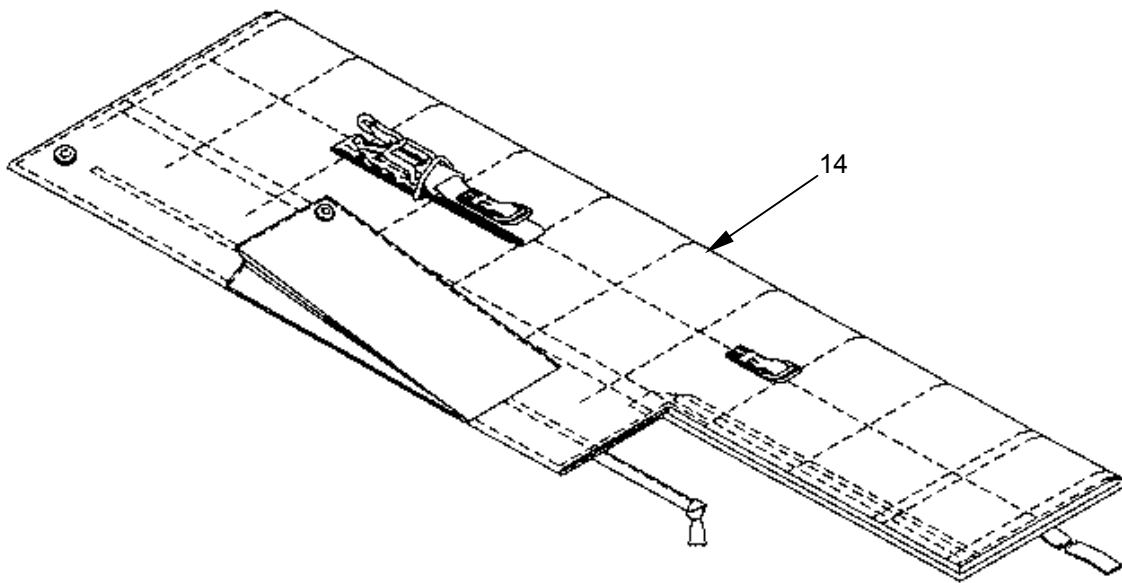

CASE, PARACHUTIST'S INDIVIDUAL WEAPON, M1950 (COTTON)

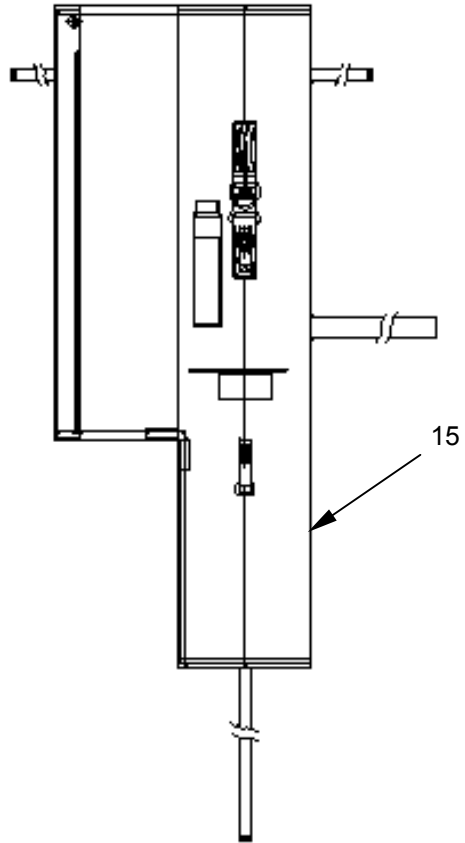

CASE, PARACHUTIST'S INDIVIDUAL WEAPON, M1950 (NYLON)

Case, Parachutist's Weapon and Individual Equipment (16). This equipment consists of a pack and a harness. The hexagonal-shaped pack is constructed of Type I cotton duck. The body is lined with ¼-inch felt, and a network of Type VIII cotton-nylon webbing suspender and securing straps. The straps are reinforced and are equipped with quick-fit reversible adapters of 750-pound breaking strength. The pack is folded at the top and each side is held to the top by a rivet. The harness consists of a Type I cotton duck body and flap, a network of securing and suspension straps made of Type VIII nylon webbing, appropriate items of hardware, and a push pull actuator assembly. The release assembly comprises the push-pull actuator assembly with release knob, a keeper pin with a Type IV nylon webbing strap, a left and right-hand fastener and a Type X nylon webbing quick-release strap equipped with a snaphook at one end and a quick-release, quick-fit connecting link at the other end.

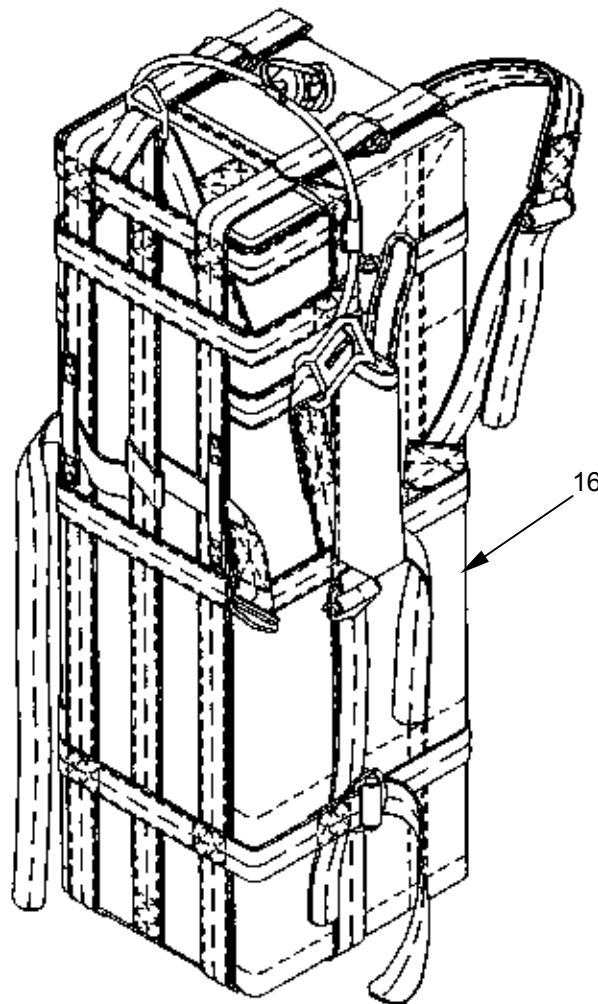

CASE, PARACHUTIST'S WEAPON AND INDIVIDUAL EQUIPMENT

Jump Pack, Stinger Missile (17). The stinger pack consists of a nylon shell and felt liner. The pack incorporates adjustable straps of Type II, VII, and X woven nylon webbing with quick fit and release hardware, a carrying handle, and a single-pull quick release subsystem. Hook and pile fasteners of varying dimensions are also used. The standard 15-foot lowering line is used with this pack. Hardware items are listed in WP 0045 00.

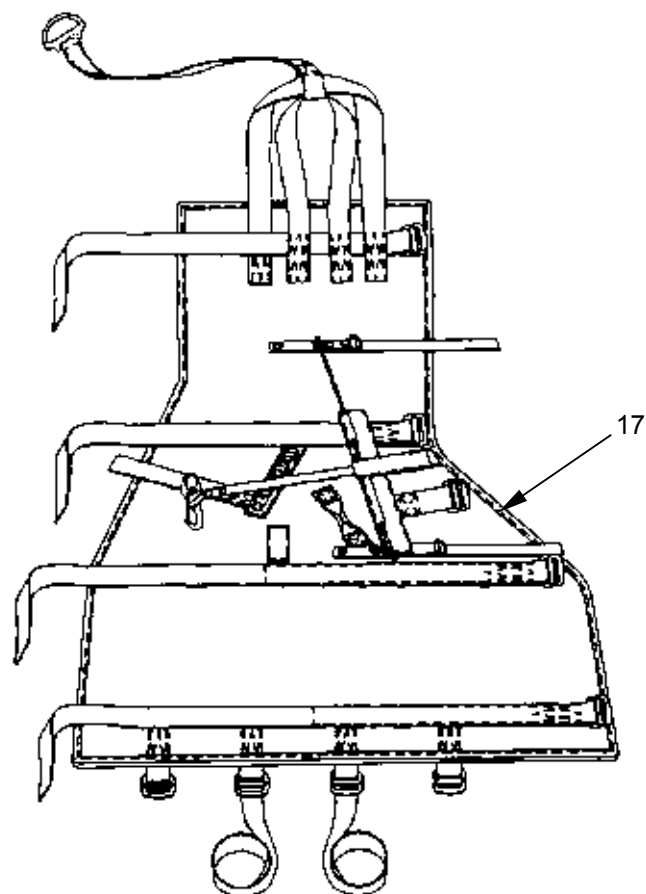

JUMP PACK, STINGER MISSILE

Parachutist's Individual Equipment Rapid Release PIER2 (18). The release assembly consists of a webbing and hardware release assembly that connects the side mount (weapons container) to the large D-ring on the harness and the front mount (rigged rucksack). Pulling the single point release handle on the front mount allows the containers to be released simultaneously as a system; the front mount separates from the jumper which activates the PIE/R2 and releases the side mount on the standard 15-foot lowering line.

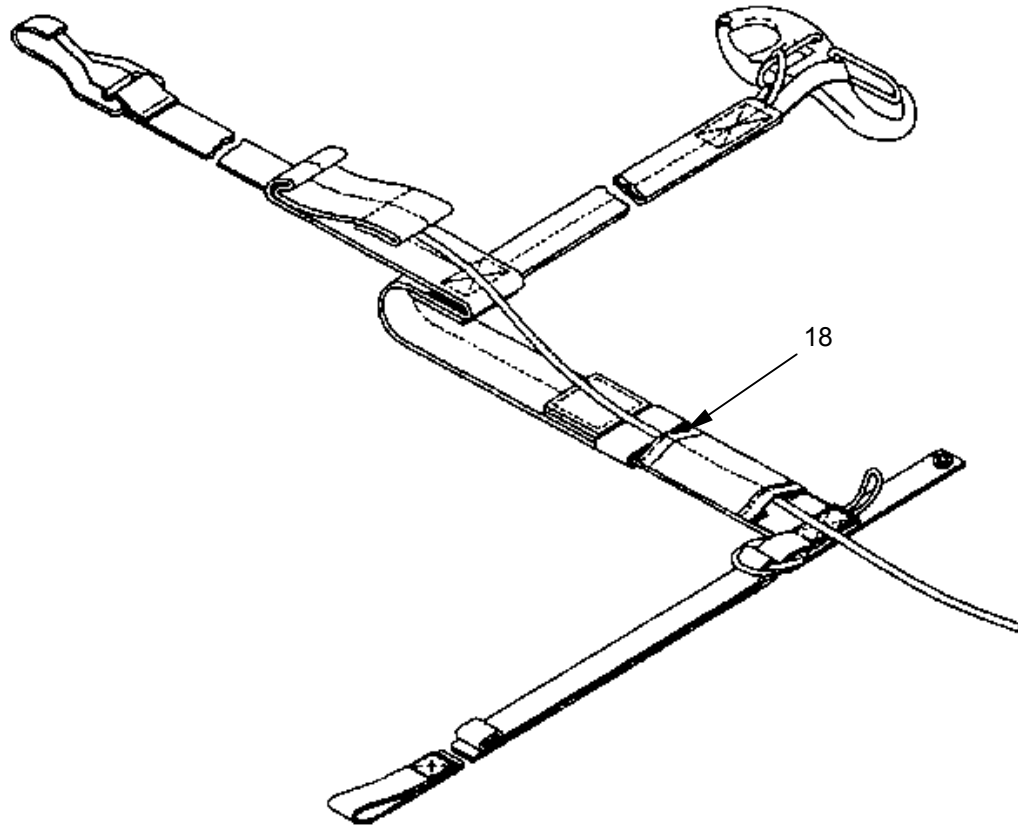

RAPID RELEASE ASSEMBLY

Container, Front Mount (AIRPAC) (19). The front mount container allows for a single point release and provides a bag for parachute recovery.

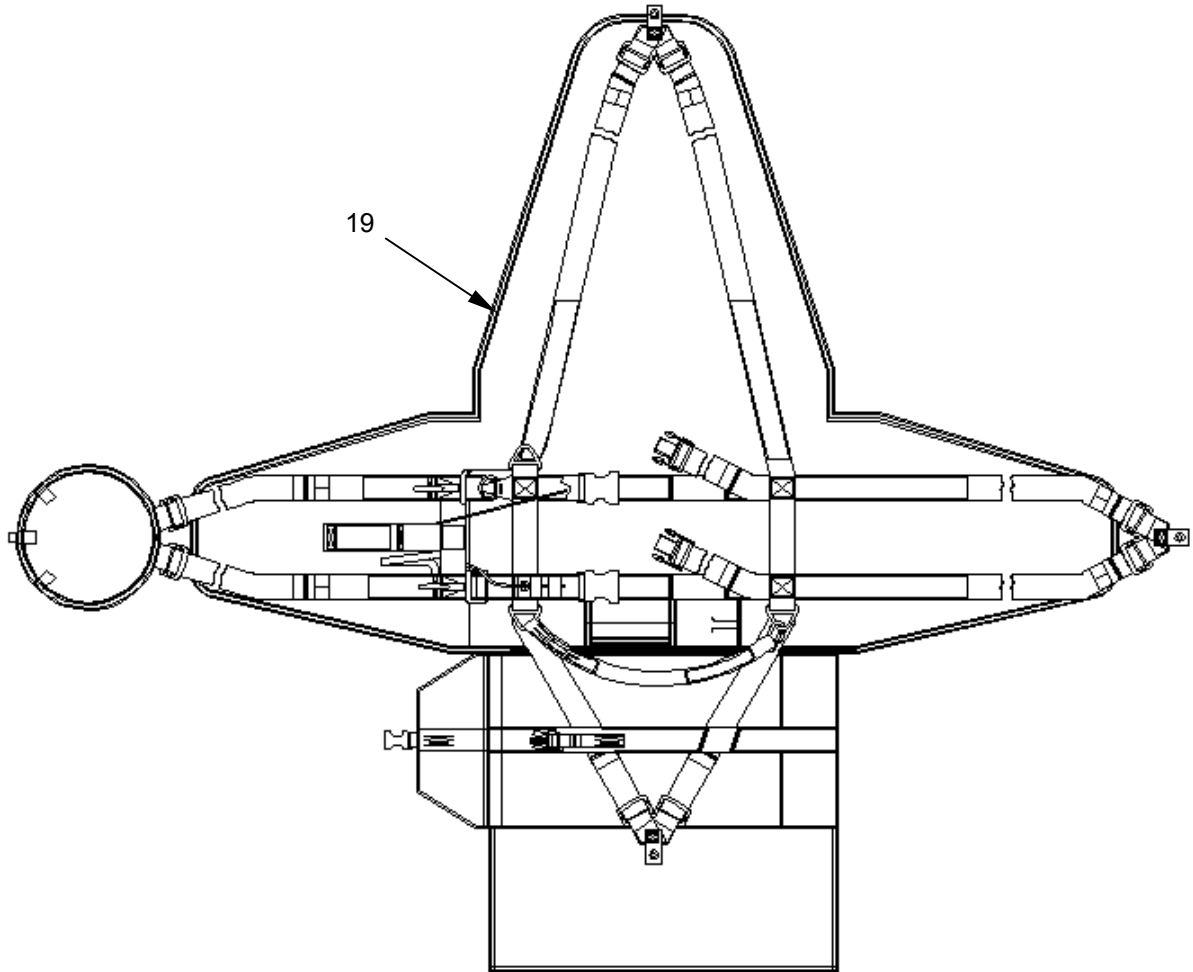

CONTAINER, FRONT MOUNT (AIRPAC)

Container, Side Mount (AIRPAC) (20). The side mount container is designed for large weapons and equipment such as the Dragon Missile, AT4 missile and snow/ice traversing equipment.

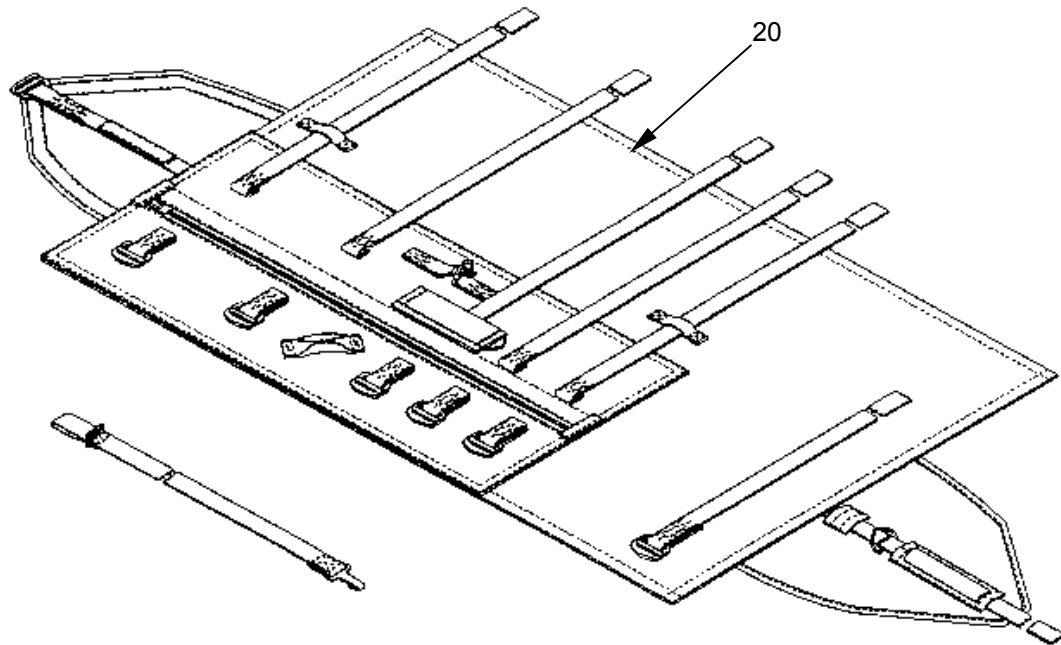

CONTAINER, SIDE MOUNT (AIRPAC)

Parachute Drop Bag (PDB) Description. (21) The Parachute Drop Bag is a fast, easy and secure way of carrying the jumper's rucksack and Load Bearing Equipment during Military Free Fall or Static Line deployment operations. The PDB is made from textured nylon, cloth duck material. The PDB has shoulder straps on both inside and outside the bag. It will be a Woodland or Desert camouflage on the outside with the inside being a darker gray color so it will have a lower profile when transporting through airports and high secure areas. An integrated lowering line (7-ft or 15-ft) is used for lowering of equipment during Military Free-Fall and Static Line operations. The PDB has dual mounting capabilities that will allow the jumper to attach the bag to the front for Static Line operations, and rear or front configurations for Military Free-Fall operations. Incorporated in the PDB is a single point release system, which will allow for the jumper to lower their equipment easily while descending to the drop zone. Parachute grade hardware is used on this system for safety and durability. The PDB comes in a regular size which will be incorporated into jump operations whether MFF or Static Line. The regular PDB weighs 7 lbs and has approx. 5520 cubic inches of storage space with a minimum 35 lbs and maximum 120 lbs rigged for jump operations.

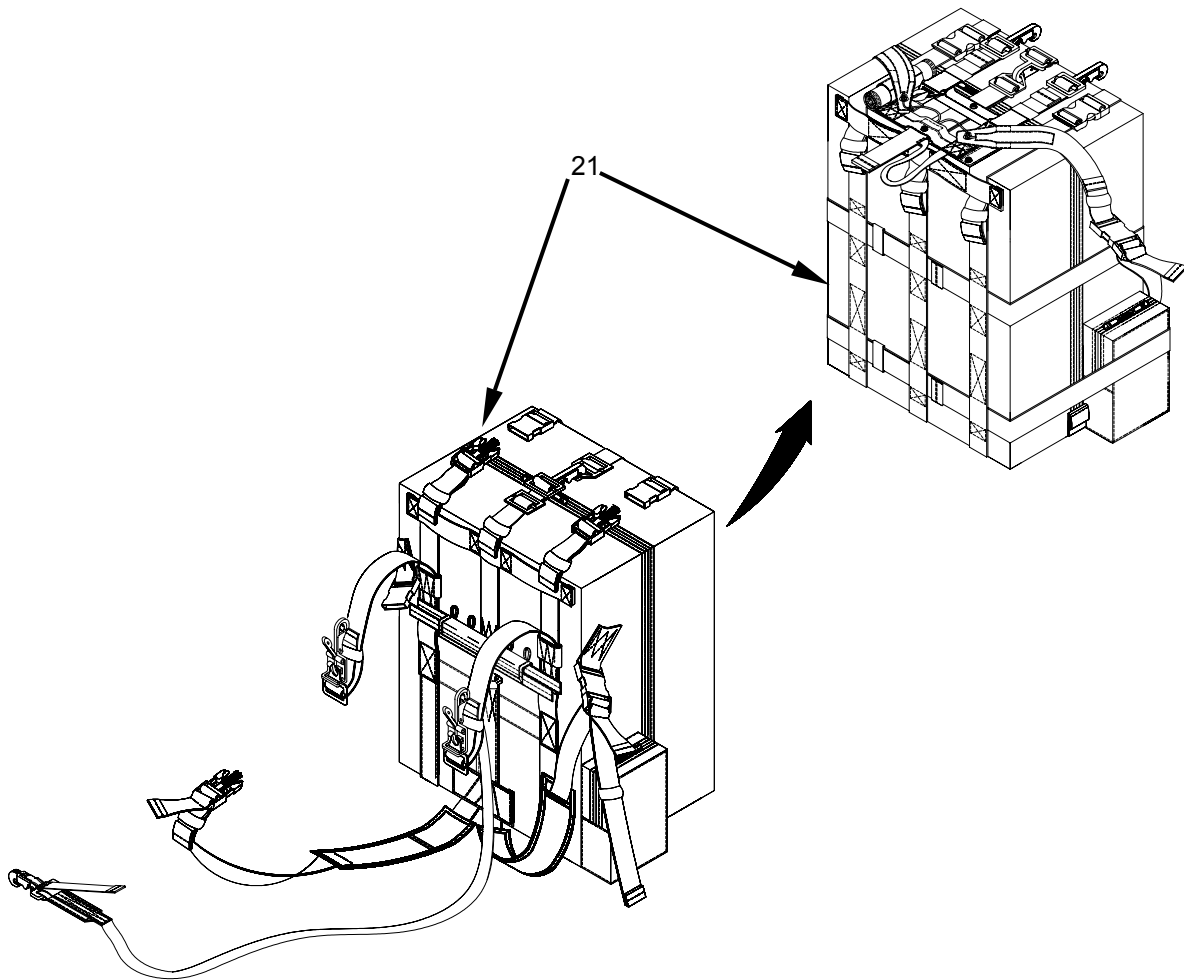

DROP BAG, PARACHUTE (PDB)

EQUIPMENT DATA

The following technical and identification data pertains to the Ancillary Equipment For: Personnel Troop Parachute System.

Equipment Specification Data**Table 1-1 Equipment Data**

Item	Material	Finished Dimension
Extension Static Line, Standard, 5-Foot	Type VIII Nylon Webbing	60" L
Support Strap	Type III Nylon Webbing	66" L
Backstrap Harness	Type XIII Nylon Webbing	69" L
Strap Waist-Band Extension	Type VIII Nylon Webbing	24.5" L
Shield	Aluminum	
Line, Lowering	Nylon	15-Feet
Jump Pack, Dragon Missile	Cotton or Nylon Duck	39" L 30" W
Harness Single Point Release	Type VIII Nylon Webbing	
Strap, Leg Release	Cotton Webbing	4" L
Handle, Release	Nylon Webbing	
Strap, Harness Attaching	Type III Nylon Webbing	
Pack, Assembly AT4	Nylon or Cotton Duck	40" L 30" W
Case, Parachutist's Individual Weapon M1950 (Cotton)	Cotton Duck	33.5" L to 50.5" L 10" W
Case, Parachutist's Individual Weapon M1950 (Nylon)	Nylon Duck	34" L to 51" L 10 1/4" W
Case, Parachutist's Weapon/Individual Equipment	Cotton Duck	36" L, 12" W, 12" D Adjustable to 18" L, 12" W, 6" D
Jump Pack Stinger Missile	Nylon Duck	67" L 38" W
AIRPAC, Release, Front & Side Mount	N/A	N/A
Drop Bag, Parachute	Cloth, duck, textured nylon, Class III, CG483	30" H, 26" W, 18" D

Table 1-2 Equipment Data for Parachutist's Drop Bag (PBD)

Item	Material	Specification
PDB-Body	Cloth, duck	Cloth, Duck, Textured Nylon, Class III MIL-C-43734
PDB-Body	Nylon Thread	Anefil Nylon. Tex 70, 453G, BT-69E, V-T-295-MIL-T-7807, Tensile Strength 8.5 lbs. Size-5 Cord. Tensile Strength 40lbs.
PDB-Harness seatbelt, Lt. 2"	Nylon Webbing	MIL-W-4088-T4,T8,T12,T13, MIL-W-4088-2/2 HB Twill. Type 24
PDB/SPR	Nylon Tubular	MIL-W-5625, 1/4" Black
Keepers	Cotton Elastic	MIL-W-5664, Class 1.1"
PDB/SPR Cover (Snaps)	Lift-the-Dot	MS-27983, Style 2, Durable-Dot, Black
PDB/SPR Cover (Grommets)	Grommets	Spur-Type Grommets & Washer. Stainless Steel. SS-OL 1/4"
PDB/SPR (Soft Loops)	Nylon Parachute Cord	Type III Nylon Cord. 550 lbs. Red/White
PDB/SPR	Nylon Webbing Type IV	7603-3" Nylon part #8962-MIL-W-4080 Type IV
Main Body	Nylon Tape	MIL-W-5038, T3
Snap	Center Vertical Strap	MS-22-43 or 48B707. 2500#
"V" Quick Fit	Center Vertical Strap	MS-70113-1-2
Quick Release Adaptor	Center Vertical Strap	MS-44A-9360
SR Male Trovato 2" SR Female	Outside Vertical Strap	Plastic Buckles. Engineering Closures & Components 5614/Set
SR Female Trovato 2"	Outside Unattached Cross Strap	Plastic Buckles, Engineering Closures & Components
Triangle Ring	Harness to Connector Strap 1	MIL-22020-2, 2500#
Accessory Attaching Ring	Lowering Line Attach	MIL-701223-2
Reversible Quick-Fit Adapter	Inside Shoulder Strap	MIL-70101-2, 500#
Quick-Fit Release Adapter	Outside Shoulder Strap	MIL-22040-2, 2500#
Adapter	Hook-up Webbing Buckle	MS-11-1-183, 2500#
Quick Release Snap	Hardware Quick Release	MIL-70079-1, 2500#
Ejector Snap	Lowering Line	MIL-22017-1, 2500#
A.L.M. 1/8"	Shoulder Straps Pad	Foam EVA 1/8"
YKK	Zippers for Main Body & Utility Pockets	U-F-106
Hook & Pile (Velcro)		MIL-F-21840

COMMON TOOLS AND EQUIPMENT

For authorized common tools and equipment, refer to the Modified Table of Organization and Equipment (MTOE), CTA 50-970, or CTA 8-100, Army Medical Department Expendable/Durable Items, as applicable to your unit.

Repair parts are listed and illustrated in the repair parts and special tools list located in work packages 0035 00 through 0049 00.

END OF WORK PACKAGE

**OPERATOR, UNIT, AND DIRECT SUPPORT MAINTENANCE
ANCILLARY EQUIPMENT FOR PERSONNEL PARACHUTE SYSTEM
THEORY OF OPERATION**

THEORY OF OPERATION

Equipment Configuration. The Ancillary Equipment for Personnel Troop Parachute System is used with individual parachutes. This equipment is not provided or issued as a set; each component must be requisitioned separately. The equipment configuration is dictated by the mission.

Description. This paragraph will explain how the various components are used in conjunction with others to achieve the intended purpose. The interface and function of each component will be explained.

Extension, Static Line. The 5-foot long static line extension is used only with certain types of aircraft (C-46, C47, CH46, CH53). When used, it is attached to the normal standard 15-foot static line by placing the attaching ring of the extension into the snap hook of the standard static line. The safety pin is then inserted and bent. The extension cover is then placed over the snap hook and taped in place.

Accessory Set, SCUBA. This set includes a waistband extension, a backstrap harness, support straps, and a shield. The waistband extension is attached to the waistband adapter and allows for the extra bulk of the SCUBA gear. The longer (69-inch) backstrap harness replaces the standard 59-inch horizontal backstrap in this configuration. A support strap is attached to each of the canopy releases of the harness assembly. The shield is installed over the SCUBA tank to prevent the static line from becoming entangled in the regulator valves.

Lowering Line. The standard lowering line is used to lower a 15-foot long assembly with a quick ejector snap fastener for attachment to the parachute harness. The line can be used with any of the packs described in this manual.

Jump Pack, Dragon Missile. The Dragon Pack is designed to form a padded, wrap-around type packing around the missile for attachment to the parachutist's harness. It also protects the Parachutist's M-4 rifle. The pack is attached to the left reserve parachute "D" Ring of the harness with a quick release type snap. A leg tiedown strap assists in retaining the pack to the parachutist during exit and main parachute deployment. The lowering line permits lowering the pack below the parachutist prior to landing to mitigate potential damage to personnel and weapons.

Harness, Single Point Release. This harness is a general-purpose item used by the individual parachutist to jump the ALICE medium or large combat pack with or without frame. It is of an "H" type design with a network of equipment retainer straps, cross straps, leg straps, leg strap release assembly, attaching harness strap, and single point release handle.

Pack Assembly, AT4. The AT4 pack is designed to form a padded, wrap-around type packing around the AT4 missile for attachment to the parachutist's harness. It also protects the parachutist's M-16 rifle. The pack is attached to the left "D" Ring of the harness with a quick release type snap. Tiedown straps are provided for attachment to the harness main lift web and left leg for retaining the pack to the parachutist during exit and main parachute deployment. The lowering line permits lowering the pack below the parachutist prior to landing to mitigate potential damage to personnel and weapons.

Case, Parachutist's, Individual Weapons, M-1950. The parachutist's individual weapons case is used by the parachutist to carry individual and crew served weapons. A quick release snap fastener secures the case to the parachutist's harness and two tapes, which are tied to the case and to the parachutist, keep the case from swaying when the parachute deploys.

Case, Parachutist's Weapons and Individual Equipment. This is a general-purpose item used by the parachutist to carry designated combat equipment. Adjustable carrying straps permit the container to be carried in the same manner as a field pack. When rigged for jumping, the pack is encased in the harness.

Jump Pack, Stinger Missile. The pack is designed to carry one Stinger Missile round and is attached to the left side of the parachutist's harness. Prior to landing the pack is vertically suspended beneath the parachutist with a standard lowering line. A foam cap protects the weapon during impact.

Parachutist's Individual Equipment Rapid Release. This release assembly is primarily intended for use with the AIRPAC containers described below, but is also compatible with all existing containers. It provides a universal release of equipment containers carried by the parachutist.

Container, Aerial Delivery, General Purpose, Individual Equipment. Together with the container described below, this item is part of a system designed to carry a variety of the soldier's weapons and equipment. This container is front mounted, and will accommodate a rucksack, ammunition, and other, smaller items. It is adjustable to conform to the items carried.

Container, Aerial Delivery, Weapons and Equipment, Adjustable. This side mounted general-purpose container is designed to accommodate larger and longer equipment items carried by the parachutist, such as individual weapons, anti-tank weapons, antennas, skies or other bulky items. Up to 40 lbs may be carried in this container.

Parachute Drop Bag (PDB). The PDB is a lightweight nylon bag used to carry mission essential equipment to include current field packs (Alice Pack, Mollie Pack, Spear Pack, and Field Pack w/internal Frame) during Static Line and Military Free-Fall (MFF) jumps. The PDB is mounted to the d-rings on the main harness assembly of the MC-4 parachute system. When the jumper wears the PDB in the front mounting configuration the incorporated single point release will only be used. Mounting the PDB in the rear-mounting configuration the 2-point quick releases will only be used. Leg Straps assist in retaining the PDB bag to the parachutist during exit and main parachute deployment. Lowering line permits lowering the pack below the parachutist prior to landing to mitigate potential damage to personnel and equipment.

Lowering Line. The 7-foot or 15-foot lowering line is used to lower the PDB with a quick ejector snap fastener for attachment to the parachute harness. The 7-ft line is used for MFF and the 15-ft line is used for static line jumps.

END OF WORK PACKAGE

TM 10-1670-299-20&P

**CHAPTER 2
UNIT MAINTENANCE
ANCILLARY EQUIPMENT FOR:
PERSONNEL TROOP PARACHUTE SYSTEM**

**UNIT MAINTENANCE
ANCILLARY EQUIPMENT FOR PERSONNEL PARACHUTE SYSTEM
SERVICE UPON RECEIPT**

INITIAL SETUP:**Tools**

Needle, Tacking (WP 0034 00, Table 2, Item 9)

Personnel Required

92R (10) Parachute Rigger

Materials/Parts

Tape, Lacing and Tying (WP 0052 00, Table 1, Item 38)

Equipment Condition

All equipment shall be serviceable and ready for use.

OVERVIEW

This chapter contains information necessary to maintain Ancillary Equipment for Personnel Parachute Systems, on the unit maintenance level, in accordance with the Maintenance Allocation Chart (MAC) for the equipment. It includes the following:

1. Procedures for processing new or used equipment upon receipt.
2. Assembly of components prior to use.
3. Preventive maintenance procedures to ensure continued serviceability of all components.
4. As required inspections and maintenance procedures performed prior to airing, cleaning and drying, and salt-water contamination tests.
5. Repair methods and repair, or replacement, procedures for all components of the assembly.

INITIAL RECEIPT

The following describes the procedures for processing parachutes upon initial receipt.

General Procedures for Ancillary Equipment For Personnel Parachute Systems. When air delivery equipment is initially procured from a supply source and issued to a using unit, the item(s) will be unpacked from the shipping container(s) and inspected by a qualified parachute rigger (MOS 92R). The inspection performed will be a technical/ rigger-type inspection and will be conducted as outlined in the Preventive Maintenance Checks and Services (PMCS) procedures. Upon completion of the inspection, the item(s) will be tagged as prescribed in DA PAM 738-751. Serviceable equipment may then be entered either into storage or into use in airdrop operations, as applicable. An unserviceable item will be held and reported, in accordance with DA PAM 738-750/ MCO 4855.10B.

Shipping Materials. Save the shipping cartons and crates for reuse when possible.

Inspection Personnel. Personnel other than parachute rigger personnel may assist in the unpacking process of initially received equipment, as directed by the local air delivery equipment maintenance officer. However, the maintenance officer will ensure the entire unpacking effort is conducted under the direct supervision of a qualified rigger (MOS 92R).

Configuration Condition. Acceptance of new equipment from the manufacturer is based upon inspections made of sample lots that have been randomly selected in accordance with military standards. It is incumbent upon the using activity personnel to bear this in mind whenever equipment is first placed in service. Changes will sometimes evolve from the original equipment design and sometimes contractors are authorized deviations in material and construction techniques. Air delivery equipment that has been in the field cannot be expected to meet exacting manufacturing specifications; however, the equipment should closely reflect desired design characteristics. Since repairs, modifications, and/or changes can alter or detract from the configuration originally desired, such equipment shall be airworthy, safe, of the desired configuration, and adequate for intended use.

Parachute Log Record. The Army Parachute Log Record, DA Form 3912, AFTO 391, and NAVWPNCEN or NAWCWPNS CL 13512/11 (Premeditated Parachute Record) are history-type maintenance documents that accompany some of the Ancillary Equipment through the period of service of the individual assembly. The log record provides a means of recording maintenance actions performed on equipment. Normally, a log record is initiated and attached to the item by a using unit. However, if the item is subjected to alteration or modification by a maintenance activity during the interim period from date of manufacture to receipt by a using unit, the log record will be prepared by the activity performing the maintenance function. Once initiated, a log record will be attached to, and contained in, an affixed parachute log/record/inspection data pocket (if applicable), until such time as the item is destroyed or rendered unfit for further use or repair.

Additionally, should an item that requires a log record, be transferred from one unit to another, the log record for the item will accompany the item in the transfer action. A prepared log record will not be removed or separated from an item except as directed by the local air delivery equipment maintenance activity officer.

A log record that is illegible, lost, damaged, soiled, or precludes further entries due to lack of space, will be replaced, as applicable, with a serviceable item from stock.

Installing Attaching Tie.

Install attaching tie as follows:

1. Cut a 30-inch length of tape, lacing and tying (super tack), and double the lacing length.
2. Pass the looped end, of the double laced length, around the centerfold of the log and form a slip loop on the outside, at the log record top.

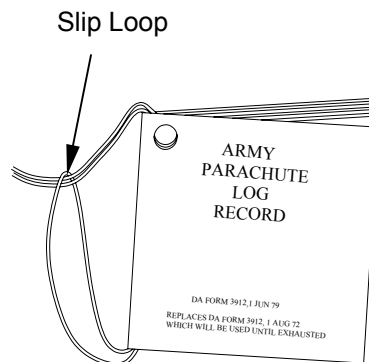

Forming Slip Loop on Log Record Outside

3. Pass the lacing length running ends through the corner attaching hole, from the front cover of the log record.

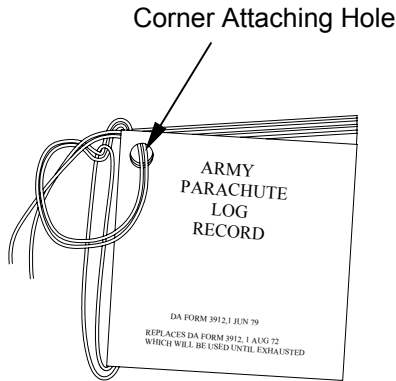

Passing Lacing Loose Ends Through Corner Attaching Hole

4. Ensure the running ends are routed over that part of the lacing length located along the log record centerfold.

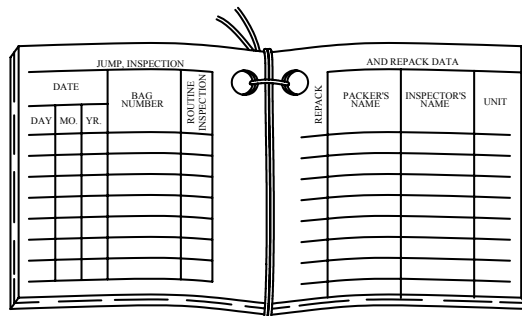

Routing Lacing Loose End Through Log Record Centerfold

5. Complete the attachment tie by making a half hitch on top of the slip loop made in 2., above.
6. Thread one running end of the log record attachment tie in a tacking needle and pass the tacking needle, with attached end, through the edge binding of the applicable parachute log record/ inspection data pocket.

- Remove the lacing end from the tacking needle; make a finished 10-inch-long log record attaching loop by securing the two lacing ends together with an overhand knot.

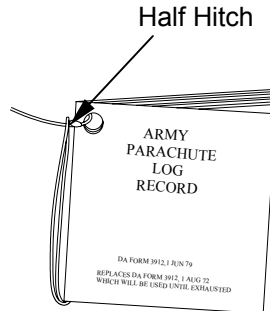

Log Record Attachment Tie Completed

- Insert the log record into the pocket (if applicable) and secure the record within the pocket using the pocket flap and applicable type flap fastener.

Accomplishing a Log Record. Upon completion of the first technical/ rigger-type inspection, the individual performing the inspection will initially prepare a log record for an item and accomplish subsequent record entries using the following procedures:

NOTE

Log record book entries will be made with a suitable type blue or black marking device that cannot be erased (no felt tip markers).

- Inside front cover.** Using the information provided on the item, make the following entries on the inside front cover of the log record. Entries may be contained on the inside of the back cover, if necessary.

SERIAL NO.	○
TYPE	
PART NO.	
DATE OF MFG. (Month & Year)	
MANUFACTURER	
CANOPY CONTRACT NO.	
MO/YR CANOPY PLACED IN SERVICE	
STATION & UNIT	

(Continued on inside back cover)

NOTE

A serial number is recorded in a log record as a method of establishing control for maintenance, Equipment Improvement Report (EIR) and Product Quality Deficiency Report (PDQR) documentation, and to ensure the correct original record is reattached should the record become detached. A serial number will not be used for property accountability, except in test projects or other special instances.

- a. Serial Number. Enter the item serial number.
- b. Type. Enter the item type.
- c. Part number. Enter the item part number (if applicable).
- d. Date of Manufacture. Enter the month and year the item was manufactured.
- e. Manufacturer. Enter the name of the item manufacturer.
- f. Contract Number. Enter the entire contract number specified for the item.
- g. Station and Unit. Enter the name of the station and unit to which the item is currently assigned. When an item is transferred permanently to another station, and/or unit, the original entry will be lined out and the name of the receiving station, and/or unit, will be entered.

2. **Inside Back Cover.** Entries may be continued on the inside back cover, if necessary.

STATION & UNIT (Continued)

3. **Modification Work Order (MWO) Compliance Record Page.** When a modification is performed on an item, the following entries will be made on the Modification Work Order Compliance Record pages of the log record, as follows:

- a. MWO Number. Enter the publication number and date of the MWO that describes the MWO (1, illustration below).

MODIFICATION WORK ORDER		COMPLIANCE RECORD					
MWO NUMBER	MWO TITLE	MODIFIED BY (NAME)	INSP. BY	UNIT	DATE		
					DAY	MONTH	YEAR
10-1670-243-23-P 15 JULY 01	STATIC LINE STOW MODIFICATION	Venckew	TJR	SBCCOM	24	3	00
10-1670-243-23-P 15 JULY 01	STATIC LINE STOW MODIFICATION	C/W	TJR	SBCCOM	24	6	01

- 1. **Modification Work Order Compliance Completed.**
- 2. **Modification Completed By Unknown Due To Lost Original Log Record.**

- b. **MWO Title.** Enter a short, abbreviated title extracted from the MWO prescribing the work.
 - c. **Modified by.** Enter the last name of the individual who has performed the modification. If the original log record for the item has been lost, and it has been ascertained through inspection that a particular modification has been accomplished, the entry for this column will be CIW, complied with, which signifies the applicable MWO has been complied with.
 - d. **Inspected by.** The individual who accomplished the inspection, required after modification, will sign this entry with last name only.
 - e. **Unit.** Enter the unit designation responsible for performing the MWO or, in the event of a lost log record, the unit to which the inspector is assigned.
 - f. **Date.** Enter the day, month, and year the modification work was completed.
4. **Unit and Direct Support Repair and Inspection Data.** When an item is initially received from a supply source, and a technical/rigger-type inspection is performed, the inspection accomplishment will be documented on the Unit and Intermediate Repair and Inspection Data page of the item log record. Additional entries will also be made on this page each time the item is repaired, or is administered an inspection, in compliance with a one-time inspection dictated by a Maintenance Advisory Message (MAM) or Ground Precautionary Message (GPM). The page completion criteria are as follows:
- a. **Type of repair.** Enter the type of repair, completion of initial inspection, repair accomplishment, and GPM/MAM inspection compliance.
 - b. **Inspection by.** The individual, who accomplished the inspection required, will sign this entry with last name.
 - c. **Unit.** Enter the unit designation responsible for performing the type of repair.
 - d. **Date.** Enter the day, month, and year the repair was performed.

The diagram shows a form divided into two main sections: 'UNIT & INTERMEDIATE' on the left and 'REPAIR & INSPECTION DATA' on the right. Three numbered arrows point to the following sections:

- 1: Points to the 'TYPE OF REPAIR' section, which contains the text 'INITIAL INSPECTION'.
- 2: Points to the 'REPAIR & INSPECTION DATA' section, specifically to the 'INSP BY' column, which contains the name 'Venekia'.
- 3: Points to the 'REPAIR & INSPECTION DATA' section, specifically to the 'DATE' columns, which contain the date '12 2 01'.

Other visible text in the form includes 'I SEC and 4 Lima Replaced' and 'TM 10-1670-300-20-1' in the 'TYPE OF REPAIR' section, and a table with columns for 'UNIT', 'DAY', 'MONTH', and 'YEAR' in the 'REPAIR & INSPECTION DATA' section.

1. Completion Of Initial Inspection
2. Repair Accomplishment
3. GPM/MAM Inspection Compliance

5. **Note page.** A page is provided at the back of a parachute log record to accommodate recording additional data pertinent to the serviceability of an item. This shall also include the month and year the item was placed in service.

NOTE

A parachute log record that is completely filled out, lost, illegible, or in an otherwise unserviceable condition, will be replaced with a serviceable log record.

6. **Replacing a filled out or unserviceable log record.**

- a. Using a suitable blue or black marking device, enter NEW BOOK on the outside front cover of the replacement log record.
- b. Transcribe the information from the inside front cover of the original log record to the inside front cover of the replacement log record. If the original data is illegible or missing, use the item information data block to collect the required data.
- c. In the replacement log record; transcribe the initial and last entry made on the Jump, Inspection, and Repack Data page of the original log record.
- d. Transcribe all data from the remaining pages of the original log record; to the appropriate pages of the replacement log record.
- e. After all original data has been transcribed destroy the original log record.

7. **Replacing a lost log record.**

NOTE

Any time a log record is discovered missing from an item, a replacement log record will be initiated during inspection, as applicable.

- a. Using a suitable blue or black marking device, enter NEW BOOK at the top of the inside front cover of the replacement log record.
- b. Accomplish the log record inside front cover as prescribed above.

- c. The age life of the item (if applicable) will be obtained from the date placed in service (initial) and other applicable data on the jump, inspection, and Repack Data page of the log record, as detailed above. Enter IN, if the date placed in service is known. If not known, enter UNK.
- d. If it can be ascertained by inspection that a previous MWO or GPM/MAM has been complied with, applicable entries will be made on the appropriate page of the replacement log record.
- e. Attach the replacement log record to the log record/inspection data pocket using the procedures above.

RECEIPT OF USED ANCILLARY EQUIPMENT FOR PERSONNEL PARACHUTE SYSTEMS

Upon initial receipt of used equipment, proceed as follows:

1. Follow procedures given in the General Procedures for Ancillary Equipment For Personnel Parachute Systems paragraph, above, and check each component for excessive wear and tear.
2. If defects or damages are discovered, process the parachute for maintenance at the maintenance level assigned by the Maintenance Allocation Chart (MAC), WP 0034 00.

AFTER USE RECEIPT

When an item is received at the maintenance activity, following its use by the parachutist during air delivery, it must be cleaned (WP 0009 00) before it can be returned to service. If an item is issued but is not used, it does not need to be cleaned however, it must be given a routine inspection by a qualified parachute rigger (MOS 92R).

END OF WORK PACKAGE

UNIT MAINTENANCE
ANCILLARY EQUIPMENT FOR PERSONNEL PARACHUTE SYSTEM
PREVENTIVE MAINTENANCE CHECKS AND SERVICES (PMCS), INTRODUCTION

GENERAL

The following describe PMCS procedures on the unit and direct support levels. The PMCS table has been provided to ensure the Ancillary Equipment for Personnel Parachute Systems are in proper operating condition, and ready for its primary mission.

SCOPE

The following work packages (WP 0005 00 through WP 0029 00) contain maintenance procedures that are the responsibility of the specified technician, as authorized by the Maintenance Allocation Chart (MAC), and the Source, Maintenance, and Recoverability (SMR) coded items that are identified in the Repair Parts and Special Tools List (RPSTL).

MAINTENANCE FUNCTIONS/PROCEDURES

Each of the mentioned work packages above identifies a maintenance function specified in the MAC. All maintenance procedures required to complete a maintenance function are identified under THIS TASK COVERS: in the order in which the work is most logically accomplished.

DROP TESTING CRITERIA

Drop-testing of aerial delivery equipment consist of physically airdropping an item from an aircraft in flight. The drop-test is used as a means of proving the serviceability of an item or checking parachute rigger proficiency, and will only be performed under the supervision of qualified parachute rigger personnel who satisfy the supervisory requirements outlined in AR 750-32. Drop-testing will usually be conducted by an activity responsible for the inspection and maintenance of airdrop equipment, which includes either parachute packing or airdrop load rigging. The criteria required to accomplish a drop test is as follows:

1. To drop-test a troop-type personnel parachute, a qualified parachute rigger will jump the parachute and the applicable type parachute will be released under conditions that are consistent with the requirements for a personnel jump or equipment drop.
2. During the drop-test of any type parachute, the deployment of the parachute will be thoroughly monitored and observed to detect any indication of malfunction or defect. A subsequent record of the applicable parachute log record will be entered into the applicable log record using procedures outline in WP 0004 00.
3. Any type of airdrop equipment that indicates evidence of malfunction/defect during, or after, a drop-test will be disposed of as prescribed in WP 0008 00.
4. A personnel parachute that is considered to have contributed to the injury of an individual parachutist (critical or fatal) will be disposed of as prescribed in WP 0008 00, Equipment Disposition.
5. Airdrop equipment that does not reflect evidence of malfunction or defect upon completion of a drop-test will be administered a technical/rigger-type inspection as outlined in WP 0008 00. If serviceable, the item(s) may then remain in use.

END OF WORK PACKAGE

UNIT MAINTENANCE
ANCILLARY EQUIPMENT FOR PERSONNEL PARACHUTE SYSTEM
PREVENTIVE MAINTENANCE CHECKS AND SERVICES

GENERAL

The following describe PMCS procedures at the unit level. The PMCS table has been provided to ensure the Ancillary Equipment for Personnel Parachute Systems are in proper operating condition, and ready for its primary mission.

Frequency of Performing PMCS. PMCS will be performed before equipment is rigged for use, during modification and repair after use, or at any time deemed necessary by the air delivery equipment maintenance officer.

PMCS Columnar Entries Table 1.

Item Number. The item number column shall be used as a source of the item number required for the TM Number column on DA Form 2404 (Equipment Inspection and Maintenance Worksheet), when recording the results of the PMCS.

Interval. This column identifies the required PMCS interval.

Item to be Inspected. Contains the common name of the item to be inspected.

Procedures. Provides a brief description of the procedures by which the checks are to be performed.

Not Fully Mission Capable If: Column. Information in this column tells you what faults will keep your equipment from being capable of performing its primary mission. If you perform check and service procedures that show faults listed in this column, do not operate the equipment. Follow standing operating procedures for maintaining the equipment or reporting equipment failure.

Recording Defects. All defects discovered during the inspection will be recorded using the applicable specifics in DA Pamphlet 738-750, DA Pamphlet 738-751 and TB 43-0002-43.

Over Age Items. During any inspection, or at any time that an item is found to be over age (i.e., shelf/service-life has expired as specified in TB 43-0002-43), the item will be removed from service, condemned, and tagged, in accordance with DA PAM 738-751.

Conservation of Resources. To conserve time and labor, and to avoid evacuation to a direct support maintenance activity, unit/detachment commanders may designate, in writing, rigger personnel to accomplish classification inspection of over age air delivery equipment and the classification of Beyond Economical Repair (BER).

Inspection Function Requirement. Normally, air delivery equipment maintenance personnel at a packing, rigging, or repair activity will perform a technical/rigger-type inspection. The inspection of initial receipt items will be performed as a separate function from packing or rigging activity; the item to be inspected will be placed in proper layout on a packing table or suitable sized floor area.

Should defect or damage be discovered at any point during the inspection, the inspection will be terminated and the applicable item will be processed and forwarded to repair activity. The repair activity, in turn, will conduct a technical/rigger-type inspection that will be performed by only those parachute rigger personnel cited in AR 750-32.

Any defect discovered during a unit level repair activity inspection, that exceeds the capability of that activity, will require the affected item to be evacuated to a direct support maintenance function.

Lubrication Instructions. Apply a limited amount of “zipper ease” lubricant to the slide fastener on any ancillary equipment component when it becomes difficult to operate.

Table 1. Unit Preventive Maintenance Checks and Services

Item No.	Interval	Location Item to Check/Service	Procedure	Not Fully Mission Capable If:
01	Before	Extension Static Line, Standard, 5-Foot	Check entire length of extension for loose or broken stitches, missing or damaged snap hook (1) or safety pin/lanyard (2). Look for frays, cuts or tears in webbing (3) and sleeve (4).	Cuts, tears or frayed areas. Snap hook (1) or pin lanyard (2) damaged or missing.

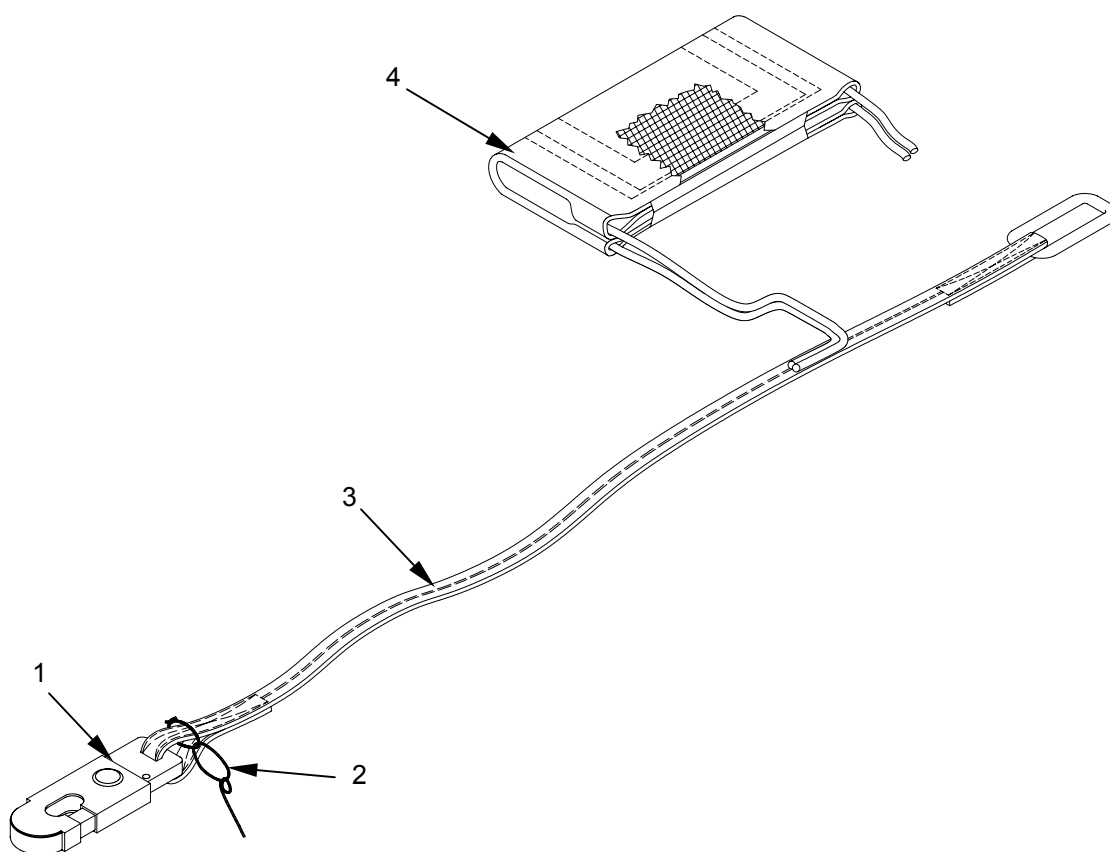

Table 1. Unit Preventive Maintenance Checks and Services-Continued

Item No.	Interval	Location Item to Check/ Service	Procedure	Not Fully Mission Capable If:
02	Before	Accessory Set, SCUBA	Check waistband (1), support (2) and harness backstraps (3) for frays, cuts or tears and missing hardware. Check for open or loose stitches. Check shield (4) for deformation, burrs or sharp edges.	Cuts, frays or tears in any strap. Missing hardware on straps. Shield damaged.

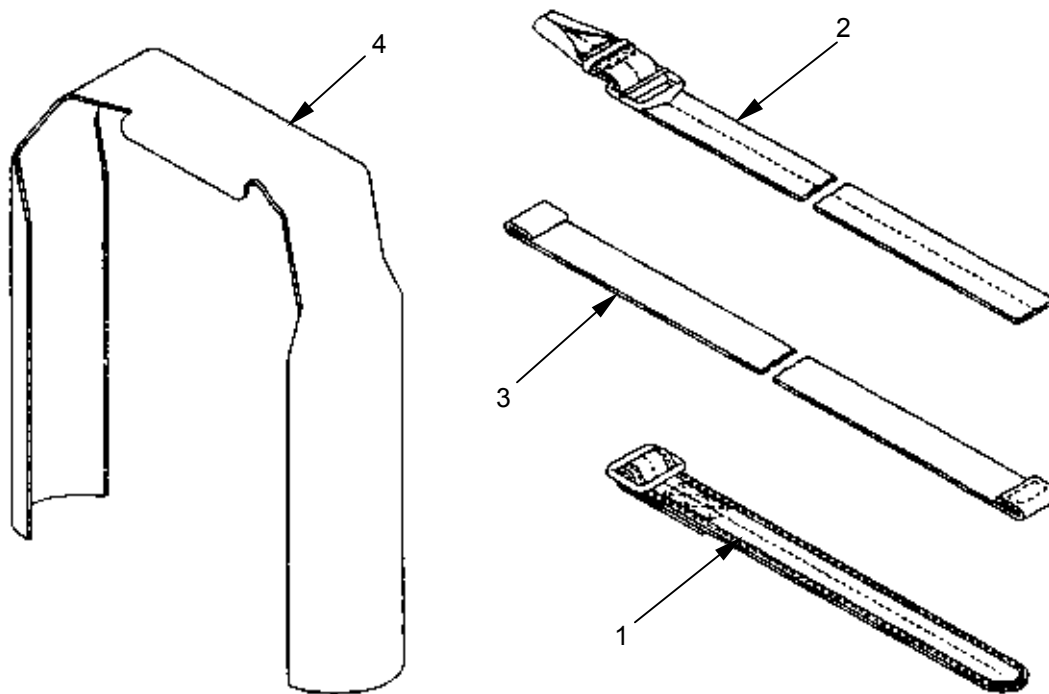

Table 1. Unit Preventive Maintenance Checks and Services-Continued

Item No.	Interval	Location Item to Check/ Service	Procedure	Not Fully Mission Capable If:
03	Before	Lowering Line, 15-Foot	<p>Webbing (1). Inspect for cuts, frays, tears, and marred or illegible markings.</p> <p>Stitching. Inspect for loose or broken stitching damaged or missing fastener tapes.</p> <p>All Hardware & Functional Fittings. Inspect for improper operation, rust, corrosion, burrs, & cracks. Gap between the opening gate does not exceed 5/64 of an inch.</p>	<p>Cut, Tears or frays in webbing (1) or pull to release lanyard (2). Missing or damaged hardware.</p>

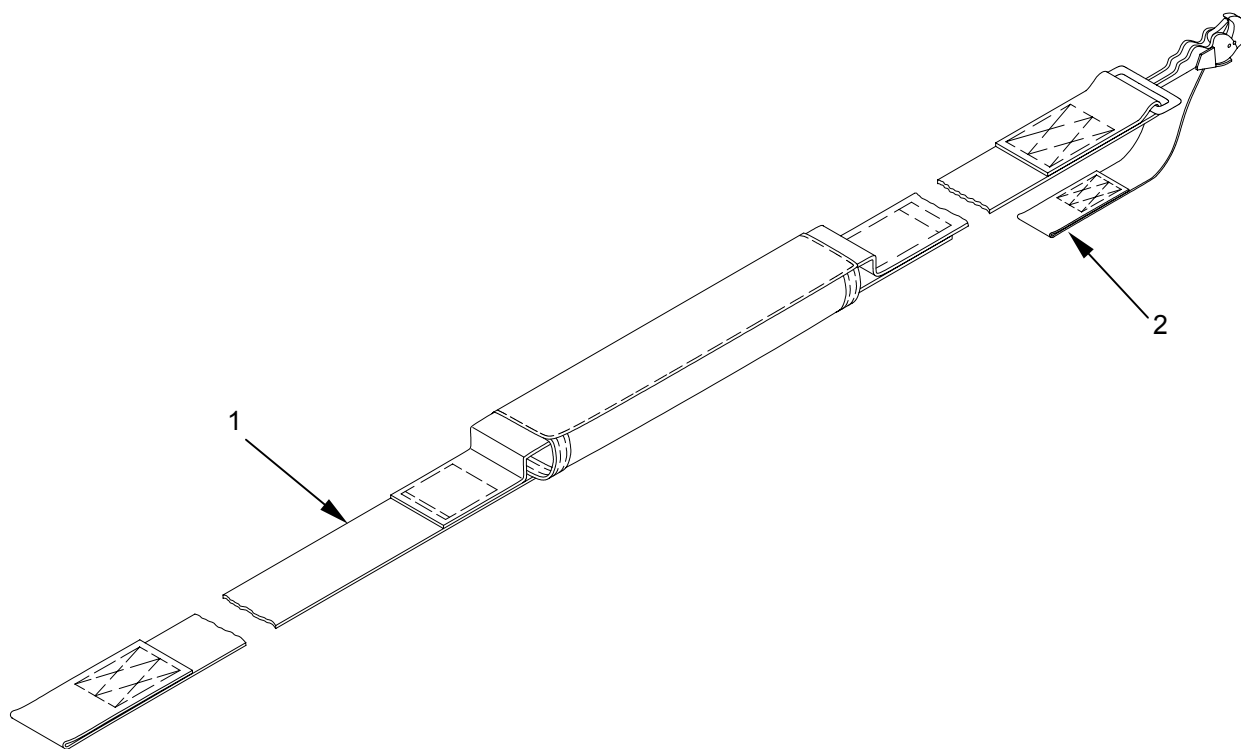

Table 1. Unit Preventive Maintenance Checks and Services-Continued

Item No.	Interval	Location Item to Check/ Service	Procedure	Not Fully Mission Capable If:
04	Before	Jump Pack Dragon Missile	Check Jump Pack Dragon Missile (1) for missing parts, loose or broken stitches, frayed, worn or cuts, tears, and holes in webbing. Bent or otherwise damaged hardware.	Cuts, tears frayed area in webbing. Missing or damaged hardware.

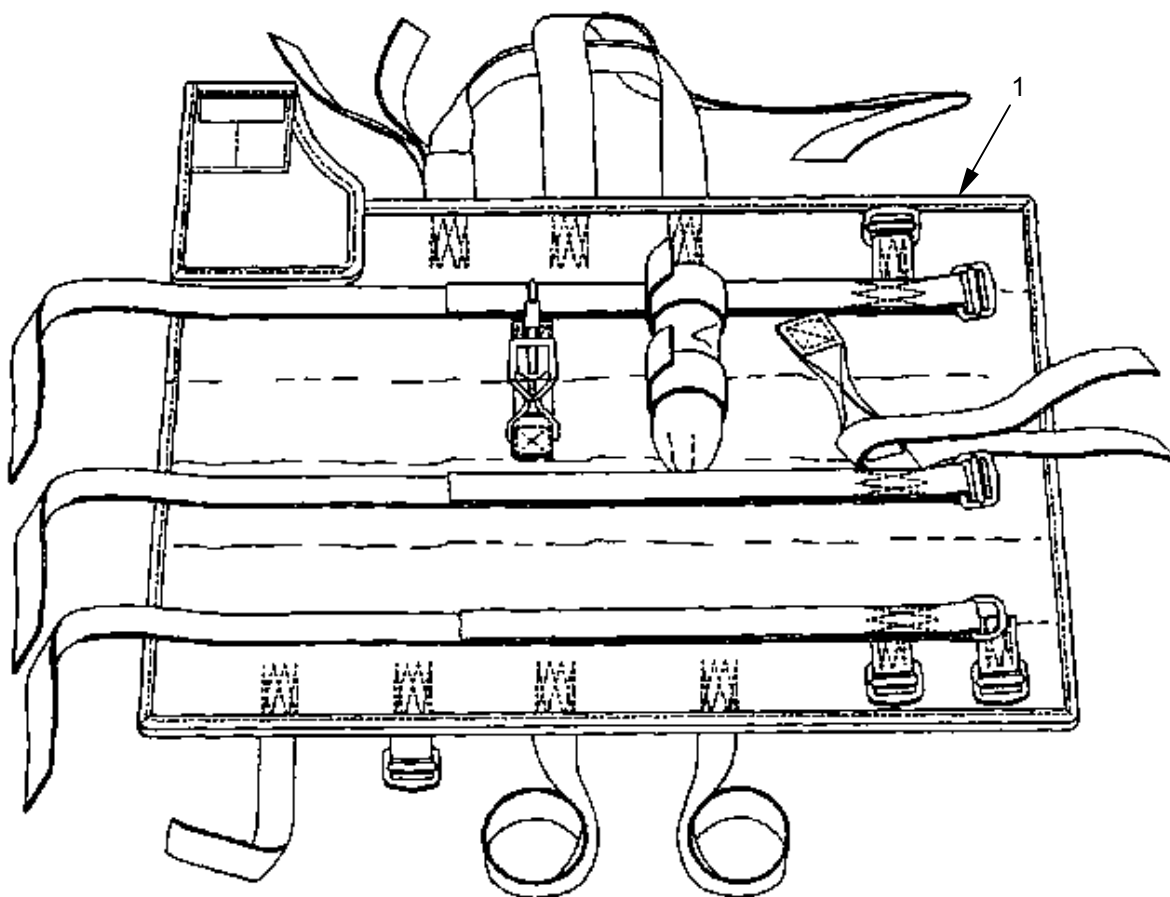

Table 1. Unit Preventive Maintenance Checks and Services-Continued

Item No.	Interval	Location Item to Check/ Service	Procedure	Not Fully Mission Capable If:
05	Before	Harness, Single Point Release	Inspect Harness, Single Point Release (1) for loose or broken stitches and frayed, worn or cut webbing. Bent or damaged hardware.	Cuts, tears and frayed areas in webbing. Missing or damaged hardware.

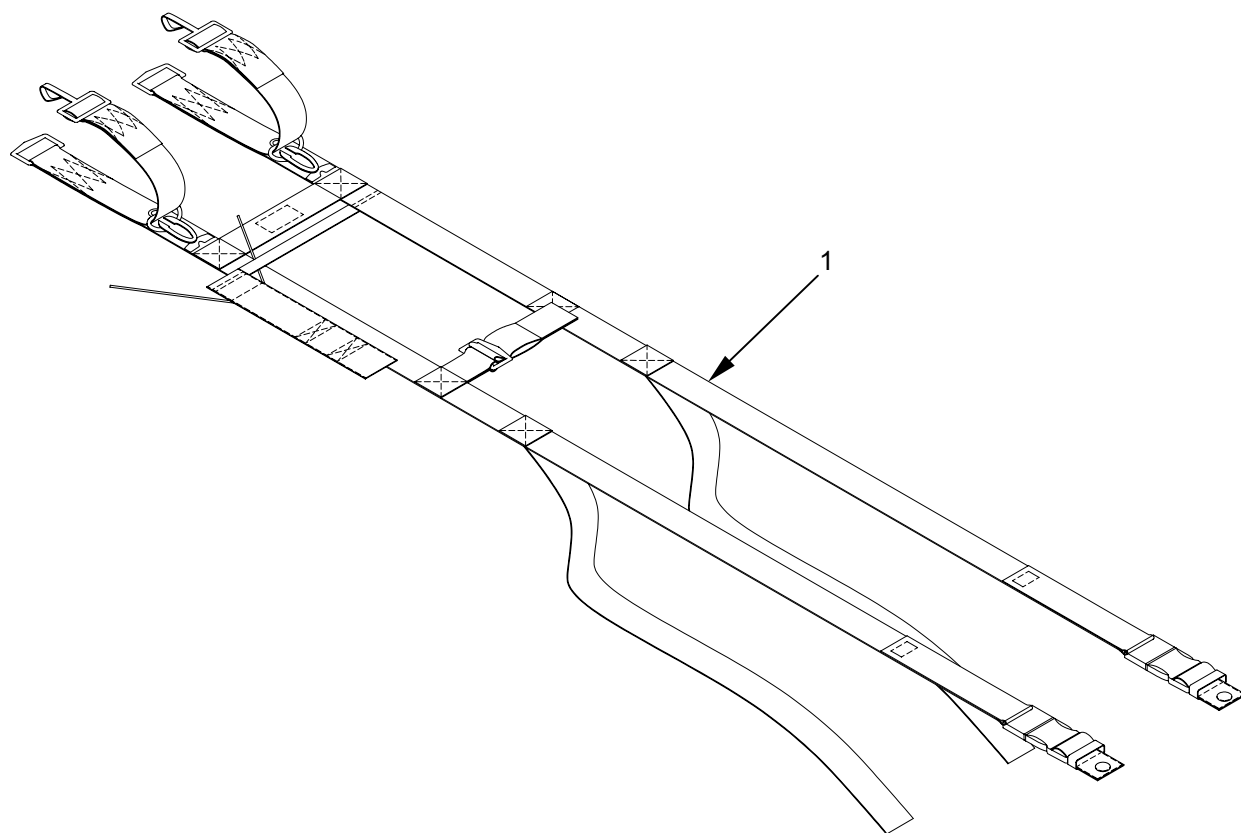

Table 1. Unit Preventive Maintenance Checks and Services-Continued

Item No.	Interval	Location Item to Check/ Service	Procedure	Not Fully Mission Capable If:
06	Before	Pack Assembly, AT4	Inspect Pack Assembly, AT4 (1) for loose or broken stitches or frayed, worn and cut areas in webbing. Bent, missing or damaged hardware.	Open seams, cuts, tears or frays in webbing. Missing or damaged hardware.

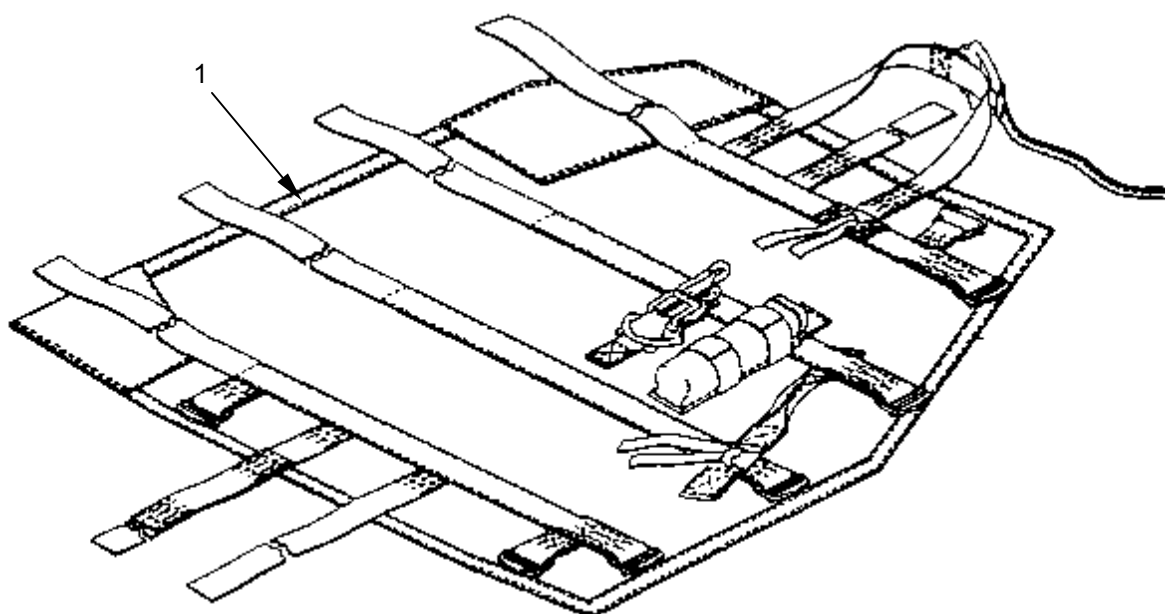

Table 1. Unit Preventive Maintenance Checks and Services-Continued

Item No.	Interval	Location Item to Check/ Service	Procedure	Not Fully Mission Capable If:
07	Before	Case Parachutist's Individual Weapon (cotton)	Inspect Case Parachutist's Individual Weapon (1) for loose or broken stitches or frayed, worn, and cut areas in fabric. Bent, missing or damaged hardware.	Open seams, cuts, tears or frays in fabric. Missing or damaged hardware.

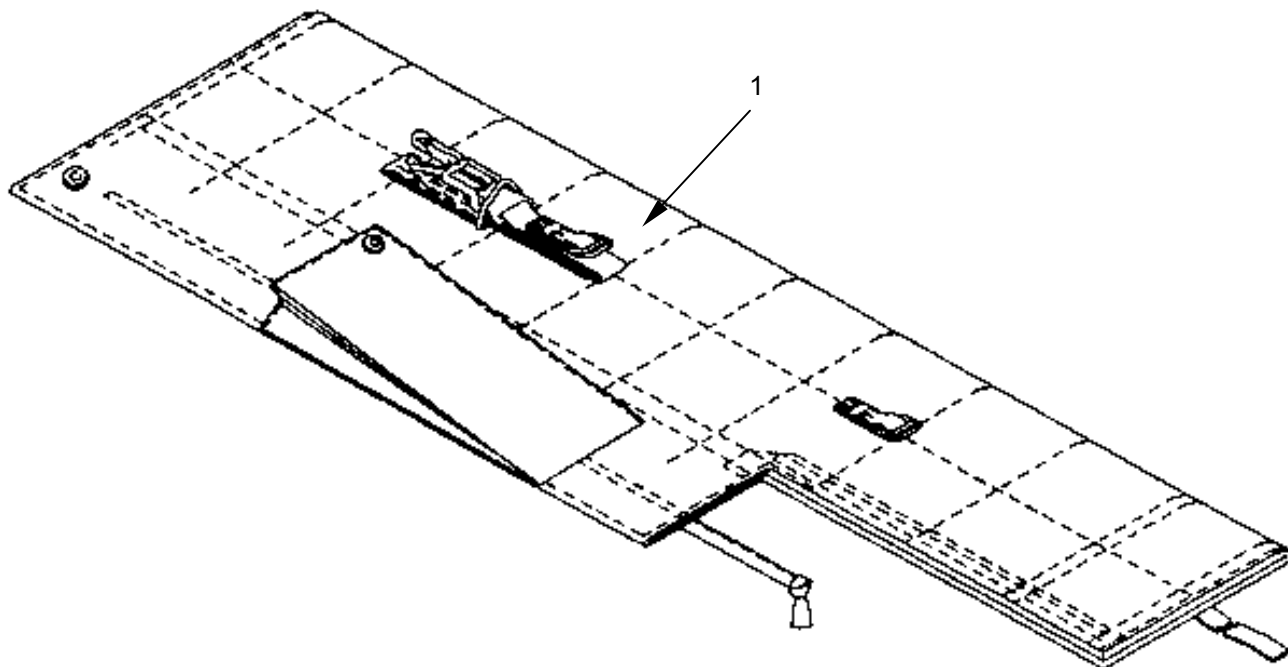

Table 1. Unit Preventive Maintenance Checks and Services-Continued

Item No.	Interval	Location Item to Check/ Service	Procedure	Not Fully Mission Capable If:
08	Before	Case Parachutist's Individual Weapon (nylon)	Inspect Case Parachutist's Individual Weapon (1) for loose or broken stitches or frayed, worn, and cut areas in fabric. Bent, missing or damaged hardware.	Open seams, cuts, tears or frays in fabric. Missing or damaged hardware.

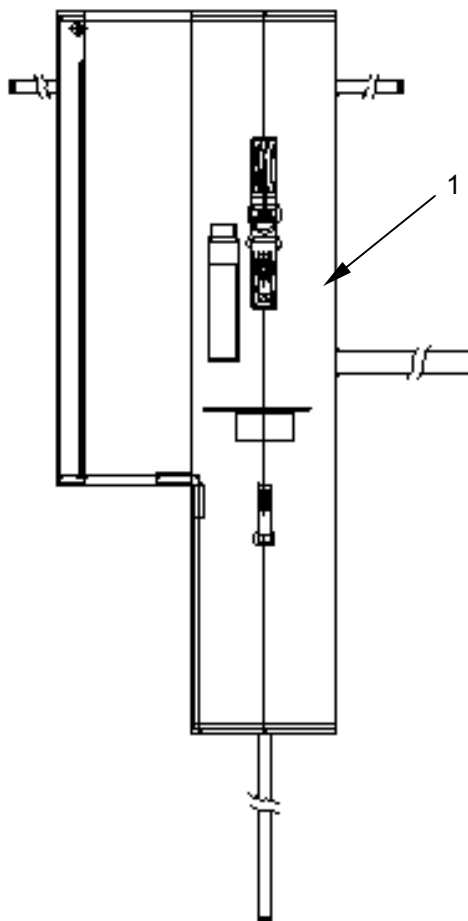

Table 1. Unit Preventive Maintenance Checks and Services-Continued

Item No.	Interval	Location Item to Check/ Service	Procedure	Not Fully Mission Capable If:
09	Before	Case Parachutist's Weapon and Individual Equipment	Inspect Case Parachutist's Weapon and Individual Equipment (1) for loose or broken stitches or frayed, worn, and cut areas in fabric. Bent, missing or damaged hardware.	Open seams, cuts, tears or frays in fabric. Missing or damaged hardware.

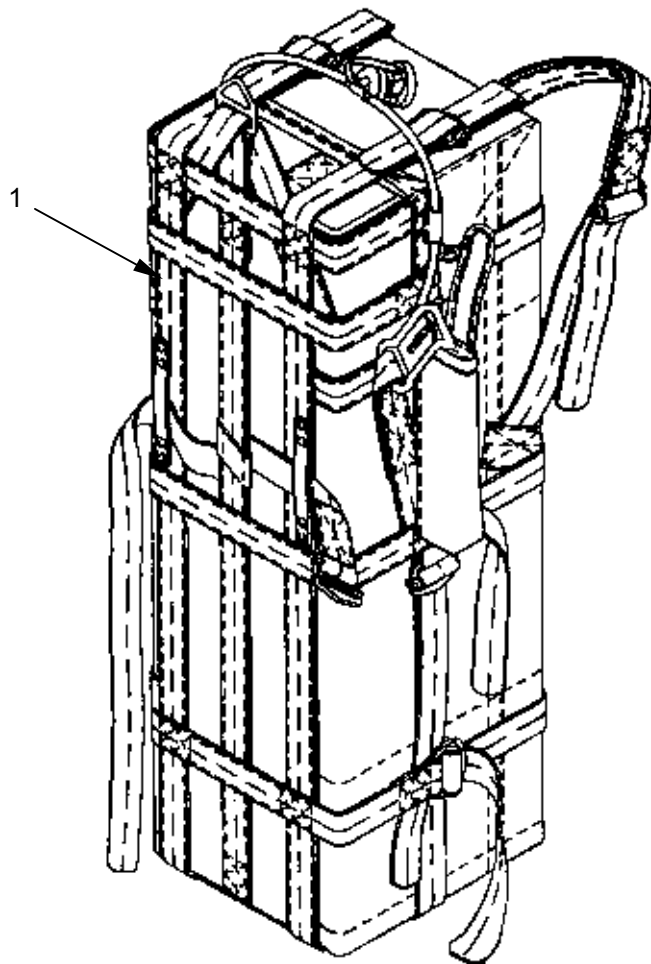

Table 1. Unit Preventive Maintenance Checks and Services-Continued

Item No.	Interval	Location Item to Check/ Service	Procedure	Not Fully Mission Capable If:
10	Before	Jump Pack Stinger Missile	Inspect Jump Pack Stinger Missile (1) for loose or broken stitches, or frayed, worn, and cut areas in fabric. Bent, missing or damaged hardware.	Open seams, cuts, tears or frays in fabric. Missing or damaged hardware.

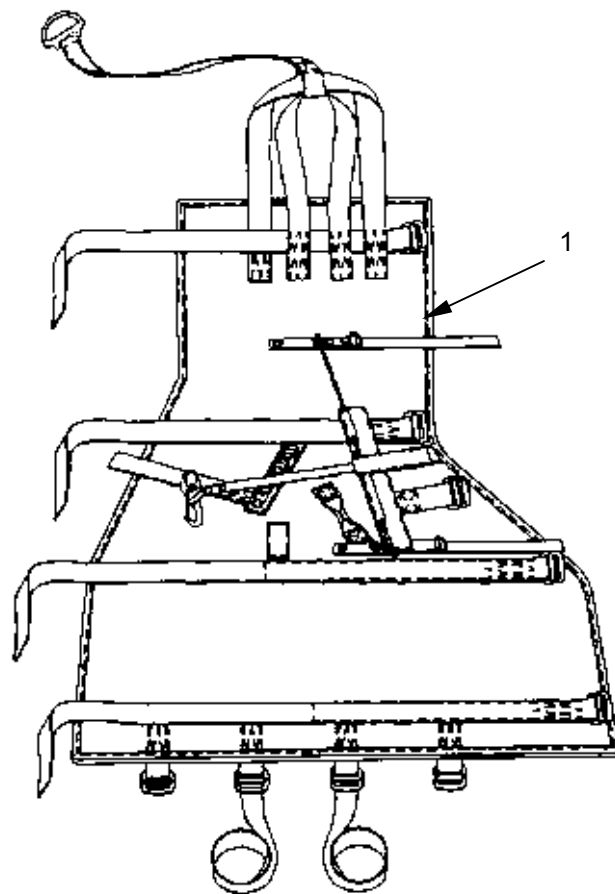

Table 1. Unit Preventive Maintenance Checks and Services-Continued

Item No.	Interval	Location Item to Check/ Service	Procedure	Not Fully Mission Capable If:
11	Before	Release Assembly, Parachutist's Individual Equipment	Inspect Release Assembly, Parachutist's Individual Equipment (1) for loose or broken stitches, or frayed, worn, and cut areas in fabric. Bent, missing or damaged hardware.	Open seams, cuts, tears or frays in fabric. Missing or damaged hardware.

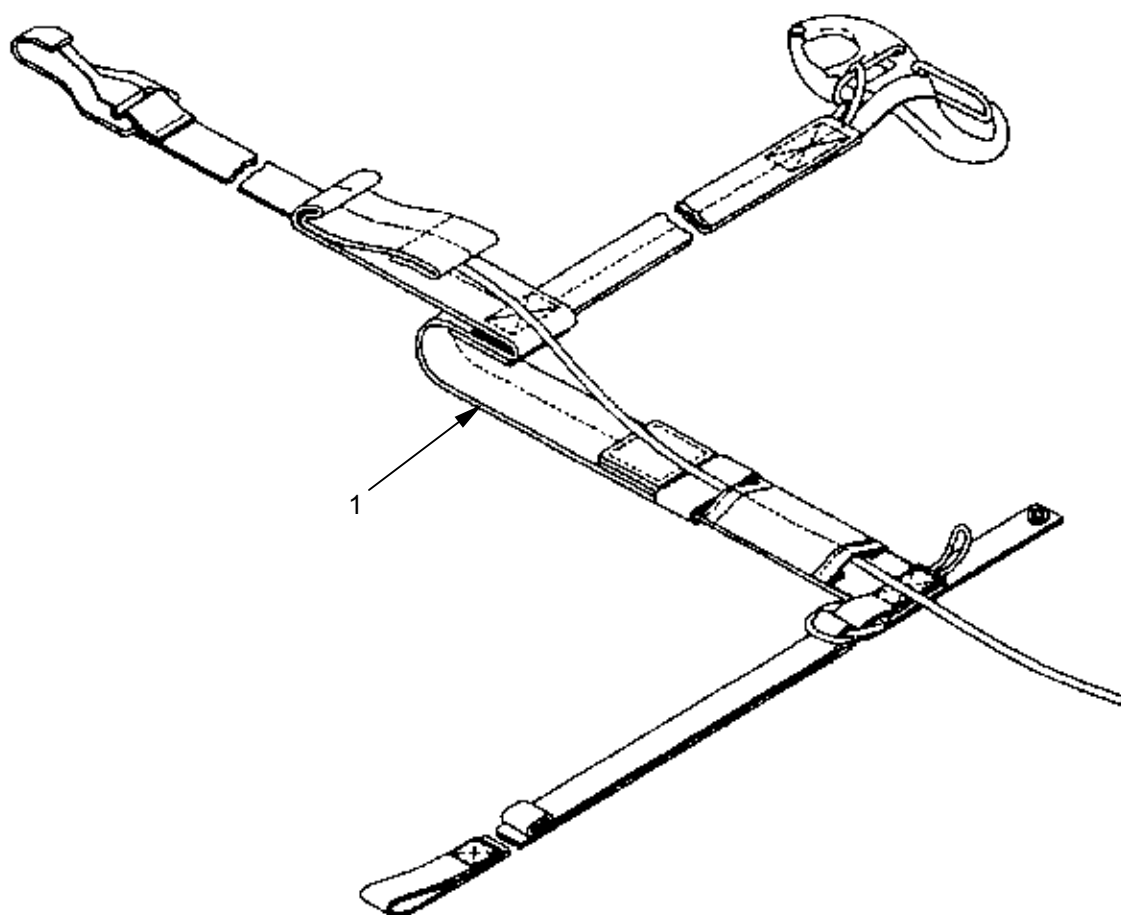

Table 1. Unit Preventive Maintenance Checks and Services-Continued

Item No.	Interval	Location Item to Check/ Service	Procedure	Not Fully Mission Capable If:
12	Before	Container, Front Mount, (AIRPAC)	Inspect Container, Front Mount (1) for loose or broken stitches, or frayed, worn, and cut areas in fabric. Bent, missing or damaged hardware.	Open seams, cuts, tears or frays in fabric. Missing or damaged hardware.

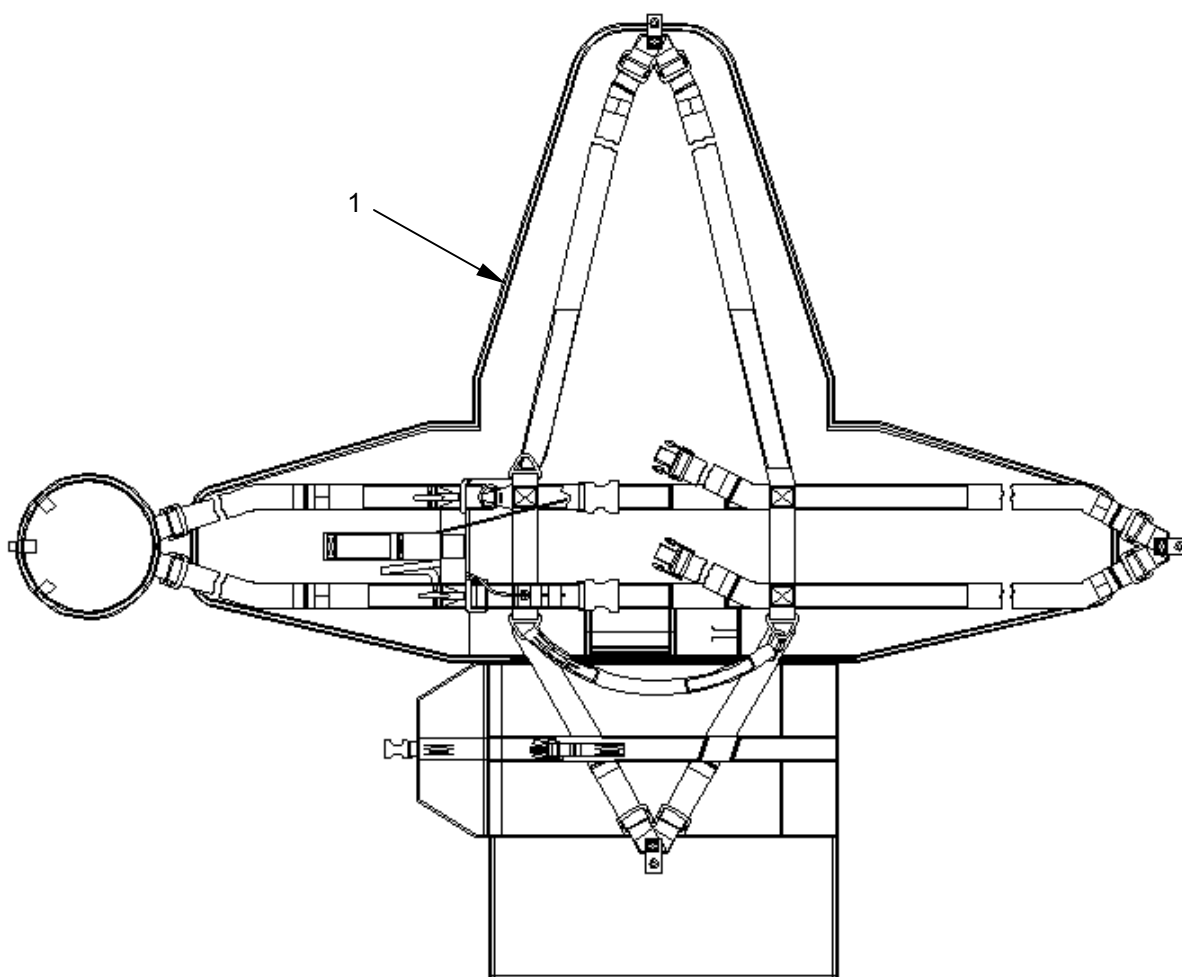

Table 1. Unit Preventive Maintenance Checks and Services-Continued

Item No.	Interval	Location Item to Check/ Service	Procedure	Not Fully Mission Capable If:
13	Before	Container, Side Mount (AIRPAC)	Inspect Container, Side Mount (AIRPAC) (1) for loose or broken stitches, or frayed, worn, and cut areas in fabric. Bent, missing or damaged hardware.	Open seams, cuts, tears or frays in fabric. Missing or damaged hardware.

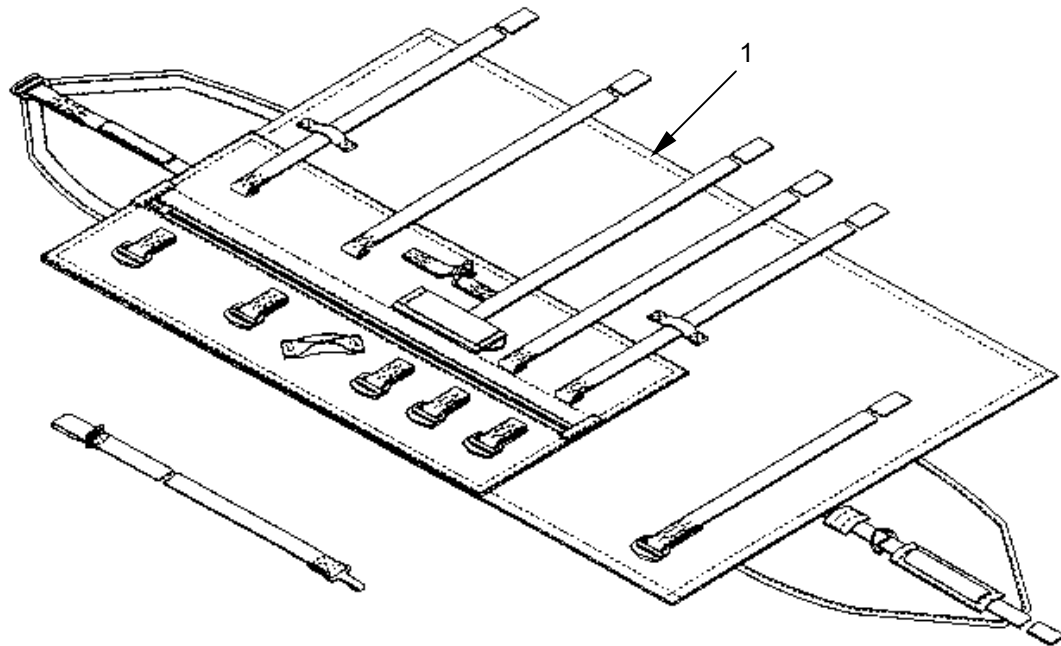

Table 1. Unit Preventive Maintenance Checks and Services-Continued

Item No.	Interval	Location Item to Check/ Service	Procedure	Not Fully Mission Capable If:
01	After	Extension Static Line, Standard, 5-Foot	Check entire length of extension for loose or broken stitches, missing or damaged snap hook (1) or safety pin/lanyard (2). Look for frays, cuts or tears in webbing (3) and sleeve (4).	Cuts, tears or frayed areas. Snap hook (1) or pin lanyard (2) damaged or missing.

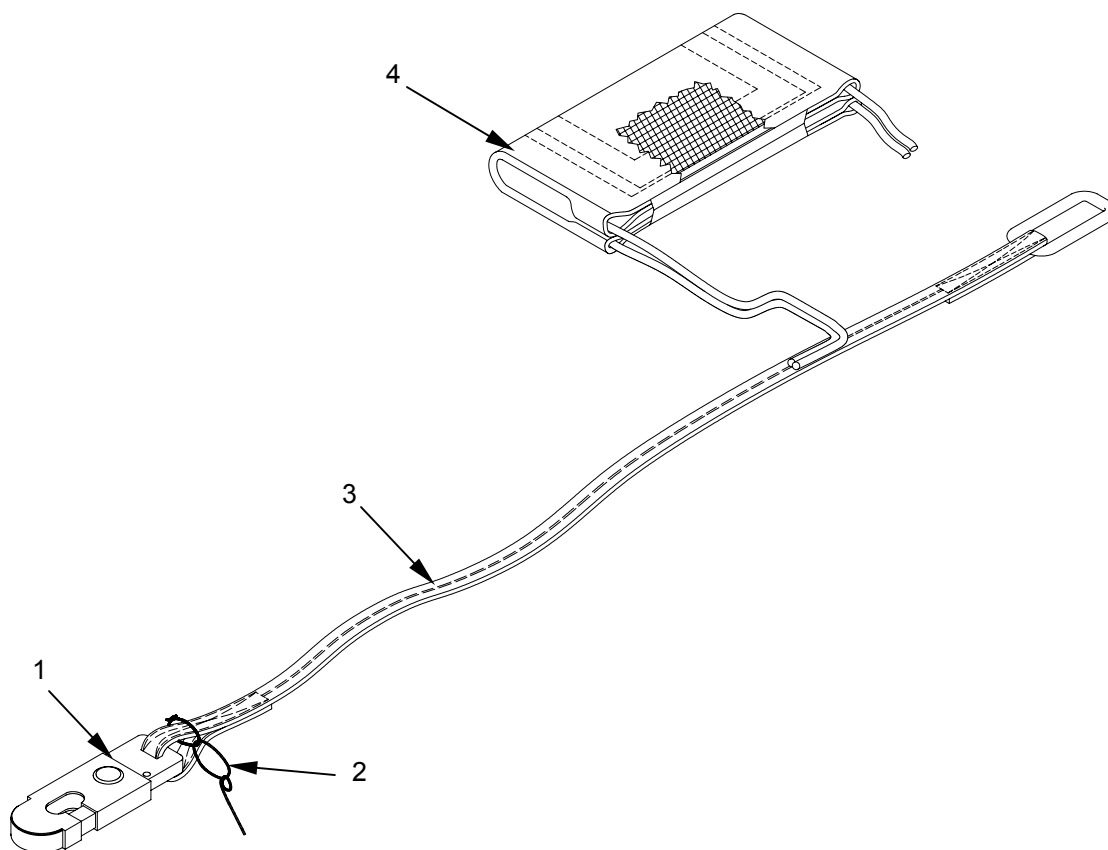

Table 1. Unit Preventive Maintenance Checks and Services-Continued

Item No.	Interval	Location Item to Check/ Service	Procedure	Not Fully Mission Capable If:
02	After	Accessory Set, SCUBA	Check waistband (1), support (2) and harness backstraps (3) for frays, cuts or tears and missing hardware. Check for open or loose stitches. Check shield (4) for deformation, burrs or sharp edges.	Cuts, frays or tears in any strap. Missing hardware on straps. Shield damaged.

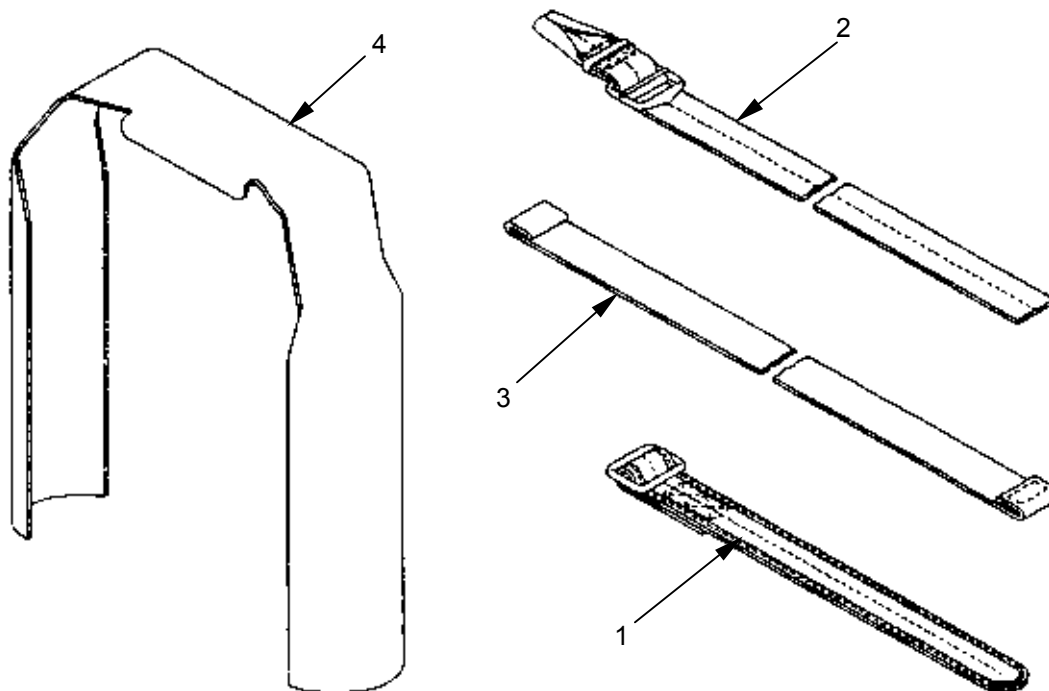

Table 1. Unit Preventive Maintenance Checks and Services-Continued

Item No.	Interval	Location Item to Check/ Service	Procedure	Not Fully Mission Capable If:
03	After	Lowering Line, 15-Foot	<p>Webbing (1). Inspect for cuts, frays, tears, and marred or illegible markings.</p> <p>Stitching. Inspect for loose or broken stitching damaged or missing fastener tapes.</p> <p>All Hardware & Functional Fittings. Inspect for improper operation, rust, corrosion, burrs, & cracks. Gap between the opening gate does not exceed 5/64 of an inch.</p>	<p>Cut, Tears or frays in webbing (1) or pull to release lanyard (2). Missing or damaged hardware.</p>

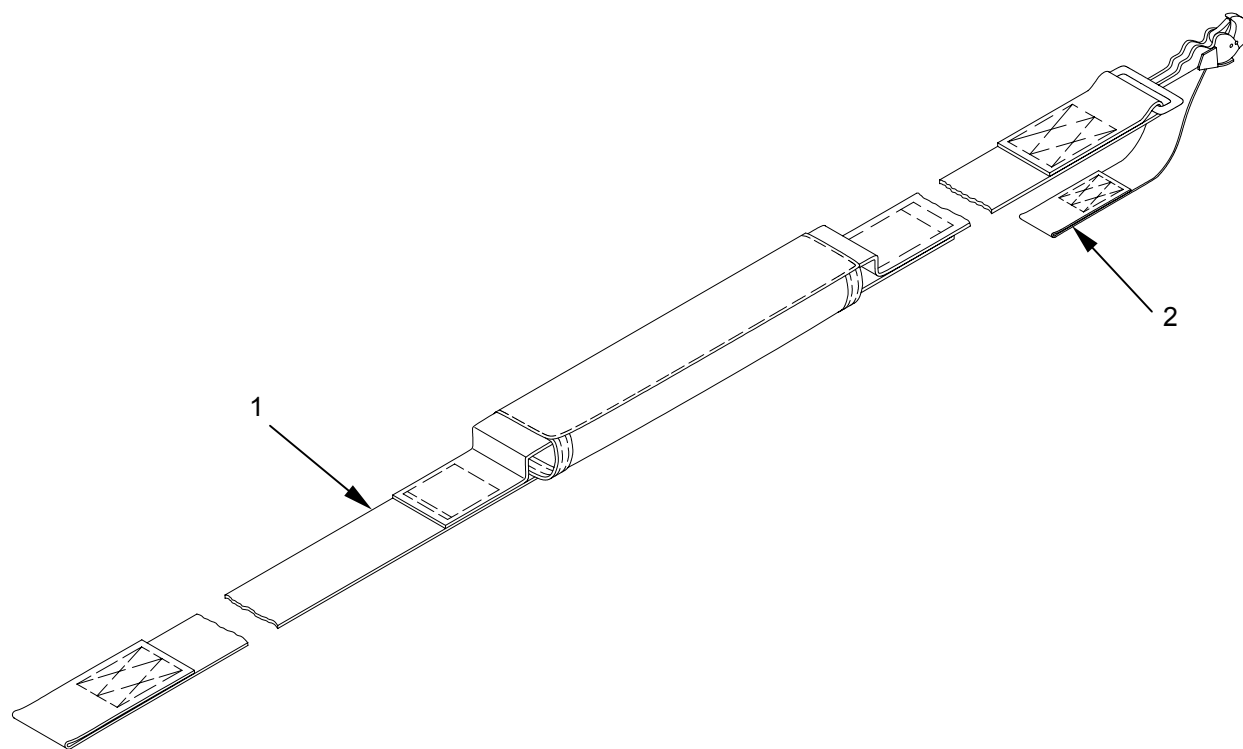

Table 1. Unit Preventive Maintenance Checks and Services-Continued

Item No.	Interval	Location Item to Check/ Service	Procedure	Not Fully Mission Capable If:
04	After	Jump Pack Dragon Missile	Check Jump Pack Dragon Missile (1) for missing parts, loose or broken stitches, frayed, worn or cuts, tears, and holes in webbing. Bent or otherwise damaged hardware.	Cuts, tears frayed area in webbing. Missing or damaged hardware.

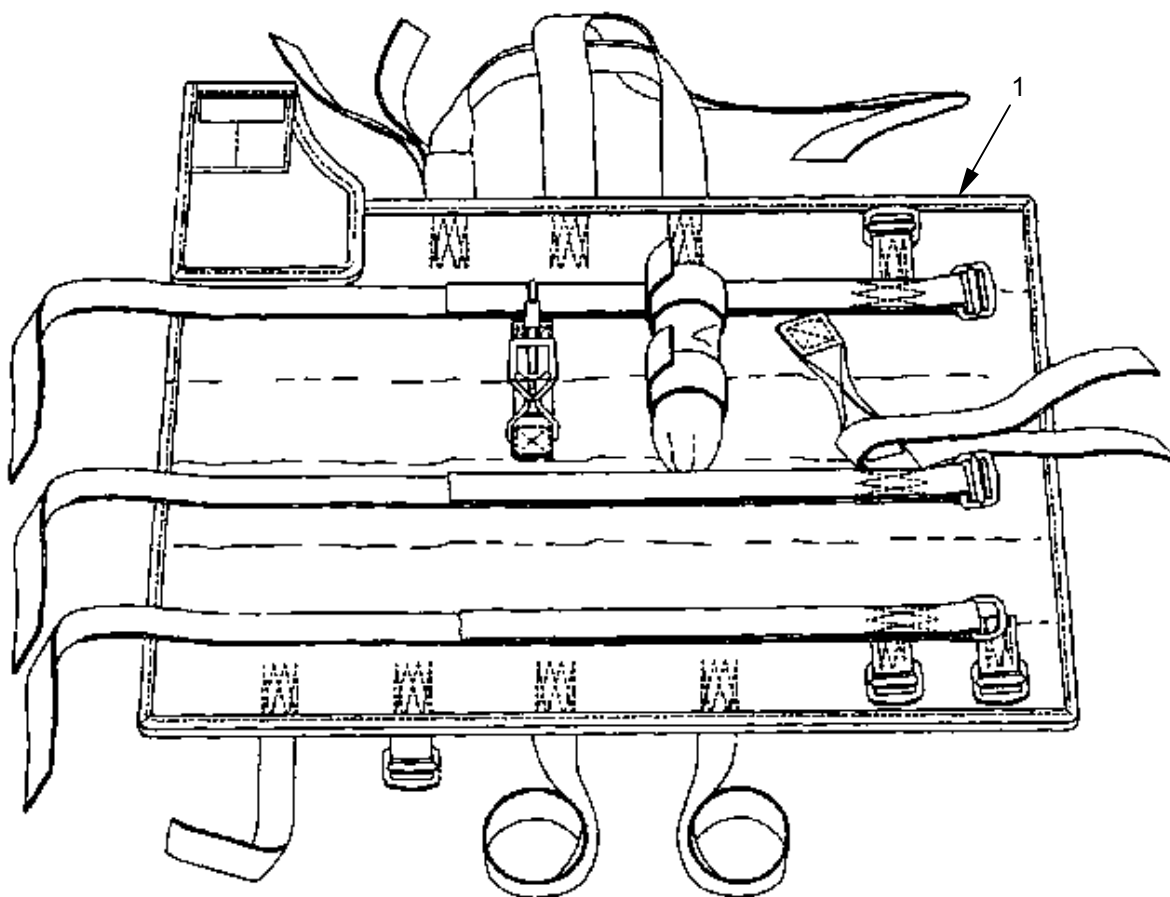

Table 1. Unit Preventive Maintenance Checks and Services-Continued

Item No.	Interval	Location Item to Check/ Service	Procedure	Not Fully Mission Capable If:
05	After	Harness, Single Point Release	Inspect Harness, Single Point Release (1) for loose or broken stitches and frayed, worn or cut webbing. Bent or damaged hardware.	Cuts, tears and frayed areas in webbing. Missing or damaged hardware.

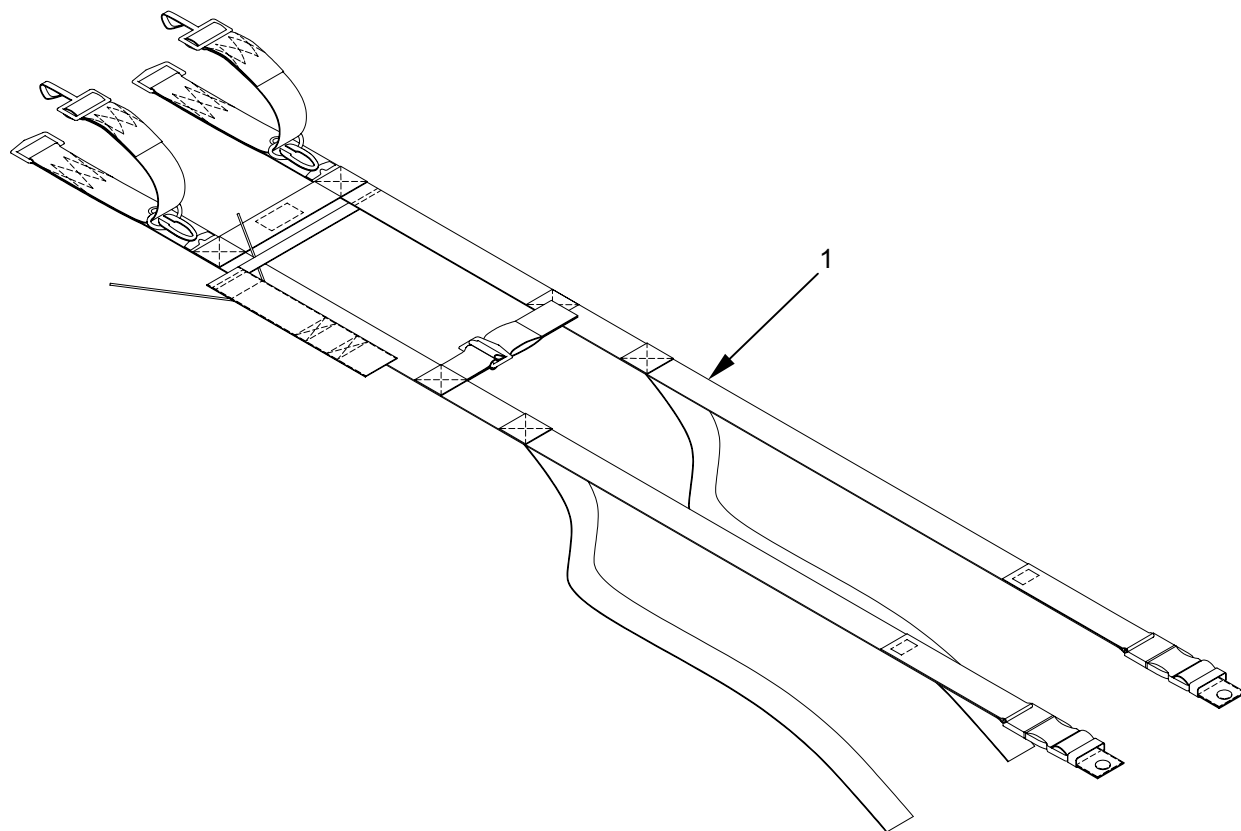

Table 1. Unit Preventive Maintenance Checks and Services-Continued

Item No.	Interval	Location Item to Check/ Service	Procedure	Not Fully Mission Capable If:
06	After	Pack Assembly, AT4	Inspect Pack Assembly, AT4 (1) for loose or broken stitches or frayed, worn and cut areas in webbing. Bent, missing or damaged hardware.	Open seams, cuts, tears or frays in webbing. Missing or damaged hardware.

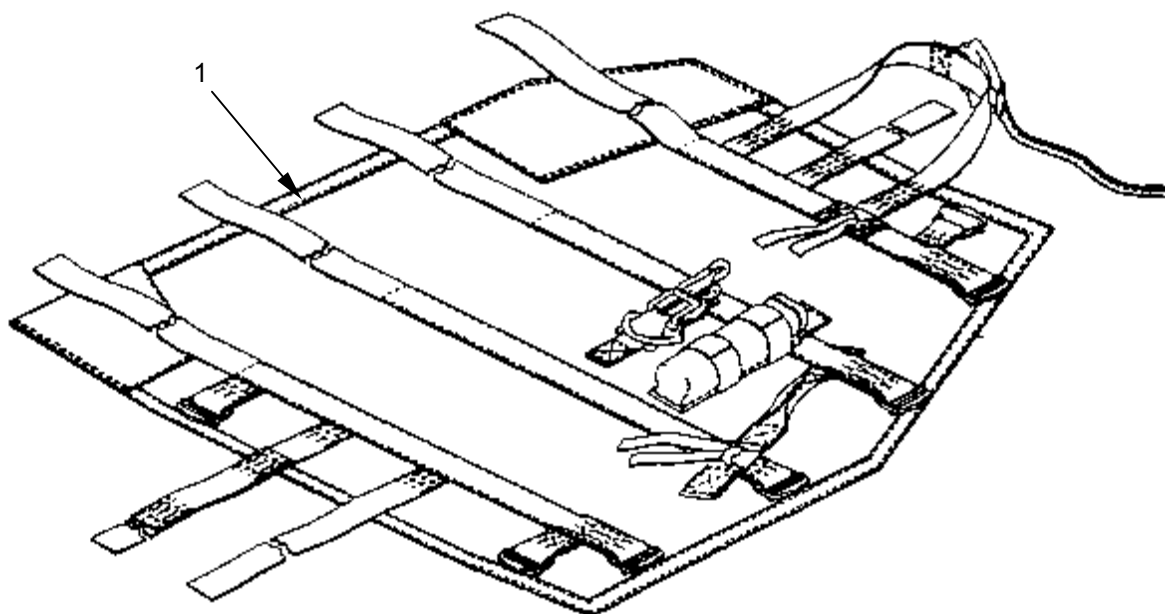

Table 1. Unit Preventive Maintenance Checks and Services-Continued

Item No.	Interval	Location Item to Check/ Service	Procedure	Not Fully Mission Capable If:
07	After	Case Parachutist's Individual Weapon (cotton)	Inspect Case Parachutist's Individual Weapon (1) for loose or broken stitches or frayed, worn, and cut areas in fabric. Bent, missing or damaged hardware.	Open seams, cuts, tears or frays in fabric. Missing or damaged hardware.

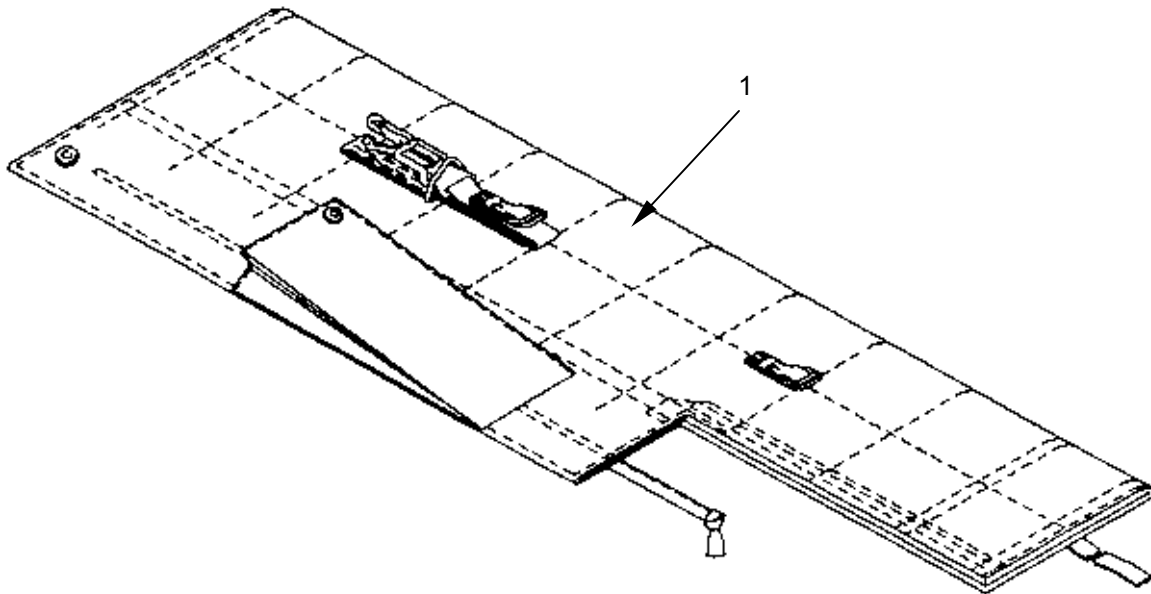

Table 1. Unit Preventive Maintenance Checks and Services-Continued

Item No.	Interval	Location Item to Check/ Service	Procedure	Not Fully Mission Capable If:
08	After	Case Parachutist's Individual Weapon (nylon)	Inspect Case Parachutist's Individual Weapon (1) for loose or broken stitches or frayed, worn, and cut areas in fabric. Bent, missing or damaged hardware.	Open seams, cuts, tears or frays in fabric. Missing or damaged hardware.

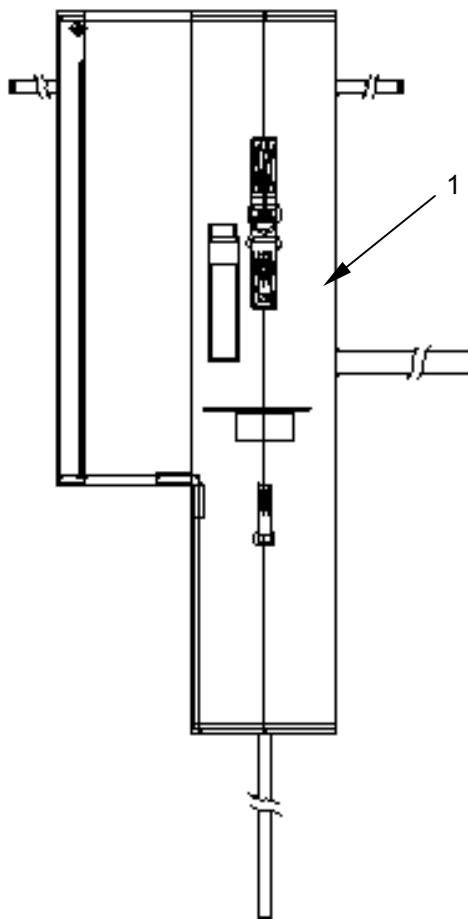

Table 1. Unit Preventive Maintenance Checks and Services-Continued

Item No.	Interval	Location Item to Check/ Service	Procedure	Not Fully Mission Capable If:
09	After	Case Parachutist's Weapon and Individual Equipment	Inspect Case Parachutist's Weapon and Individual Equipment (1) for loose or broken stitches or frayed, worn, and cut areas in fabric. Bent, missing or damaged hardware.	Open seams, cuts, tears or frays in fabric. Missing or damaged hardware.

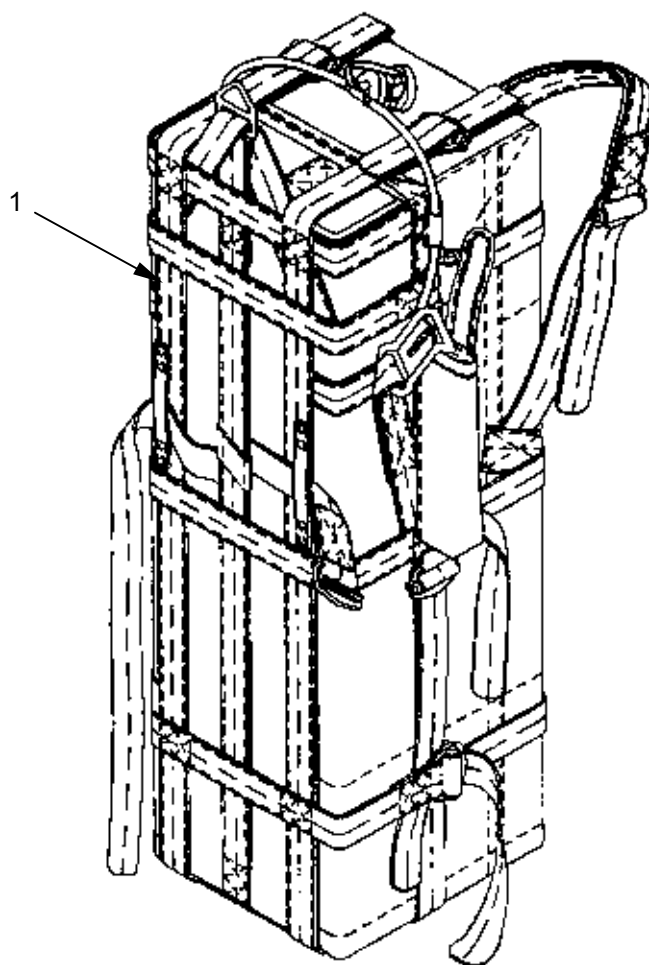

Table 1. Unit Preventive Maintenance Checks and Services-Continued

Item No.	Interval	Location Item to Check/ Service	Procedure	Not Fully Mission Capable If:
10	After	Jump Pack Stinger Missile	Inspect Jump Pack Stinger Missile (1) for loose or broken stitches, or frayed, worn, and cut areas in fabric. Bent, missing or damaged hardware.	Open seams, cuts, tears or frays in fabric. Missing or damaged hardware.

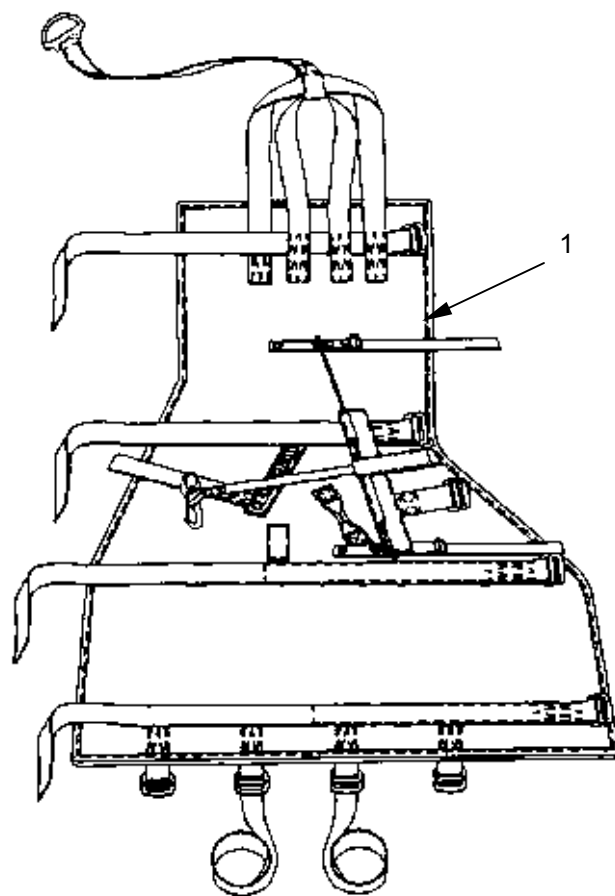

Table 1. Unit Preventive Maintenance Checks and Services-Continued

Item No.	Interval	Location Item to Check/ Service	Procedure	Not Fully Mission Capable If:
11	After	Release Assembly, Parachutist's Individual Equipment	Inspect Release Assembly, Parachutist's Individual Equipment (1) for loose or broken stitches, or frayed, worn, and cut areas in fabric. Bent, missing or damaged hardware.	Open seams, cuts, tears or frays in fabric. Missing or damaged hardware.

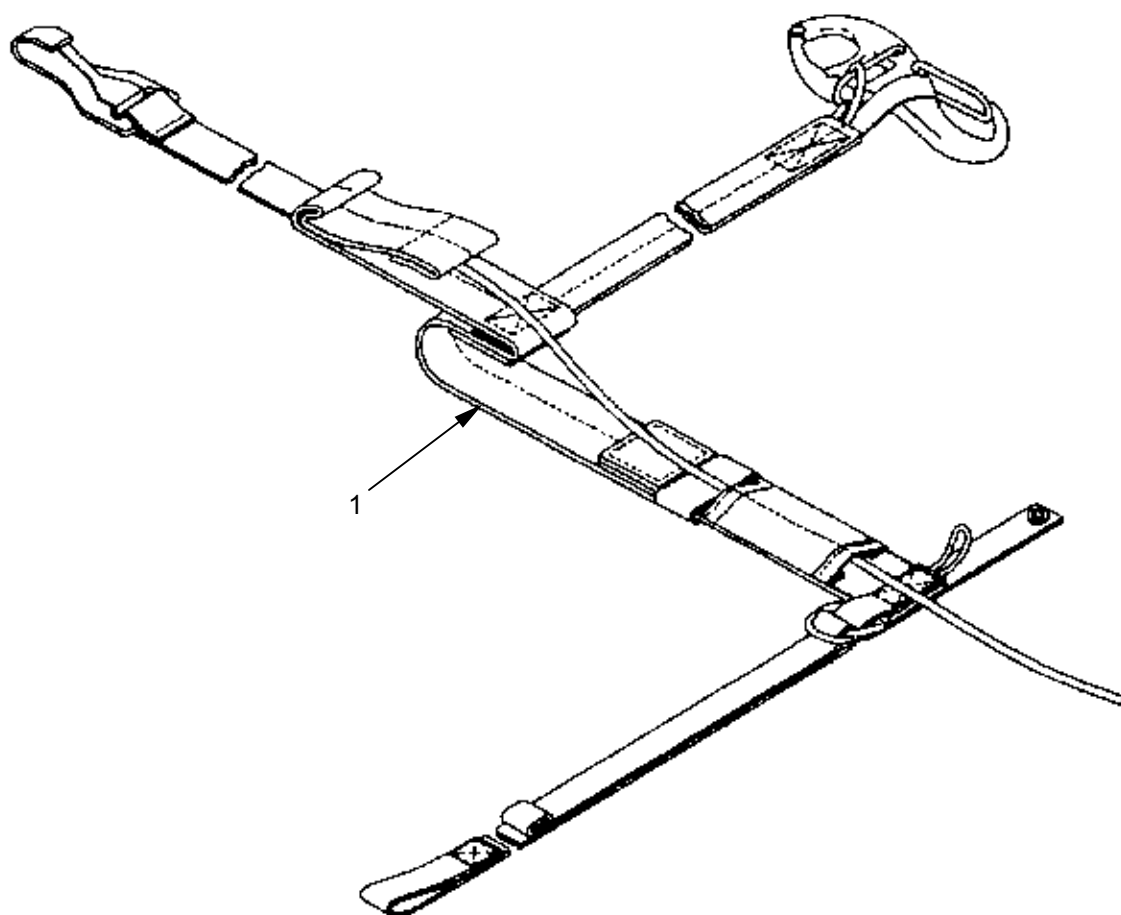

Table 1. Unit Preventive Maintenance Checks and Services-Continued

Item No.	Interval	Location Item to Check/ Service	Procedure	Not Fully Mission Capable If:
12	After	Container, Front Mount (AIRPAC)	Inspect Container, Front Mount (AIRPAC) (1) for loose or broken stitches, or frayed, worn, and cut areas in fabric. Bent, missing or damaged hardware.	Open seams, cuts, tears or frays in fabric. Missing or damaged hardware.

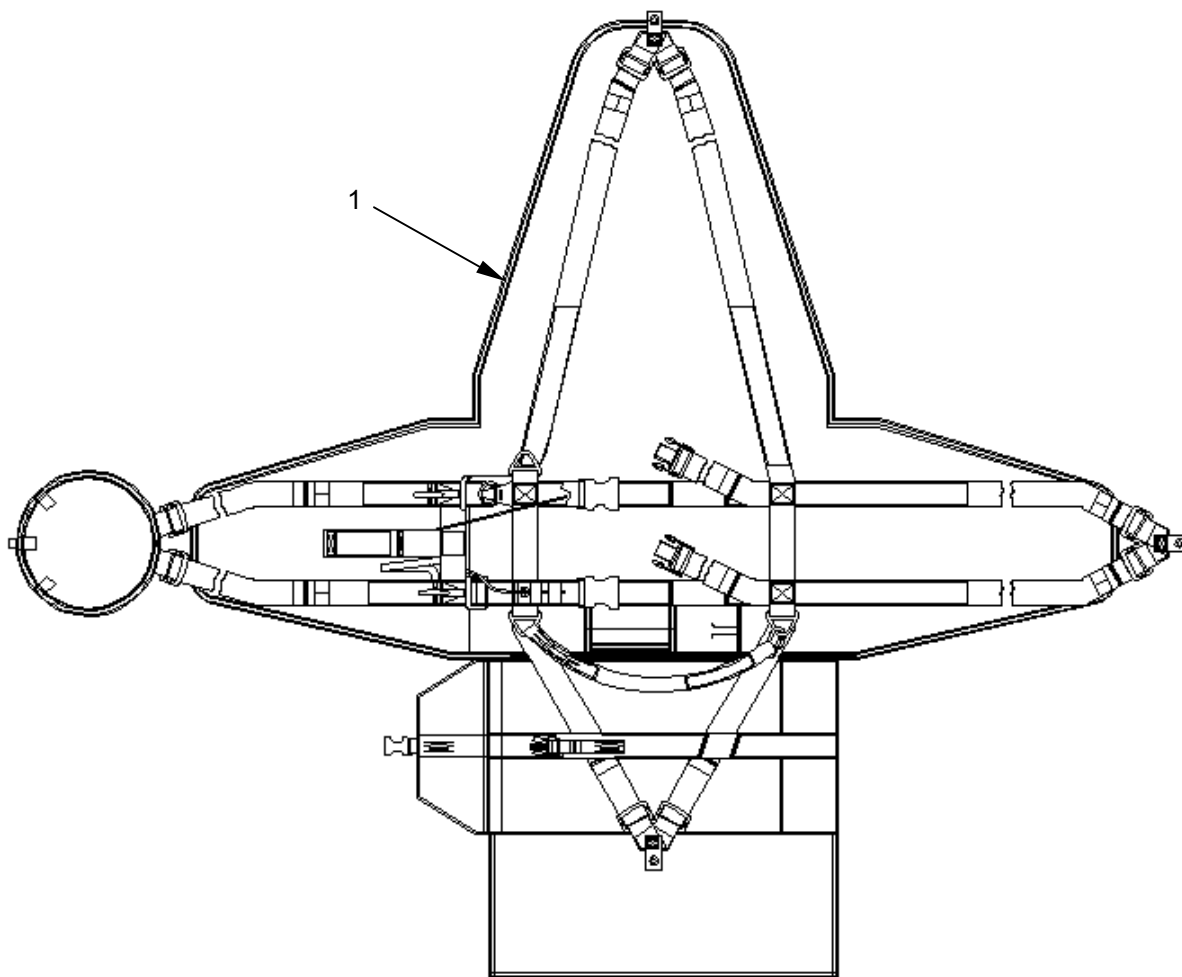
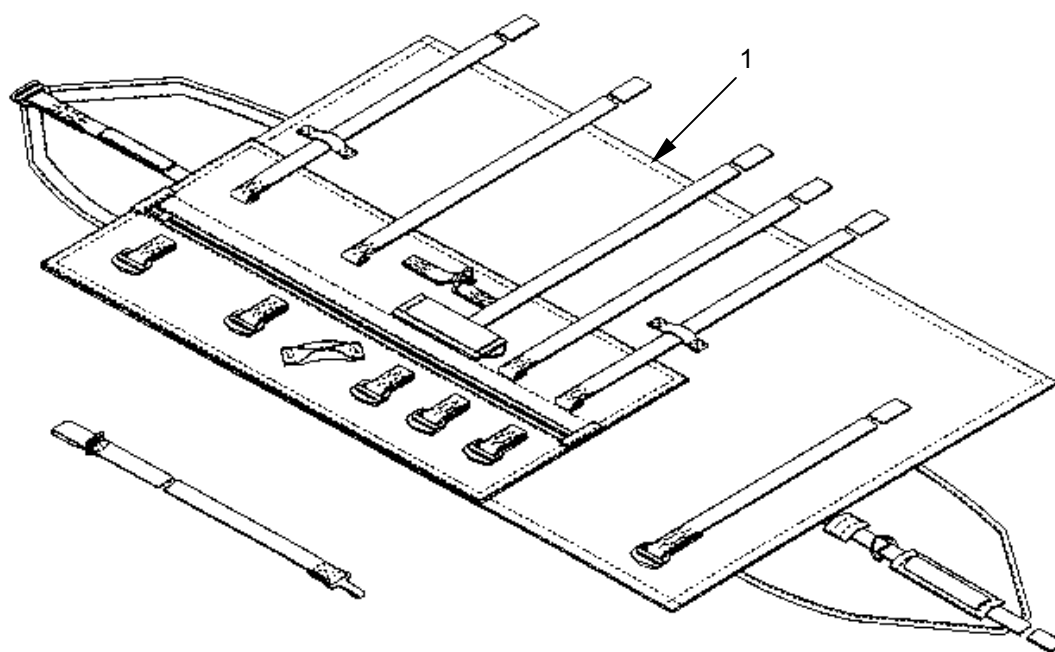

Table 1. Unit Preventive Maintenance Checks and Services-Continued

Item No.	Interval	Location Item to Check/ Service	Procedure	Not Fully Mission Capable If:
13	After	Container, Side Mount (AIRPAC)	Inspect Container, Side Mount (AIRPAC) (1) for loose or broken stitches, or frayed, worn, and cut areas in fabric. Bent, missing or damaged hardware.	Open seams, cuts, tears or frays in fabric. Missing or damaged hardware.



UNIT MAINTENANCE
ANCILLARY EQUIPMENT FOR PERSONNEL PARACHUTE SYSTEM
INTRODUCTION

INTRODUCTION TO UNIT MAINTENANCE

This section contains Unit Maintenance applicable to the Ancillary Equipment For Personnel Parachute Systems as authorized by the Maintenance Allocation Chart (MAC), Work Package 0034 00, of this manual.

All maintenance procedures in this section can be performed by one person unless otherwise indicated. Read all **WARNINGS**, **CAUTIONS**, **NOTES**, and instructions carefully before attempting any procedures. Read and understand all warnings at the front of this manual.

All Unit Maintenance instructions covered in this section are unique to Ancillary Equipment For Personnel Parachute Systems.

REPAIR PARTS; TOOLS; SPECIAL TOOLS; TEST MEASUREMENT AND DIAGNOSTIC EQUIPMENT (TMDE); AND SUPPORT EQUIPMENT

COMMON TOOLS AND EQUIPMENT. For authorized common tools and equipment, refer to the Modified Table of Organization and Equipment (MTOE), CTA 50-970, or CTA 8-100, as applicable to your unit.

SPECIAL TOOL, TMDE, AND SUPPORT EQUIPMENT. The tool and test equipment requirements required for the maintenance of the Ancillary Equipment For Personnel Parachute Systems are listed in WP 0034 00, Tool and Test Equipment List.

REPAIR PARTS. Repair parts for the Ancillary Equipment For Personnel Parachute Systems are listed and illustrated in WP 0035 00, Repair Parts and Special Tools List.

SERVICE UPON RECEIPT OF MATERIEL.

Shipping Materials. Save the shipping cartons and crates for reuse when possible.

Checking Unpacked Equipment. Inspect each unpacked component for damage and completeness, and application of all pertinent Modification Work Orders (MWOs) as follows:

Damage: Check the equipment for damage incurred during shipment. Report any damage on DA Form 2404, Equipment Inspection and Maintenance Worksheet and initiate corrective maintenance procedures in accordance with WP 0008 00 of this manual.

Completeness: Inspect the contents of shipment against the packing slip to see if any items are missing. Report any discrepancies in accordance with DA Pam 738-750. The equipment may be placed in service provided missing items do not affect function or safety of the equipment.

Modifications: Check DA Pam 25-30 to see if there are any MWOs applicable to the equipment you are unpacking. If any MWOs are listed, check DA Form 2408-5, Equipment Modification Record to see if MWOs have been applied to the equipment. The MWO number will be shown near the equipment nomenclature label. If a current MWO is listed in DA Pam 25-30, but there is no evidence that it has been applied to the equipment you are unpacking, note discrepancy on DA Form 2404, Equipment Inspection and Maintenance Worksheet.

END OF WORK PACKAGE

UNIT MAINTENANCE**ANCILLARY EQUIPMENT FOR PERSONNEL PARACHUTE SYSTEM****INSPECTION**

INITIAL SETUP:**Equipment Condition**

Packed.

References

DA PAM 738-751

TB 43-0002-43

DA PAM 738-750

AR 750-1/AR 750-32

Personnel Required

92R(10) Parachute Rigger

GENERAL

This section contains Unit Maintenance procedures for the Ancillary Equipment for Personnel Parachute System as authorized by the Maintenance Allocation Chart (MAC), WP 0034 00 of this manual. Procedures include instructions for inspecting, servicing, repairing and replacing assemblies and subassemblies. All maintenance procedures in this section can be performed by one person unless otherwise stated in the initial setup. Read all **WARNINGS**, **CAUTIONS**, **NOTES** and instructions carefully before attempting a procedure. Read and observe the **WARNINGS** at the front of this manual.

ROUTINE INSPECTION

A routine inspection is a visual check performed to ascertain the serviceability of all visible components of an item that is packed or rigged for use. The inspection will be made on all components that can be inspected without opening the container. Prior to issue, a parachute rigger will administer this inspection. Aerial delivery equipment issued for an air delivery operation and used will receive a routine inspection prior to being placed into ready-for-issue storage.

TECHNICAL/RIGGER-TYPE INSPECTION

A technical/rigger-type inspection is a complete and thorough inspection of an individual airdrop item, including associated parts and components. The following paragraphs outline criteria applicable to accomplishing a technical/rigger-type inspection. It will be performed by a qualified parachute rigger in accordance with AR 750-32.

1. Inspection Intervals.

- a. Upon initial receipt of procured equipment issued to a using unit by a supply source.
- b. Immediately before equipment is packed or rigged for use in airdrop operations.
- c. Before and after repairs or modifications are made.
- d. At any other time as deemed necessary by the airdrop equipment maintenance officer.

2. **Inspection Function Requirement.** Normally, a technical/rigger-type inspection will be performed at a packing, rigging or repair activity. The inspection of initial receipt items will be performed as a separate function from packing or rigging operations. When the inspection is conducted at a packing or rigging activity, the item to be inspected will be placed in proper layout on a packing table or suitable sized floor area. Should a defect or damage be discovered at any point during the inspection, the inspection will be terminated and the applicable item will be processed and forwarded to a repair activity. The repair activity in turn, will conduct a technical/rigger type inspection that will be performed by only those parachute rigger personnel cited in AR 750-32. The repair activity inspection of personnel parachutes will be made on a shadow table. Any defect discovered during a unit level repair activity inspection which exceeds the capability of that activity will require the affected item to be evacuated to a direct support maintenance facility for determination of economic repair and its application, if applicable.

Perform Inspection as follows:

1. **Overall Inspection.** An overall inspection will be made on the Ancillary Equipment for Personnel Parachute Systems to ascertain the following.
 - a. **Log Record/parachute Inspection Data Pocket and Form.** As applicable inspect the assembly log record/ parachute inspection data pocket (as applicable) to insure the Army Parachute Log Record (DA form 3912) or NAVWPNCEN or NAVWPNS CL 13512/11 (Parachute History Record) is enclosed and properly attached. Further, remove the log record from the pocket and evaluate the recorded entries. Inspect and evaluate as follows:

The Army Parachute Log Record, DA Form 3912, and AFTO 391 are history-type maintenance documents that accompany the items through the period of service of the individual assembly. The log record provides a means of recording maintenance actions performed on the items. Normally, a log record is initiated and attached to a convenient point on the item by a using unit. However, if the item is subjected to alteration or modification by a maintenance activity during the interim period from date of manufacture to receipt by a using unit, the log record will be prepared by the activity performing the maintenance function. Once initiated, a log record will be attached to, or contained in a suitable area, until such time as the item is destroyed or rendered unfit for further use or repair. Additionally, should an item that requires a log record, be transferred from one unit to another, the log record for that item will accompany the item in the transfer action. A prepared log record will not be removed or separated from the item except as directed by the local air delivery equipment maintenance activity officer. A log record that is illegible, lost, damaged, soiled, or precludes further entries due to lack of space, will be replaced upon the next inspection, as applicable, with a serviceable item from stock.
 - b. **Assembly completeness.** Ensure the applicable assembly is complete and that no components (or parts) are missing.
 - c. **Operational Adequacy.** Check the item components and parts to ensure proper assembly, which includes attachment and alignment, and that the assembled product functions in the prescribed manner. Further ensure that no stitch formation (or sewn seam) has been omitted.
 - d. **Markings and Paint.** Inspect each assembly and associated components for faded, illegible, obliterated, or missing informational data, identification numbers, and warning marks. Also check for chipped, worn, or peeled paint, as applicable.

- e. **Foreign Material and Stains.** Inspect each assembly and related components for the presence of dirt or similar type foreign material. Also check for evidence of mildew, moisture, oil, grease, pitch, resin, or contamination by salt water.
2. **Detailed Inspection.** In addition to the overall inspection performed in (1) above, a detailed inspection will be performed on the materials that constitute the assembly or component construction using the following criteria, as applicable:
 - a. **Metal.** Inspect for rust, corrosion, dents, bends, breaks, burrs, rough spots, sharp edges, wear, deterioration; damaged, loose, or missing grommets, safety pins, connector snap, eye hook, pack fastener; improper swaging or welding; loss of spring tension; and missing or loose screws.
 - b. **Cloth.** Inspect for breaks, burns, cuts, frays, holes, rips, snags, tears; loose, missing, or broken stitching or tacking; weak spots, wear, or deterioration.
 - c. **Fabric tape, webbing, and cordage.** Inspect for breaks, burns, cuts, frays, holes, snags, tears, incorrect weaving, and sharp edges formed from searing; loose, missing, or broken stitching, tacking, whipping, and weaving; weak spots, wear, and deterioration.
 - d. **Pressure-sensitive (adhesive) tape.** Inspect for burns, holes, cuts, tears, weak spots; looseness and deterioration.
 - e. **Rubber and elastic.** Inspect for burns, cuts, holes, tears, weak spots; loss of elasticity and deterioration.
 - f. **Felt.** Inspect for cuts, tears, burns, breaks, holes, and thin spots.
 - g. **Leather.** Inspect for burns, cuts, holes, tears, loose missing or broken stitching; thin spots and deterioration.

IN STORAGE INSPECTION

An in-storage inspection is a physical check conducted on a random sample of air delivery equipment that is located in storage. The purpose of the inspection is to ensure that the item is ready for issue, that the item is properly identified and segregated from other types of equipment, that no damage or deterioration of the equipment has been incurred, and that all modifications or similar action requirements have been completed. The inspection shall also concern the methods and procedures applied to the storage of air delivery items, the adequacy of storage facilities, efforts of pest and rodent control, and protection against unfavorable climatic conditions. Air delivery equipment that is in storage will be inspected at least semiannually and at more frequent intervals if prescribed by the local parachute maintenance officer. The frequency of inspection may vary according to the type of storage facilities and local climatic conditions. Only parachute rigger personnel designated by the local parachute maintenance officer will conduct in-storage inspections.

Equipment Disposition

Air delivery equipment may be rendered unserviceable by either normal fair wear or by aging, and will subsequently be repaired, modified, or condemned, as appropriate. Equipment that is uneconomically repairable (outdated) will be condemned. Disposition of air delivery equipment that is condemned, unserviceable, or for which serviceability is questionable, will be accomplished using the following procedures as applicable:

1. **Item requiring repair or modification.** An air delivery item that requires repair or modification will be tagged in accordance with DA Pam 738-751. Subsequent work will be performed on the item at the

maintenance level specified for the maintenance function in the applicable supporting technical publication.

2. **Equipment with exhausted age or service life.** Any component or air delivery equipment whose age or service life has expired as specified in TB 43-0002-43 will be removed from service, condemned and tagged as prescribed by DA PAM 738-751.
3. **Disposition of Condemned Air Delivery Equipment.** Condemned equipment, other than fatality parachutes, will be removed from service and disposed of in accordance with current directives listed in this WP.
4. **Rejected equipment.** Equipment which, prior to use is deemed unserviceable will be reported in an Equipment Improvement Recommendation (EIR) in accordance with DA PAM 738-750, as authorized by AR 750-1. Each applicable item that is defective will be held and safeguarded pending receipt of disposition instructions from the National Maintenance Point (NMP). In all instances, EIR exhibit material will be handled as prescribed in DA PAM 738-750. If the quality or the serviceability of an item is questionable, clarification and assistance may be obtained by contacting Commander, U.S. Army Soldier and Biological Chemical Command, ATTN: AMSSB-RIM-E(N), Kansas Street, Natick, MA 01760-5052.
5. **Equipment of Doubtful Serviceability.** Equipment that has had previous use and has not exceeded normal fair wear or aging criteria, but of which further serviceability is doubtful, will be tagged as prescribed in DA PAM 750-751. In addition, the equipment will be reported in an EIR, in accordance with DA PAM 738-750 and AR 750-1. The item(s) in question will be held as EIR exhibit material as outlined in DA PAM 738-750 pending receipt of disposition instructions from the NMP. A maintenance activity holding EIR exhibit material will not tamper with the applicable item(s) or make any attempt to ascertain cause factors. Unnecessary handling of EIR exhibit material may disturb or alter peculiar aspects of the affected item(s) that might affect the judgment of engineering personnel who have the responsibility for final evaluation of EIR actions.
6. **Equipment immersed in salt-water.** Any air delivery item constructed from cotton material that has been immersed in salt-water will be condemned. Cotton thread used for tacking and sewing on nylon that has been immersed in salt-water will only be replaced when there is visible evidence or deterioration such as extreme discoloration or indications of broken thread. Any air delivery equipment constructed of nylon or rayon material that has been immersed in salt-water for a period less than 24-hours, but which cannot be rinsed within 48-hours after recovery will also be condemned unless the following actions can be performed. Upon removal from the salt water, the parachute is placed in a single heavy duty plastic trash bag, the top of the bag securely closed and kept in a wet state until a rinse can be performed following normal rinse procedures. The bag must be doubled when outside temperatures exceed 85 degrees F. The bags must be inspected after transport and storage to insure the bag did not get torn and the assembly allowed to dry. Parachutes recovered using this method must be rinsed no later than 7 days after the salt water immersion or be condemned. However, if the cited time limitations can be met, then immediately upon recovery, suspend or elevate the recovered equipment in a shaded area and allow the item(s) to drain for at least 5-minutes. Do not attempt to wring the equipment fabric. Within 48-hours after recovery, under the supervision of a qualified parachute rigger (92R), rinse the recovered equipment as indicated in WP 0009 00.

END OF WORK PACKAGE

UNIT MAINTENANCE

ANCILLARY EQUIPMENT FOR PERSONNEL PARACHUTE SYSTEM

CLEANING AND DRYING

INITIAL SETUP:**Tools**

N/A

Personnel Required

92R(10) Parachute Rigger

Materials/Parts

Brush, Scrub Household (WP 0052 00, Table 1, Item 2)

Cloth, Abrasive (WP 0052 00, Table 1, Item 4)

Dishwashing Compound (WP 0052 00, Table 1, Item 15)

Rag, Wiping (WP 0052 00, Table 1, Item 27)

Equipment Condition

Laid out on packing table or other suitable surface.

CAUTION

If, during the cleaning, there exists a possibility that the substance to be removed contains acid or some other equally destructive ingredient, the item will be evacuated to intermediate maintenance activity for determination as to the nature of the substance and item disposition. If the substance cannot be identified, or if normal repair procedures will not eliminate all traces of chemical or acid damage, the applicable item will be condemned.

NOTE

Cleaning of fabric items should be held to a minimum and should be performed only when necessary, to prevent malfunction or deterioration. When fabric item(s) contains debris, or when it is soiled by dirt, oil, grease, rust, corrosion, or other foreign substances, to such an extent that cleaning is necessary, the cleaning should be performed manually and should be limited to the soiled area only, unless the fabric items has been contaminated by water. The methods of cleaning must be determined by the nature of the substance to be removed. Do not use cleaning solvent to clean items soiled by airsickness. Use a solution of hand dishwashing compound to clean this type of soiling.

CLEANING FABRIC ITEMS WITH A SOLUTION OF HAND DISHWASHING COMPOUND

Use dishwashing compound to clean fabric items as follows:

1. Gently brush with a soft bristle brush.
2. Spot clean with a solution of dishwashing compound.
 - a. Dissolve one-half cup of dishwashing compound in one-gallon of warm water.
 - b. Rub the soiled area with a clean cloth dampened with a solution of dishwashing compound.

- c. Rinse the cleaned area by repeating the rubbing process, with a clean portion of the cloth dampened with water.

RINSING FABRIC ITEMS IMMERSSED IN SALT WATER

If the fabric items, or any of its components, has been immersed in salt water in excess of 24-hours it will be condemned. Additionally, if the fabric items, or any of its components, has been immersed in salt water for a period less than 24-hours, but cannot be rinsed within 48-hours after recovery, it will also be condemned unless the following actions can be performed. Upon removal from the salt water, the parachute is placed in a single heavy duty plastic trash bag, the top of the bag securely closed and kept in a wet state until a rinse can be performed following normal rinse procedures. The bag must be doubled when outside temperatures exceed 85 degrees F. The bags must be inspected after transport and storage to insure the bag did not get torn and the assembly allowed to dry. Parachutes recovered using this method must be rinsed no later than 7 days after the salt water immersion or be condemned. However, if the cited time limitations can be met, then immediately upon recover, suspend or elevate the fabric item assembly in a shaded area and allow it to drain for at least 5-minutes. Do not attempt to wring the fabric. Within 48-hours after recovery, under the supervision of a qualified parachute rigger (92R), rinse the recovered fabric item assembly as follows:

1. Place the fabric items in a large watertight container filled with a suitable amount of fresh, clean water to cover the assembly.

NOTE

If the salt-water-soaked fabric item is too large to be placed into a rinsing container, then the rinsing process will be affected by applying fresh, clean water to the assembly using a hose.

2. Agitate the container contents by hand for 5-minutes.
3. Remove the fabric item from the container and suspend or elevate it in a shaded area, allowing a 5-minute drainage period. Do not attempt to wring the fabric.
4. Repeat the procedures in steps 1. through 3. above, twice, using fresh, clean water for each rinse.
5. After the third rinse, allow the fabric item to drain thoroughly. Upon completion of draining, dry the assembly in accordance with the DRYING FABRIC ITEMS procedures, below.
6. When dried, perform a technical/rigger-type inspection of the fabric items. Corroded metal components, or corrosion-stained fabrics, will be either repaired or replaced as prescribed by the Maintenance Allocation Chart (MAC) in WP 0034 00.
7. Record any repair, immersion, and rinsing in the parachute log record as shown in WP 0004 00.

RINSING FABRIC ITEMS IMMERSSED IN FRESH WATER

Any fabric item, or its components, that has been immersed in a fresh water lake, river, or stream will not require rinsing unless it has been ascertained that the water is dirty, oily, or otherwise contaminated. Procedures for handling a fresh water immersed fabric item are as follows:

1. **Contaminated freshwater.** If the fabric item, or its components, has been immersed in contaminated freshwater, rinse and dry (see RINSING FABRIC ITEMS IMMERSSED IN SALT WATER, above), and, if applicable, repair.
2. **Uncontaminated freshwater.** If the fabric item, or its components, has been immersed in uncontaminated freshwater, it will be cleaned and dried as outlined in CLEANING FABRIC ITEMS WITH A SOLUTION OF HAND DISHWASHING COMPOUND, DRYING FABRIC ITEMS, and CLEANING METAL ITEMS, in the detailed paragraphs above and below. Minor discoloration of fabric items, resulting from immersion in uncontaminated fresh-water, may occur.

NOTE

Fabric items will not be dried in direct sunlight or by laying an item on the ground.

DRYING FABRIC ITEMS

Dry fabric items as follows:

1. Suspend or elevate the item in a well-ventilated room or in a heated drying room.
2. Using electric circulating fans may reduce drying time.
3. When heat is used, the heat temperature shall not exceed 160 degrees Fahrenheit (71 degrees Celsius). The preferred temperature is 140 degrees Fahrenheit (60 degrees Celsius).

CLEANING METAL ITEMS

Clean metal items as follows:

CAUTION

Use care not to damage the adjacent fabric materials.

1. Remove burrs, rough spots, rust, or corrosion from metal items by filing with a metal file, or by buffing and polishing with abrasive cloth.
2. Remove all oils and filings by brushing and cleansing with dishwashing compound. Allow to dry.

END OF WORK PACKAGE

ANCILLARY EQUIPMENT FOR PERSONNEL PARACHUTE SYSTEM

AIRING

INITIAL SETUP:

Tools

N/A

Personnel Required

92R(10) Parachute Rigger

Materials/Parts

N/A

AIRING

Where dampness and mildew are prevalent, air delivery equipment will be aired at frequent intervals according to the severity of the prevailing conditions. Items that have been previously packaged or are unpackaged, and have been subjected to conditions of dampness or mildew, will be aired for a period of at least 6-hours prior to being repackaged. Air delivery items may be aired either indoors or outdoors, in dry weather. However, fabric items will not be aired in direct sunlight. Suspending or elevating the applicable item(s) in a manner that would allow maximum exposure to air circulation may accomplish airing. Outside facilities may be used for the airing of air delivery equipment if weather conditions permit. If the shakeout facilities are inadequate for airing, the applicable item(s) may be suspended or elevate at several points, or draped over suitable type objects that will not cause damage.

END OF WORK PACKAGE

UNIT MAINTENANCE

ANCILLARY EQUIPMENT FOR PERSONNEL PARACHUTE SYSTEM

SALT/FRESH-WATER CONTAMINATION TEST

INITIAL SETUP:**Tools**

N/A

Personnel Required

92R(10) Parachute Rigger

Materials/Parts

N/A

Equipment Condition

Laid out on packing table or other suitable area.

INSPECTION

Look for a white crystalline residue. If evidence of salt-water/fresh-water contamination is found, refer to the procedures detailed below:

RINSING FABRIC ITEMS IMMERSSED IN SALT-WATER. If the fabric items, or any of its components, has been immersed in salt water in excess of 24-hours it will be condemned. Additionally, if the fabric items, or any of its components, has been immersed in salt water for a period less than 24-hours, but cannot be rinsed within 48-hours after recovery, it will also be condemned unless the following actions can be performed. Upon removal from the salt water, the parachute is placed in a single heavy duty plastic trash bag, the top of the bag securely closed and kept in a wet state until a rinse can be performed following normal rinse procedures. The bag must be doubled when outside temperatures exceed 85 degrees F. The bags must be inspected after transport and storage to insure the bag did not get torn and the assembly allowed to dry. Parachutes recovered using this method must be rinsed no later than 7 days after the salt water immersion or be condemned. However, if the cited time limitations can be met, then immediately upon recover, suspend or elevate the fabric item assembly in a shaded area and allow it to drain for at least 5-minutes. Do not attempt to wring the fabric. Within 48-hours after recovery, under the supervision of a qualified parachute rigger (92R), rinse the recovered fabric item assembly as follows:

1. Place the fabric items in a large watertight container filled with a suitable amount of fresh, clean water to cover the assembly.

NOTE

If the salt-water-soaked fabric item is too large to be placed into a rinsing container, then the rinsing process will be affected by applying fresh, clean water to the assembly using a hose.

2. Agitate the container contents by hand for 5-minutes.
3. Remove the fabric item from the container and suspend or elevate it in a shaded area, allowing a 5-minute drainage period. Do not attempt to wring the fabric.
4. Repeat the procedures in steps 1. through 3., above, twice, using fresh, clean water for each rinse.
5. After the third rinse, allow the fabric items to drain thoroughly. Upon completion of draining, dry the assembly in accordance with the DRYING FABRIC ITEMS procedures detailed below.

6. When dried, perform a technical/rigger-type inspection of the fabric items. Corroded metal components, or corrosion-stained fabrics, will be either repaired or replaced as prescribed by the Maintenance Allocation Chart (MAC) in WP 0034 00.
7. Record any repair, immersion, and rinsing in the parachute log record as shown in WP 0004 00.

RINSING FABRIC ITEMS IMMERSSED IN FRESH-WATER. Any item, or its components, that has been immersed in a fresh water lake, river, or stream will not require rinsing unless it has been ascertained that the water is dirty, oily, or otherwise contaminated. Procedures for handling fresh water immersed fabric items are as follows:

1. Contaminated fresh water. If the fabric item, or its components, has been immersed in contaminated fresh water, rinse and dry (see RINSING FABRIC ITEMS IMMERSSED IN SALT WATER, ABOVE), and, if applicable, repair.
2. Uncontaminated fresh water. If the fabric item, or its components, has been immersed in uncontaminated fresh water, it will be cleaned and dried as outlined in CLEANING FABRIC ITEMS WITH A SOLUTION OF HAND DISHWASHING COMPOUND, DRYING FABRIC ITEMS, AND CLEANING METAL ITEMS, in the detailed paragraphs above and below. Minor discoloration of fabric items, resulting from immersion in uncontaminated fresh water, may occur.

NOTE

Fabric items will not be dried in direct sunlight or by laying an item on the ground.

DRYING FABRIC ITEMS. Dry fabric items as follows:

1. Suspend or elevate the item in a well-ventilated room or in a heated drying room.
2. Using electric circulating fans may reduce drying time.
3. When heat is used, the heat temperature shall not exceed 160 degrees Fahrenheit (71 degrees Celsius). The preferred temperature is 140 degrees Fahrenheit (60 degrees Celsius).

END OF WORK PACKAGE

UNIT MAINTENANCE

ANCILLARY EQUIPMENT FOR PERSONNEL PARACHUTE SYSTEM

SEWING PROCEDURES

INITIAL SETUP:**Tools**

Specified in paragraph applicable to the item being repaired.

Personnel Required

92R(10) Parachute Rigger

Materials/Parts

Specified in paragraph applicable to the item being repaired.

Equipment Condition

Unpacked. Canopy with defects recorded.
Clean.

References

WP 0032 00

REPAIR**NOTE**

Sewing requirements will vary according to the type of item being repaired and the type of repair being made. The type of sewing machine, type of thread, the stitch range, and the stitch pattern (if applicable) required to accomplish a sewing procedure will be specified in the paragraph applicable to the item being repaired. All original stitching that is cut during the performance of a sewing procedure will be removed from the applicable item. Immediately after the accomplishment of a machine sewing procedure, trim thread ends to a point as close as possible to the material that has been sewn.

NOTE

Repair and replacement of ancillary equipment is performed in accordance with the repair instruction in this section and in specific paragraphs applicable to the item being repaired. Fabrication is a means of replacing an air delivery item component that is damaged beyond repair and not an issue item. Though the act of fabrication is a replacement-type action, the function is actually a method of repairing an end item. Since most fabrication pertains to components that are peculiar to ancillary equipment, the fabrication of components that are most general in nature will be detailed in the following paragraphs.

BASTING AND TEMPORARY TACKING

Basting and temporary tacking are hand-sewing methods used to temporarily hold layers of cloth fabric together while a repair is being performed. The following is a list of procedures that apply to basting and temporary tacking actions:

1. Basting and temporary tacking should be made using thread that is of a contrasting color to the material being worked.
2. Basting and temporary tacking will be performed using a single strand of size A, nylon thread, or ticket No. 24/4 cotton thread.
3. When basting, do not tie knots at any point in the thread length. Also, the sewing should be made with two stitches per inch.
4. Immediately upon completion of a repair, remove previously made basting or temporary tacking.

STITCHING AND RESTITCHING

Perform stitching and restitching as follows, refer to Tables 1 and 2.

1. The stitching and restitching of ancillary equipment should be accomplished with thread that is contrasting in color to the fabric being restitched. If contrasting color thread is not available, thread of matching color may be used, providing all other specifications are met. Straight stitching and restitching on parachute canopy assemblies should be locked by at least $\frac{1}{2}$ -inch at each end of a stitch row, when possible. Zig-Zag stitching does not require locking; however, zig-zag restitching should extend at least $\frac{1}{2}$ -inch into undamaged stitching at each end, when possible. Keep proper thread tension when possible to prevent loose bobbin thread, and excessively tight stitching resulting in puckering of the materials sewn. The stitching lock should be embedded in the center of the material. When restitching, stitch directly over the original stitching and follow the original stitch pattern as closely as possible.

Table 1. Sewing Machine Code Symbols

CODE SYMBOL	SEWING MACHINE
LD	SEWING MACHINE, INDUSTRIAL: General Sewing; 301 Stitch; Light Duty; NSN 3530-01-177-8590.
MD ZZ	SEWING MACHINE, INDUSTRIAL: Zig-Zag; 308 Stitch; Medium Duty; NSN 3530-01-181-1421.
LD ZZ	SEWING MACHINE, INDUSTRIAL: Zig-Zag; 308 Stitch; Light Duty; NSN 3530-01-181-1420.
HD	SEWING MACHINE, INDUSTRIAL: General Sewing; 301 Stitch; Heavy Duty; NSN 3530-01-177-8588.
MD	SEWING MACHINE, INDUSTRIAL: General Sewing; 301 Stitch; Medium Duty; NSN 3530-01-177-8591.
DN	SEWING MACHINE, INDUSTRIAL: Darning; Lock Stitch; NSN 3530-01-177-8589
LHD	SEWING MACHINE, INDUSTRIAL: 301 Stitch; Light-Heavy Duty; NSN 3530-01-186-3079.
ND	SEWING MACHINE, INDUSTRIAL: 301 Stitch; Double-Needle; NSN 3530-01-182-2873.

Table 2. Stitching and Restitching Specifications

COMPONENT	RECOMMENDED SEWING MACHINE (CODE SYMBOL)	STITCHES PER INCH	THREAD SIZE
Extension, Static Line Assembly	HD	4 to 6	6
SCUBA Set, Accessory			
96-Inch Harness Backstrap	HD	4 to 6	6
Support Strap	HD	5 to 8	3
Waistband Extension Strap	LD	7 to 11	E
Lowering Line, General	LD	7 to 11	E
Snap hook	HD	5 to 8	3
Attaching Web	LD	7 to 11	E
Jump Pack, DRAGON Missile	HD	5 to 8	3
Darning	DN	Darn	E
Tack Felt Plug	HD	5 to 8	3
Lowering Line	LD	7 to 11	E
Harness, Single Point Release			
Harness, Stitching	HD	5 to 8	3
Attaching Harness Strap	HD	5 to 8	3
Darning	DN/ZZ	Darn	E
Splicing	MD	Darn	E
Loops "A", "B", "C"	ZZ/MD	7 to 10/6 to 9	E/FF
Lanyard	HD	5 to 8	3
Retainer Loop			
Attachment to Release Assembly	MD	6 to 9	FF
Elastic Keeper			
Keeper Assembly	MD	6 to 9	FF
Attachment to Release Assembly	MD	6 to 9	FF
Attachment of Hook & Pile Tapes	MD	6 to 9	FF
Jump Pack AT4:			
Pack Body Patching	HD	6 to 9/5 to 8	FF/3
Darning	DN or ZZ	Darn	E/FF
Plugging Felt	HD	5 to 8	3
Binding Tape	HD	6 to 9/5 to 8	FF/3
Rifle Butt or Muzzle Pockets	HD	6 to 9/5 to 8	FF/3
Lowering Line Pocket			
Pocket Assembly	MD	6 to 9	FF
Hook and Pile Assembly	MD	6 to 9	FF
Attachment to Pack	HD	5 to 8	3
Case, Parachutist's Individual Weapon M1950 (Nylon)			
General Stitching	HD/MD	4 to 6/6 to 9	5/FF
Lowering Line Pocket	HD	4 to 6	5
Felt Padding	HD	5 to 8	3
Sides and Ends of Case	HD	4 to 6	5
Webbing Reinforcement	HD	4 to 6	5
Corner Reinforcement	HD	5 to 8	3
Tiedown Loops	HD	5 to 8	3
Buckle Loop	HD	5 to 8	3
Shock Absorber Loop	HD	5 to 8	3

Table 2. Stitching and Restitching Specifications (Continued)

COMPONENT	RECOMMENDED SEWING MACHINE (CODE SYMBOL)	STITCHES PER INCH	THREAD SIZE
Flap Thong	MD	6 to 9	FF
Slide Fastener Thong	MD	6 to 9	FF
Slide Fastener Tape	MD	5 to 8	3
Loop Chape	HD	4 to 6	5
Adjusting Strap	HD	4 to 6	5
Release Assembly, Loop Chape	HD	4 to 6	5
Parachutist's Weapons and Individual Equipment Harness			
General Restitching	MD	7 to 11	E
Lowering Line Pocket	HD	5 to 8	3
General Darning	DN/ZZ	Darning	E
Darning Long Narrow Cuts	ZZ	Darning	E
Lowering Line Pocket Flap	MD	6 to 9	FF
Lowering Line Pocket Tie	MD	6 to 9	FF
Splicing Webbing	HD	5 to 8	3
Replace Webbing	HD	5 to 8	3
Keeper Pin Strap	LD	7 to 11	E
Jump Pack Stinger Missile Pack, Body, Patching	HD	6 to 9	FF
Darning	DN or ZZ	7 to 11	E
Plugging Felt	HD	6 to 9	FF
Binding Tape	HD	6 to 9	FF
Carrying Handle Strap			
Handle Assembly	MD	6 to 9	FF
Attachment to Pack	HD	5 to 8	3
O-Ring Chape	HD	4 to 6	5
Securing Straps			
Side	HD	5 to 8	3
Aft and Forward	HD	4 to 6	5
Hook and Pile Fastener			
To Pack	HD	6 to 9	FF
To Webbing	MD	6 to 9	FF
Lowering Line			
Darning	DN or ZZ	7 to 11	E
Binding Tape	LD	7 to 11	E
Hook and Pile Fastener	LD	7 to 11	E
Retainer Assembly	LD	7 to 11	E
Loop Quick Fit Assembly	HD	5 to 8	3
Tiedown Assemblies			
Chape to Pack	HD	5 to 8	3
Tiedown Straps	MD	7 to 11	E
Extension Sling	MD	5 to 8	3
Cable Guide Assembly			
Guide to webbing	MD	6 to 9	FF
Assembly to Pack	HD	5 to 8	3

Table 2. Stitching and Restitching Specifications (Continued)

COMPONENT	RECOMMENDED SEWING MACHINE (CODE SYMBOL)	STITCHES PER INCH	THREAD SIZE
Drop Bag Parachute Pack Body Patching Darning Binding Tape Elastic Keeper Attachment, Hook, Pile, Tape Carrying Handle Strap Handle Assembly Attachment to Pack Link/D-Ring Chape Securing Straps Cross Straps WebChapes Lowering Line Darning BindingTape Hook and Pile Assembly Retainer Assembly Loop/Quick Fit Assembly	MD DN/FF LD LD LD MD HD HD HD HD HD DN or ZZ LD LD LD HD	6 to 9 Darn 7 to 11 7 to 11 7 to 11 5 to 8 5 to 8 5 to 8 5 to 8 5 to 8 5 to 8 7 to 11 7 to 11 7 to 11 7 to 11 5 to 8	FF E E E E FF 3 3 3 3 3 E E E E 3
Case, Parachutist's Individual Weapon M1950 (Cotton) General Stitching Lowering Line Pocket Felt Padding Sides and Ends of Case Leather Reinforcement Strip Panel Corner Reinforcement Tiedown Loops Buckle Loop Shock Absorber Loop Flap Thong Slide Fastener Thong Slide Fastener Tape Loop Chape Adjusting Strap Triangular Loop Chape Single Loop Chape	HD HD HD HD HD HD HD HD HD HD MD MD MD HD HD HD HD	4 to 6 5 to 8 5 to 8 4 to 6 4 to 6 5 to 8 5 to 8 5 to 8 5 to 8 5 to 8 5 to 8 6 to 9 6 to 9 6 to 9 4 to 6 4 to 6 4 to 6 4 to 6	5 3 3 5 5 3 3 3 3 3 3 FF FF FF 5 5 5 5
Parachutist's Weapons and Individual Equipment Pack General Patching Center Webbing Darning Vertical Straps Compression Strap	MD MD DN/ZZ MD HD/MD	6 to 9 6 to 9 Darning 5 to 8 4 to 6/6 to 9	FF FF E 3 5/FF

Table 2. Stitching and Restitching Specifications (Continued)

COMPONENT	RECOMMENDED SEWING MACHINE (CODE SYMBOL)	STITCHES PER INCH	THREAD SIZE
Lowering Line Assembly	MD	4 to 6/6 to 9	5/FF
Attaching Straps	MD	4 to 6/6 to 9	5/FF
Breakaway Leg Straps	MD	4 to 6/6 to 9	5/FF
Quick Release Assembly			
550 Cord to Lanyard	HD	6 to 9	FF
Lanyard to Handle	HD	6 to 9	FF
Webbing Handle	Hand Tack		

DARNING

(Refer to Tables 1 and 2). Darning is a sewing procedure used to repair limited size holes, rips, and tears. A darning repair may be made either by hand or by sewing machine, depending upon the method preferred and the availability of equipment. However, a darning machine should be used to darn small holes and tears where fabric is missing. A darning repair will be preformed using the following procedures, as appropriate:

Machine darning. Proceed as follows:

1. Using an authorized marking aid of contrasting color, mark a square around the damaged area and ensure the marking is at least 1/4 inch back from each edge of the damaged area.
2. Darn the damaged area by sewing the material in a back and forth manner, using size A or E nylon thread.
3. Turn the material and stitch back and forth across the stitching made in b., above, until the hole or tear is completely darned.

BACK AND FORTH STITCHING IN BOTH DIRECTIONS

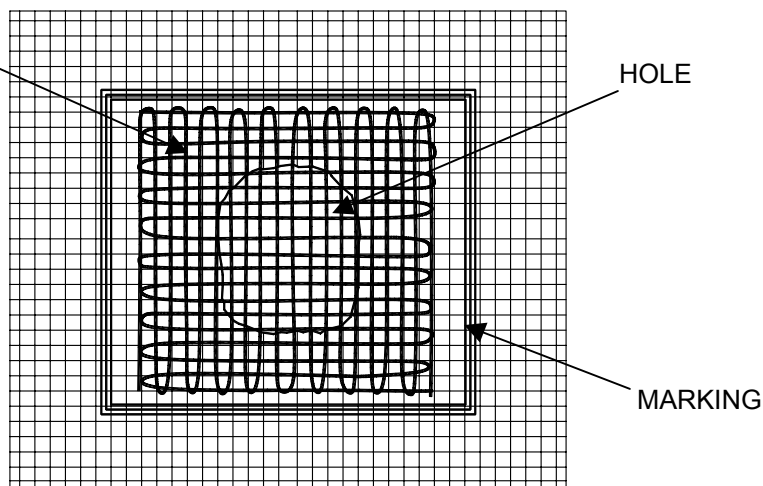

4. If applicable, restencil informational data, or identification marks using the criteria in WP 0014 00.

Hand darning. When repair of a hole or tear is made by hand darning, the darn should match the original weave of the damaged material as closely as possible. Hand darning will be performed as follows:

1. Using an authorized marking aid of contrasting color, mark a square around the damaged area and ensure the marking is at least ¼ -inch back from each edge of the damaged area.
2. Using a darning needle and a length of size A or E nylon thread, begin darning at one corner of the marked area. Working parallel with the marking, pass the needle and thread back and forth through the material until the opposite diagonal corner of the marked area is reached.
3. Turn the material and weave the needle and thread back and forth across the stitching made in b., above, until the hole is completely darned.

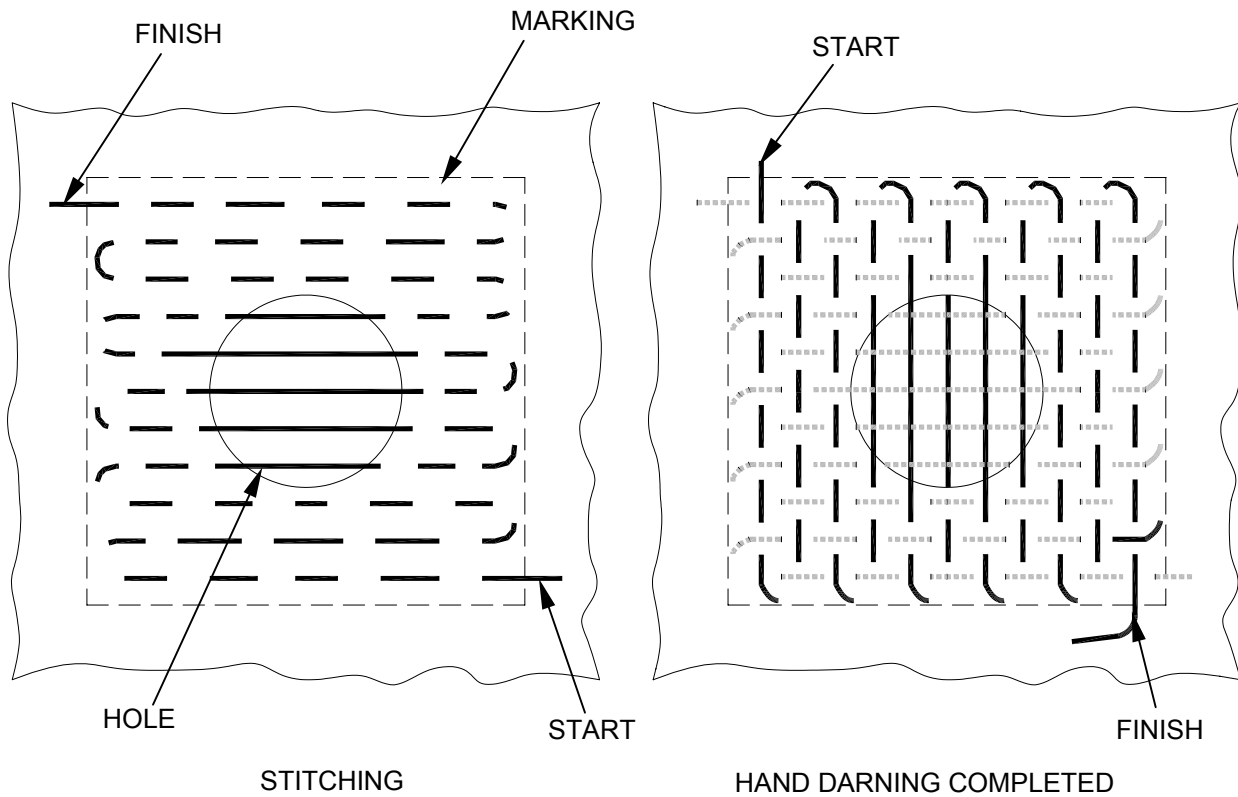

4. If applicable, restencil informational data or identification marks as outlined in WP 0014 00.

ZIG-ZAG SEWING

(Refer to Tables 1 and 2). Ancillary Equipment for Parachute Systems, that have sustained cut or tear damage, may be repaired by zig-zag sewing, provided the applicable damaged area does not have any material missing and the cut or tear is straight or L-shaped. Should the damaged area be irregular shaped or have material missing, the repair will be achieved by either darning or patching, as required. A zig-zag sewing repair will be accomplished using a zig-zag sewing machine, with the following procedures:

1. Set the sewing machine to the maximum stitch width.
2. Beginning at a point $\frac{1}{4}$ -inch beyond one end of the cut or tear, stitch lengthwise along the damaged area to a point $\frac{1}{4}$ -inch beyond the opposite end of the cut or tear.

**Straight Cut Or Tear Stitching**

3. The cited stitching procedure will also apply to an L-shaped cut or tear.

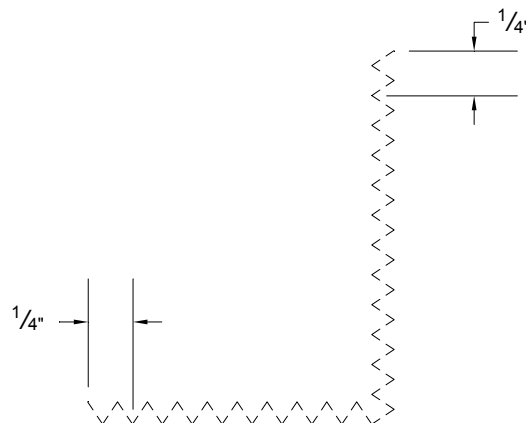
**L-Shaped Cut Or Tear Stitching**

4. If applicable, restencil informational data or identification marks as prescribed in WP 0014 00.

PATCHING

Patching is a procedure used to repair holes that cannot be darned.

Patching limitations. The following is a list of patching limitations for Ancillary Equipment for Personnel Parachute System:

WARNING

The limitations prescribed for patching will be stringently adhered to under all circumstances and without any deviations. Failure to do so may result in failure of an ancillary item causing death or serious injury to personnel.

1. A patch will not be applied to a damaged area that has been previously patched.
2. There is no limitation to the number of patches, or size of patch, made to each area. However, determination should be made as to the most economical method to be used, i.e., two or more patches versus one large patch, or damage that would require replacement.

Making a basic patch. A basic patch is used to repair damaged cloth when the affected area is no closer than 1-inch from a seam. Should a damaged area be closer than 1-inch to the cited areas, a miscellaneous patch will be made as detailed in paragraph 3., below. There are three methods that may be used to apply a basic patch; the procedures for performing each method are outline in paragraphs a. and b., as follows:

NOTE

A basic patch will be square or rectangular in shape.

The sewn patch. The primary method of applying a basic patch is by sewing. When using this method of patching, the patch will be applied to either the inside or the outside.

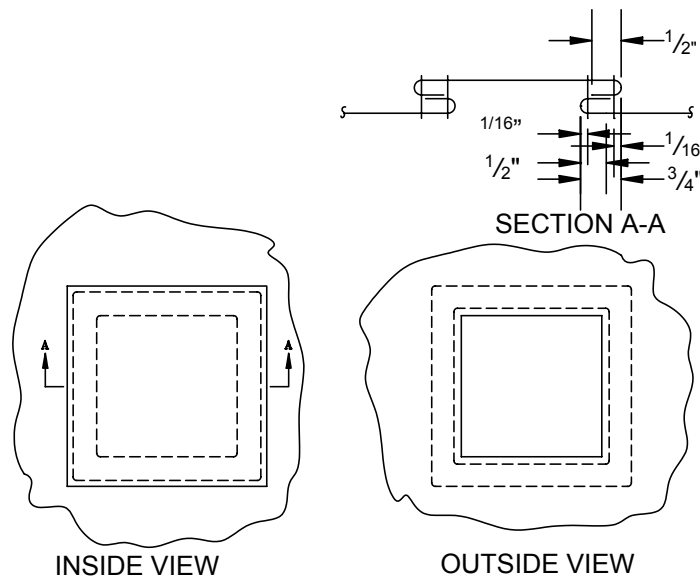

Apply a sewn patch as follows:

1. Place the repairable item on a repair table, smooth the fabric around the damaged area, and secure the item to the table with pushpins. Do not pin the damaged area.
2. Using an authorized marking aid of contrasting color, mark a square or rectangle around the area to be patched.
3. Cut the damaged fabric area along the lines made in 2., above. Further, cut the fabric diagonally at each corner to allow a 1/2 -inch foldback in the raw edges.

4. Make a ½ -inch foldback on each raw edge. Pin and baste each foldback to complete the prepared hole. Basting will be performed using the procedures in the BASTING AND TEMPORARY TACKING paragraph detailed above.
5. Using the same type of material as in the original construction, mark and cut a patch 2 ½ -inches wider and longer than the inside measurements of the prepared hole.
6. Center the material over the prepared hole. Pin the patch material in position.
7. Make a ½ -inch foldunder on each edge of the patch material, and baste the patch to the prepared area. Basting will be performed using the procedures in the BASTING AND TEMPORARY TACKING paragraph detailed above.
8. Remove the pushpins securing the canopy to the repair table; secure the patch by stitching, using the applicable details in the STITCHING AND RESTITCHING paragraph and figure detailed above. Make the first row of stitching completely around the patch. Turn the canopy over and make a second row of stitching around the prepared hole. Stitching will be performed in accordance with the STITCHING AND RESTITCHING paragraph detailed above.
9. If applicable, restencil informational data according to procedures in WP 0014 00.

Applying a miscellaneous patch. A miscellaneous patch, which may be irregularly shaped, is used to repair damaged material when the location of the damaged area requires the patch to extend into (or over) a seam or reinforcement. Ascertain the type of patch required for the item, using the details in illustrations following the patch procedures detailed below. Apply a miscellaneous patch as follows:

NOTE

A section that cannot be patched with a basic patch, as outlined in paragraph 2., above, will be patched with a miscellaneous patch.

1. Place the item on a repair table; smooth the fabric around the damaged area, and secure the damaged area to the table with pushpins. Do not pin the damaged area.
2. As required, cut the applicable stitching to remove or lay aside items that may interfere with the patching process.
3. Using an authorized marking aid of contrasting color, mark a rectangle or triangle around the damaged area. Make the mark ½ -inch from any adjacent seam or reinforcement.
4. Prepare the damaged area by cutting along the marks made in c., above. Also make a diagonal cut at each corner of the formed hole to permit a foldback of each raw edge.
5. To complete hole preparation, make a ½ -inch foldback of each raw edge. Pin and baste each edge foldback; use the procedures in the BASTING AND TEMPORARY TACKING paragraph detailed above.
6. Using the same type of material as in the original construction, mark and cut a patch 2 ½ -inches wider and longer than the inside measurements of the prepared hole.
7. Center the patch material over the prepared hole. Pin the patch material in position.

8. Make a ½ -inch foldunder on each edge of the patch material and baste the patch to the prepared area. Basting will be performed using the procedures in the BASTING AND TEMPORARY TACKING paragraph detailed above.
9. Remove the pushpins securing the item to the repair table and secure the patch by stitching according to the details in the stitching specifics outlined in Tables 1 and 2.
10. Make the first row of stitching completely around the edges of the patch. Turn the item right-side-out (or vice versa) and make a second row of stitching around the edges of the prepared hole. Stitching will be performed in accordance with the STITCHING AND RESTITCHING paragraph detailed above.
11. If applicable, restencil informational data according to procedures in WP 0014 00.

NOTE

If the outside of a seam is damaged, cut away the seam in the damaged area and patch as a basic patch.

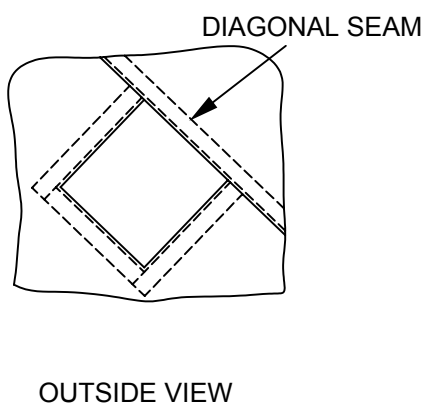
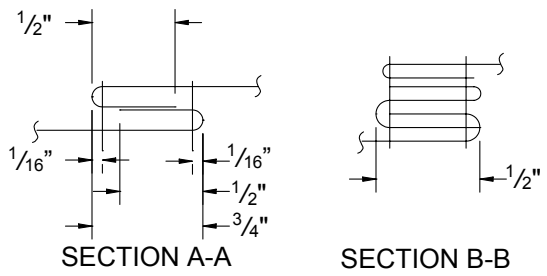
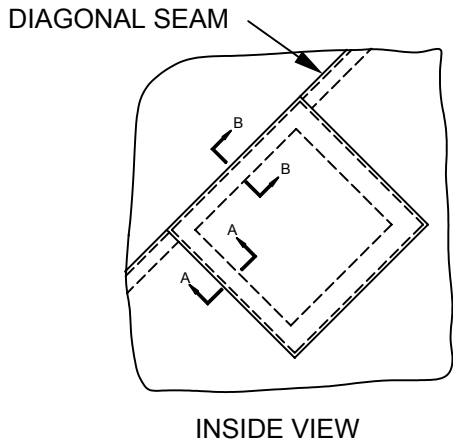

(A) RECTANGULAR PATCH INCLUDING A DIAGONAL SEAM

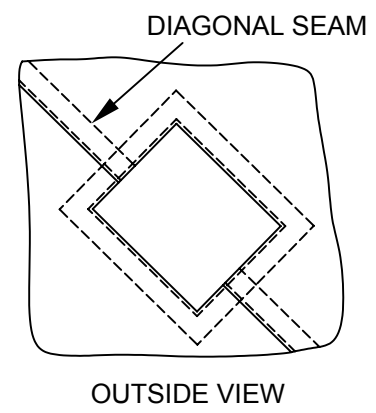
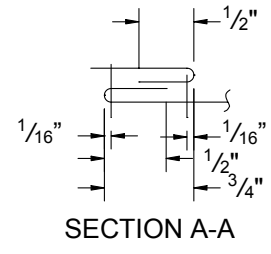
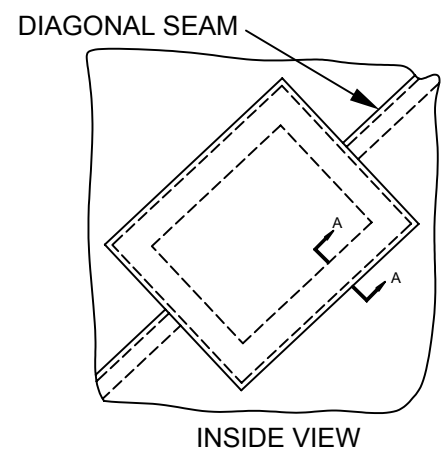

(B) RECTANGULAR PATCH CROSSING A DIAGONAL SEAM

END OF WORK PACKAGE

ANCILLARY EQUIPMENT FOR PERSONNEL PARACHUTE SYSTEM

SEARING AND WAXING

INITIAL SETUP:

Tools

Pot, Melting, Electric (WP 0034 00, Table 2, Item 10)
Knife, Hot, Metal (WP 0034 00, Table 2, Item 7)

Personnel Required

92R(10) Parachute Rigger

Materials/Parts

Beeswax, Technical (WP 0052 00, Table 1, Item 1)
Wax, Paraffin, Type I, Technical (WP 0052 00, Table 1, Item 52)

Equipment Condition

Unpacked

CAUTION

Cotton tape, webbing, or cord will not be seared. These products burn rather than melt. Serious damage will result.

NOTE

Fabric materials such as cord, tape, and webbing, that are cut for use in the maintenance of ancillary equipment will normally be heat-seared or dipped in melted wax mixture, as applicable, to prevent the material from fraying or unraveling. However, in some instances, the preparation of the material may not be necessary and will be specified accordingly.

SEARING

The cut ends of nylon tape, webbing and cord lengths may be prepared by heat-searing, which is performed by pressing the raw end of the material against a hot metal surface (knife) until the nylon has melted sufficiently. Avoid forming a sharp edge or lumped effect on the melted end.

WAXING

The fraying or unraveling of cotton or nylon tape, webbing, and cord length ends may be prevented by dipping ½ inch of the raw end of the material into a thoroughly melted mixture of half beeswax and half paraffin in an electric melting pot. The wax temperature should be substantial enough to ensure the wax completely penetrates the material, rather than just coating the exterior fabric.

END OF WORK PACKAGE

ANCILLARY EQUIPMENT FOR PERSONNEL PARACHUTE SYSTEM

MARKING AND RESTENCILING

INITIAL SETUP:

Tools

N/A

Personnel Required

92R(10) Parachute Rigger

Materials/Parts

Brush, Stenciling (WP 0052 00, Table 1, Item 3)
Ink, Marking (WP 0052 00, Table 1, Item 21)
Marker, Felt Tip, Black (WP 0052 00, Table 1, Item 25)
Pen, Ball Point (WP 0052 00, Table 1, Item 26)
Stencil Board, Oiled (WP 0052 00, Table 1, Item 29)

Equipment Condition

Laid out on packing table or other suitable area.

NOTE

Stenciling should be used whenever possible. A ballpoint pen or felt tip marker should be used only where stenciling is not possible, or when stenciling devices are not available. Any type ballpoint pen using black or blue ink may be used for marking on labels only.

Original stenciled data or marking that becomes faded, illegible, obliterated, or removed as a result of performing a repair procedure, will be remarked with a ballpoint pen, felt tip marker, or restenciled. All marking or restenciling will be done on, or as near as possible to, the original location and should conform to the original lettering type and size.

MARKING

Using marking devices, such as a ballpoint pen or felt tip marker, mark on, or as near as possible to, the original location and conform to the original lettering type and size.

RESTENCILING

Proceed as follows:

1. Cut oiled stencil board to match the original lettering type and size of data to be restenciled.
2. Place cut stencil board over, or as near as possible to, the original marking to be restenciled.
3. Place an additional sheet of stencil board beneath the area to be restenciled to prevent the marking ink from penetrating to other areas.
4. Hold the stencil board in place and, using the stenciling brush filled with parachute marking ink, restencil the original marking.

REMARKING AND RESTENCILING

Remark/restencil the original stenciled data/markings that become faded, illegible, obliterated, or that have been removed as a result of performing a repair procedure. Ensure all marking/restenciling is on, or as near as possible to, the original location, and conforms to the original lettering type and size.

RE-STENCILING AND RE-PAINTING

Painted markings on airdrop equipment that are chipped or worn will be repainted with the same color enamel paint. Metal and wood items may be repainted as required.

END OF WORK PACKAGE

UNIT MAINTENANCE

ANCILLARY EQUIPMENT FOR PERSONNEL PARACHUTE SYSTEM

SNAP FASTENER AND GROMMETS
REPAIR, REPLACE

INITIAL SETUP:

Tools

Diagonal Pliers (WP 0034 00, Table 2, Item 4)
 Double Bow Cutter (WP 0034 00, Table 2, Item 5)
 Lead Pig (WP 0034 00, Table 2, Item 8)
 Press, Hand Operated (WP 0034 00, Table 2, Item 11)
 Punch and Die for O-Grommets (WP 0034 00, Table 2, Item 12)
 Rawhide Mallet (WP 0034 00, Table 2, Item 13)
 Single Bow Cutter (WP 0034 00, Table 2, Item 21)

Personnel Required

92R(10) Parachute Rigger

Materials/Parts

Specified in paragraph applicable to the item being repaired.

Equipment Condition

Unpacked. Canopy with defects recorded.
 Clean.

Replacing Snap Fastener Assemblies. A snap fastener assembly is a four piece metal fitting used to secure flaps and tabs on parachute packs and harnesses. Two of the metal parts, the socket and clinch plate, or the button (cap) and socket, are installed on opposite sides of a flap or tab. The remaining two metal parts, the stud and the washer or stud and post, as applicable, are installed in a corresponding position on the main panel or body. The flap or tab is closed by snapping the mating parts together. The two types of snap fastener assemblies used on airdrop equipment are the pull-the-dot, and the durable as shown below. Repair or replace a defective snap fastener assembly using the following procedures, as appropriate:

REPAIR

- Repairs to Felt Lining. If felt lining is not damaged, darn or stitch as specified through lining. If felt lining is damaged, plug the felt material as described in the repair procedure for the applicable end item.
- The only repair that may be performed on a snap fastener assembly is reseating of the fastener which will be accomplished using the applicable procedures and tools prescribed in paragraph (2) below.

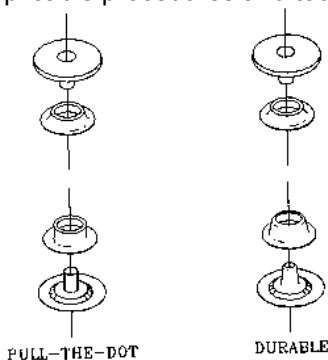

REPLACE

Replacement. A snap fastener assembly which is defective or cannot be reseated will be replaced with a serviceable item from stock. However, if only one part of a fastener is defective, such as the socket or stud, just that particular portion of the fastener assembly will necessitate replacement. Remove and replace a damaged snap fastener as follows:

1. Original snap fastener removal.
 - a. Cut the crimped edge of the applicable snap fastener assembly apart at three or four points with diagonal nippers.
 - b. Using a suitable type tool, pry back the fastener-crimped edges and remove the applicable defective fastener parts.
2. Repair and preparation of the original snap fastener area.
 - a. If the fabric area around the original snap fastener has been damaged, repair the area by darning, and the stitching specifics prescribed WP 0012 00. However, if darning does not provide and adequate repair, construct a suitable sized reinforcement to the inside of the damaged area using patching procedures and the stitching specifics described in WP 0012 00.
 - b. After repair of the fabric in the original snap fastener area has been completed, further preparation of the repaired area may be required according to the following criteria:
 - (1) When the replacement action involves a socket and clinch plate of a lift-the-dot snap fastener assembly, cut an appropriate sized hole in the repaired material to accommodate the size of the replacement fastener clinch plate and socket. Cutting the material will be accomplished using a rawhide mallet or other non-steel impact device, lead cutter block, and a lift-the-dot fastener cutter.
 - (2) Normally, the replacement of a lift-the-dot fastener assembly stud and washer, a pull-the-dot snap fastener assembly, or a durable snap fastener assembly does not require cutting of a fabric area prior to component installation. However, if a situation occurs which necessitates fabric cutting to accommodate any of the cited assemblies, the cutting process will be accomplished using a mallet and a lead cutter block as described in step (i), above and an appropriate sized double or single bow cutter.
 - c. Snap fastener installation
 - (1) General. Installation of a snap fastener may be performed by three different methods. The most common method is the hand-held method that requires the use of a leather mallet or other no-steel impact device, a holder to hold the appropriate sized chuck, and an anvil which is used to contain a compatible sized die. A second method of installing a snap fastener assembly is by use of the hand-operated press, the chuck or die are individually secured in position by a threaded screw that is tightened by using a suitable sized key (Allen-type hexagon wrench) or a flat-tip (common head) screwdriver, as applicable. The third method of snap fastener installation is by use of the foot-operated press which, except for the means of operation, functions similar to the hand-operated press.
 - (2) Installing a durable or pull-the-dot snap fastener assembly by the hand-held method.

- (3) Select the appropriate size die and chuck required for installing the fastener cap and socket or stud and post, as applicable.
- (4) Place the selected chuck in the open end of the holder and secure the chuck in place using the locking screw located on one side of the holder. Further place the appropriate die into the anvil.

NOTE

In most instances a chuck will be installed in the hand held holder and a die will be placed in the anvil. However, there may be some occasions that require the location of the chuck and die to be reversed. This situation may also apply to the hand or foot-operated press.

- (5) Fit the socket or stud, as applicable, on the chuck lower end. Place the cap or post, as applicable, on the die with the barrel facing up.
- (6) Position the material over the barrel of the cap or post, as applicable. Insure that the fastener socket or stud, as applicable, will be located on the proper side of the material for subsequent fastener engagement.
- (7) Place the socket or stud, as applicable, on the barrel of the cap or post, as applicable. With an applied strike from a mallet, clinch the two snap fastener components to the material.
- (8) Remove the clinched snap fastener components from the chuck and die set and check the seating of the joined components. If the applicable components are not properly seated, repeated the procedure in step (2) and (7) above.
- (9) Check the engagement of the installed snap fastener components with the opposite mating components with the opposite mating components to insure the open and closed snapping process is accomplished without hindrance. If the snap engaging process cannot be accomplished without difficulty, replace the opposite mating snap fastener components using the procedures in steps (2) through (7) above.

NOTE

A durable snap fastener assembly will open and close from any direction. A pull-the-dot snap fastener assembly will open and close from only one direction. A pull-the-dot snap fastener assembly will open and close from only one direction.

- (10)As required, remove the chuck and die from the applicable snap fastener tools by reversing the procedures in step (5) above.
- d. Hand or foot operated press method. Installation of durable or pull-the-dot snap fastener assemblies by hand or foot operated press can be accomplished by using the procedures in paragraph 1 above, except the chuck and die will be secured within the applicable press assembly using the available locking screws.
 - e. Installing the lift-the-dot snap fastener assembly.

- (1) Hand held method.

- (a) Using the specifics in table 2-4, ascertain the size chuck and die required the fastener socket and clinch plate or stud and washer. As applicable.
- (b) Place the selected chuck in the open end of the holder and secure the chuck in place using the locking screw located on one side of the holder. Further, place the appropriate die into the anvil.
- (c) Fit the socket (with prongs facing down) or stud (with barrel facing down) on the lower end of the chuck. Place the clinch plate or washer, as applicable on the die.
- (d) Position the material over the clinch plate or washer, as applicable.
- (e) Align the socket prongs with the pre-cut holes in the material or the barrel of the stud at the center of the material-covered washer, as applicable. With an applied strike from a mallet, clinch the two snap fastener components to the material.
- (f) Remove the clinched snap fastener components from the chuck and die set and check the seating of the joined components. If the applicable components are not properly seated, repeat the procedure in e above.
- (g) Check the engagement of the installed snap fastener components to insure the open and closed snapping process cannot be accomplished without difficulty, replace the opposite mating snap fastener components using the procedures in steps a through f, above.

NOTE

A lift-the-dot snap fastener assembly will open and close from only one direction.

- (2) Hand or foot operated press methods. Installation of a lift-the-dot snap fastener assembly by hand or foot operated press may be accomplished using the procedures in paragraph above, except the chuck and die will be secured within the applicable locking screws.

Replacement of Grommets. A grommet is a two piece metal eyelet used to reinforce and protect textile material at a point where a hole has been made to permit the threading of a line, chord, webbing or the insertion of a retainer device. The three types of grommets used on air-drop equipment are the flat, plain, and spur, each of which is installed with an applicable type washer. Repair or replace a defective grommet using the following procedures, as appropriate.

1. Repair. Remove burrs, rough spots, rust, or corrosion from an installed grommet by filing with a metal file or by buffing with a crocus cloth.
2. Reseat a loose grommet by using the applicable procedures described under grommet replacement.
3. Replacement. A grommet which is damaged or cannot be reseated will be replaced with a serviceable grommet and washer of the same size and type from stock and the following procedures, as applicable:

-
- a. Original grommet removal. Using a suitable type tool, lift the edge of the original washer at one point.
 - b. Grip the lifted washer edge with diagonal nippers and roll the washer edge back to lift the washer from the original grommet. Remove the original grommet from the material.
 - c. If the fabric area around the original grommet has been damaged, repair the area by darning, using the procedures in WP 0012 00. However, if darning does not provide an adequate repair, construct a suitable sized reinforcement of the same type material as that used in the original grommet location. Secure the reinforcement to the inside of the damaged area using the patching procedures in WP 0012 00.
 - d. Using a single or double bow cutter that is compatible with the size of the replacement grommet, a lead cutter block, and a rawhide mallet or other non-steel impact device, cut a hole in the repaired fabric area to accommodate the barrel of the replacement grommet. Insure the hole is cut with a slightly smaller diameter than the diameter of the barrel of the replacement grommet.
 - e. Install a plain or spur grommet by the hand-held method which requires the use of a suitable sized punch and die, and a rawhide mallet or other non-steel impact device. A flat grommet should also be installed using the hand-held method, but may be installed using a hand- or foot-operated press and a suitable size chuck and die.

CAUTION

Tools used to install a grommet will be compatible with the size and type of grommet.

- f. Insert the barrel of the replacement grommet through the accommodating hole in the material and insure the grommet flange is located on the same side of the material as the original grommet.
- g. Position the grommet on a suitable sized die with the barrel facing up and place the applicable washer over the grommet barrel.

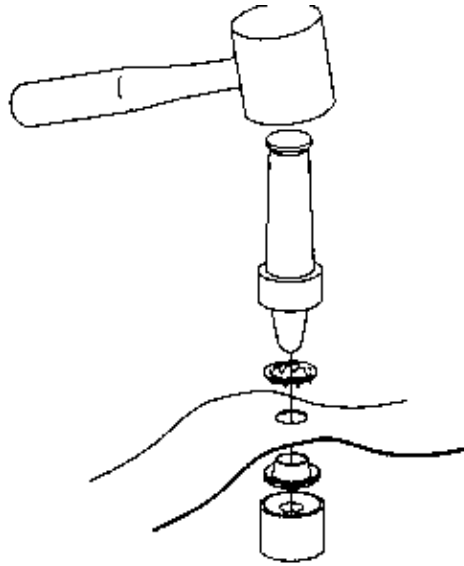
**NOTE**

When installing a flat grommet by the hand-held method, insure the grommet barrel and washer are aligned to preclude off-center setting of the grommet.

- h. Using a suitable sized punch and a rawhide mallet or other non-steel impact device, spread the grommet barrel by hammering as shown until the barrel collar is rolled down smooth on the washer. If the grommet barrel splits during the hammering process, remove and replace the installed grommet with a serviceable item from stock, subsequently repeating the procedures in f and g above.
- i. Check the seating of the grommet and if the grommet can be turned by hand, repeat the procedure in 3 above until the grommet is firmly seated.
- j. To install a flat grommet by hand-operated press install a suitable sized chuck and die on a hand- or foot-operated press. Secure the chuck and die in place using the available locking screws and a suitable sized key (Allen type hexagon wrench).
- k. Insert the barrel of the replacement grommet through the accommodating hole in the material as shown. Insure the flange of the replacement grommet is on the same side of the material as the original grommet.
- l. Position the grommet on the installed die with the barrel facing up and place the replacement washer over the grommet barrel.
- m. Depress the press handle or foot pedal and spread the grommet barrel until the collar of the barrel is rolled down smoothly on the washer.

- n. Check the grommet for a firm seating. If the grommet can be turned by hand, repeat the procedure in m above until a firm seating of the grommet is achieved.

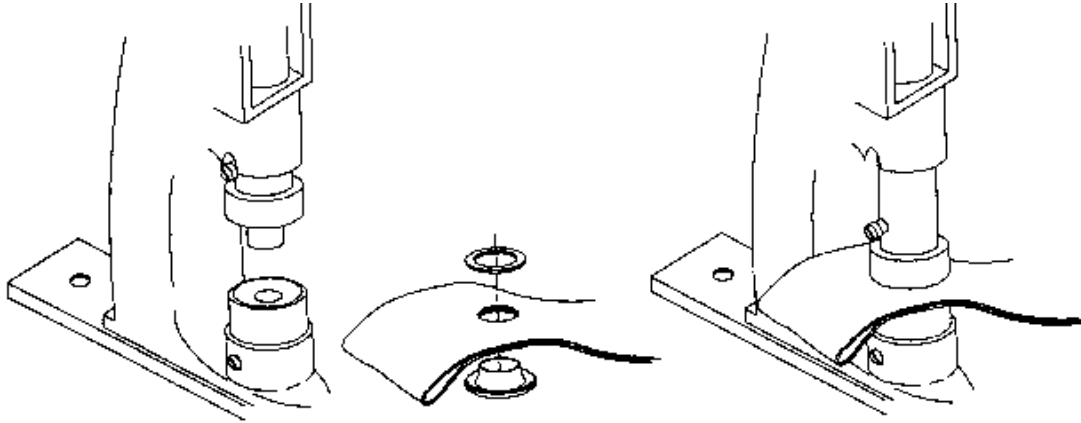

END OF WORK PACKAGE

ANCILLARY EQUIPMENT FOR PERSONNEL PARACHUTE SYSTEM

**5 FT EXTENSION STATIC LINE, STANDARD
INSPECT, REPLACE, REPAIR, INSTALL**

INITIAL SETUP:

Tools

Knife (WP 0034 00, Table 2, Item 6)
Shears (WP 0034 00, Table 2, Item 20)

Personnel Required

92R(10) Parachute Rigger

Materials/Parts

Cord, Nylon, OD nylon core Type II (WP 0052 00, Table 1, Item 13)
Cord, Nylon, OD nylon core Type III (WP 0052 00, Table 1, Item 12)
Tape, Masking, 2-inch (WP 0052 00, Table 1, Item 79)
Thread, Nylon, Size 6 (WP 0052 00, Table 1, Item 49)
Wire, Steel (WP 0052 00, Table 1, Item 77)

Equipment Condition

Static line extension removed from static line.
Position on worktable in extended position.
Extension must be clean and dry.

INSPECT

Perform a before and after repair technical/rigger type inspection of the 5-foot standard static line extension as outlined in WP 0008 00.

REPLACE

Remove the 5-foot long standard static line extension (1) from the 15-foot standard static line (2). Replace damaged safety pin (3) or lanyard (4) as described in the repair procedures. If the extension is unserviceable because of frays, cuts, worn areas or other defects in the fabric, replace the extension with a serviceable item from stock.

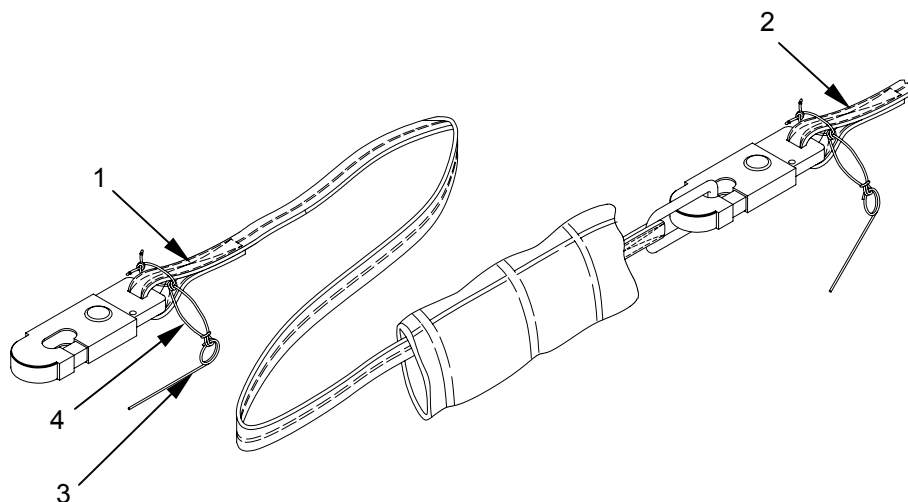

REPAIR

Repair the standard static line extension safety pin and lanyard as follows:

1. Cut a 5 inch length of steel wire and construct a new safety pin (**3**) as shown in WP 0053 00.
2. To prepare a new lanyard cut a 20-inch length of Type II or Type III nylon cord. Remove the core threads, tie an overhand knot at each end (**1**), and sear both ends (**2**) as described in WP 0013 00. Secure cord to safety pin (**3**) and static line snap hook (**4**) as shown.

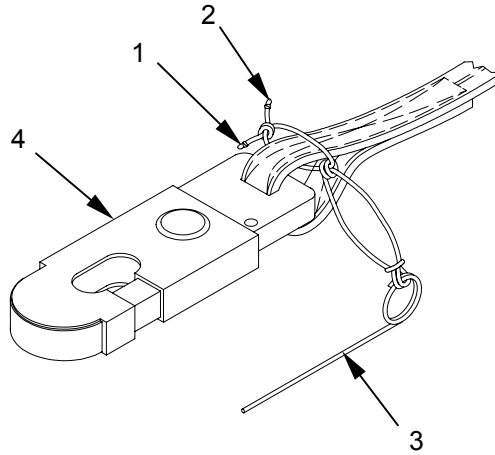

INSTALL

Install the standard 5-foot extension onto the static line by attaching the ring (1) of the extension to the snap hook (2) of the standard 15-foot static line. Install and bend safety pin (3). Slide the permanently attached cover (4) on the extension over the snap hook of the standard 15-foot static line (5) and tie and tape in place using 2-inch wide masking tape.

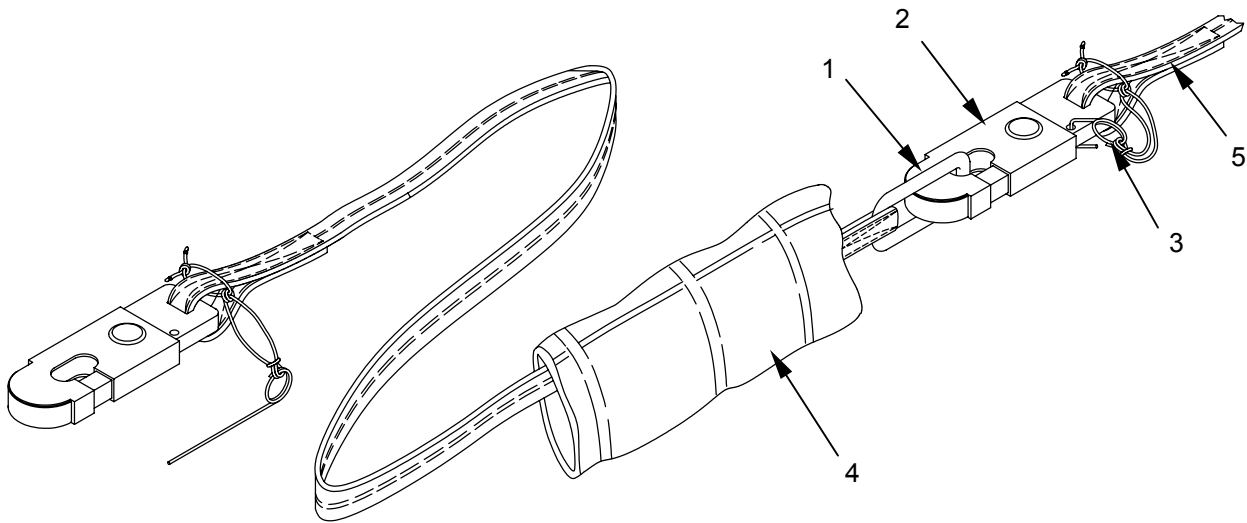

END OF WORK PACKAGE

ANCILLARY EQUIPMENT FOR PERSONNEL PARACHUTE SYSTEM

ACCESSORY SET, SCUBA
INSPECT, SERVICE, REPLACE, INSTALL

INITIAL SETUP:

Tools

Knife (WP 0034 00, Table 2, Item 6)
Screwdriver, Flat tip (WP 0034 00, Table 2,
Item 14)
Shears (WP 0034 00, Table 2, Item 20)

Personnel Required

92R(10) Parachute Rigger

Materials/Parts

Cord, Nylon, OD nylon core Type III (WP 0052
00, Table 1, Item 13)
Tape, Pressure Sensitive, 2-inch (WP 0052 00,
Table 1, Item 40)
Thread, Nylon, Size 3 (WP 0052 00, Table 1,
Item 47)
Thread, Nylon, Size E (WP 0052 00, Table 1,
Item 50)
Thread, Nylon, Size 6 (WP 0052 00, Table 1,
Item 49)

Equipment Condition

SCUBA Accessory Set equipment components
removed from other parachute equipment.
Components must be clean, dry and separated.

INSPECT

Perform a before and after repair technical/rigger type inspection of the scuba accessory set as outlined in WP 0008 00.

SERVICE

Wrap the center portion of the shield, if serviceable, prior to each use with 2-inch waterproof adhesive tape.

REPLACE

Replace damaged support straps (1), Backstrap Harness (2), or Waistband Extension Strap (3) with new items manufactured as described in WP 0053 00, or repair items by restitching where required. Replace a damaged shield (4) with a serviceable item from stock.

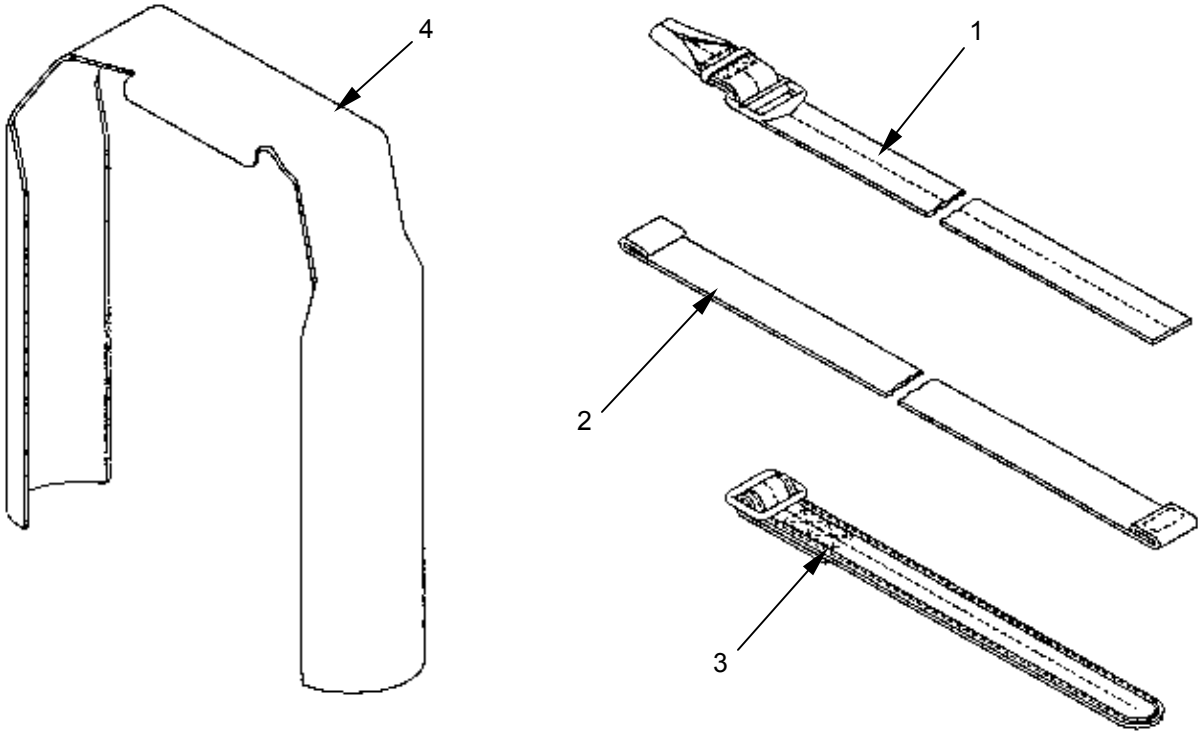

INSTALL

To install the shield (1) over the airtanks (2), loosen the two retaining screws (3) between the airtanks. Insert the ends of the shield between the outside of the airtanks and the metal straps (4). Push shield down over regulator valves (5), and tighten retainer screws (3).

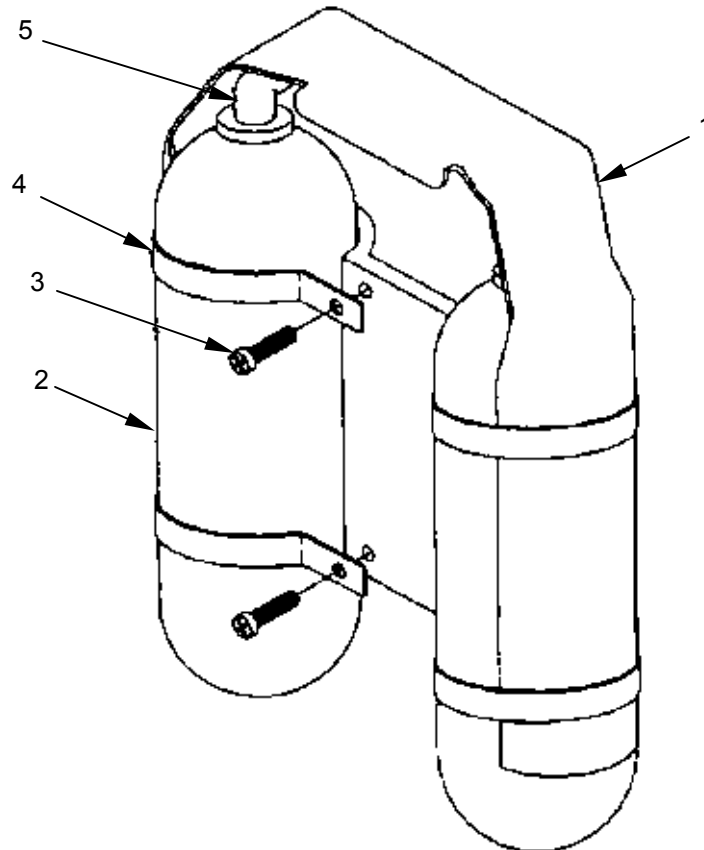
**END OF WORK PACKAGE**

ANCILLARY EQUIPMENT FOR PERSONNEL PARACHUTE SYSTEM

**LINE, LOWERING, 15-FOOT
INSPECT, REPAIR, REPLACE**

INITIAL SETUP:

Tools

Knife (WP 0034 00, Table 2, Item 6)
Shears (WP 0034 00, Table 2, Item 20)
Sewing Machine, HD (WP 0034 00, Table 2, Item 16)
Sewing Machine, LD (WP 0034 00, Table 2, Item 17)
Sewing Machine, Zig Zag (WP 0034 00, Table 2, Item 19)

Personnel Required

92R(10) Parachute Rigger

Equipment Condition

Lowering line and attaching webbing detached from other equipment and placed on worktable. Lowering line must be clean and dry.

Materials/Parts

Cord, Nylon, Type II (WP 0052 00, Table 1, Item 13)
Marker, Felt Tip (WP 0052 00, Table 1, Item 25)

Tape, Fastener hook (WP 0052 00, Table 1, Item 34)
Tape, Fastener Pile (WP 0052 00, Table 1, Item 36)
Tape, Nylon, Type III, 3/4-IN. (WP 0052 00, Table 1, Item 80)

Materials/Parts (Cont)

Tape, Fastener Pile (WP 0052 00, Table 1, Item 36)
Thread, Nylon, Size 3 (WP 0052 00, Table 1, Item 47)
Thread, Nylon, Size E (WP 0052 00, Table 1, Item 50)
Webbing, Tubular, Nylon, 1-IN., Yellow (WP 0052 00, Table 1, Item 81)

INSPECT

Perform a before and after repair technical/rigger type inspection of the lowering line as outlined in WP 0008 00.

REPAIR

CAUTION

Splicing of the lowering line and attaching web is not authorized. Serious equipment damage may occur due to failure of a spliced lowering line or attaching web.

NOTE

If replacing the hook and pile fastener on the running end of the lowering line, reverse the location of both the hook and pile to prevent wear and tear of the lowering line.

Repair a lowering line and attaching web by restitching as required using size E thread, 7 to 11 stitches per inch and a LD sewing machine.

Replace the hook and pile fastener on the lowering line pocket as follows:

1. Remove damaged piece of hook **(1)** and/or pile **(2)** fastener.
2. Cut a new 2-inch length of hook tape **(1)**, and a new 4-inch length of pile tape.
3. Place a mark, $\frac{3}{8}$ -inch, and $2\frac{3}{8}$ -inches from the retainer binding on the folded loop side of the 1-inch wide lowering line.
4. With hook side facing up, position the 2-inch hook tape between the $\frac{3}{8}$ and the $2\frac{3}{8}$ -inch markings, and stitch with a single box stitch, using size E thread, 7 to 11 stitches per inch and a LD sewing machine.
5. Place a mark 1-inch from the binding edge on the pile flap retainer at the folded loop end of the lowering line.
6. With pile side facing up, position edge of 4-inch pile tape on 1-inch marking with opposite end extending over binding edge. Stitch to pile flap retainer with a single box X stitch using size E thread, 7 to 11 stitches per inch and a LD sewing machine.

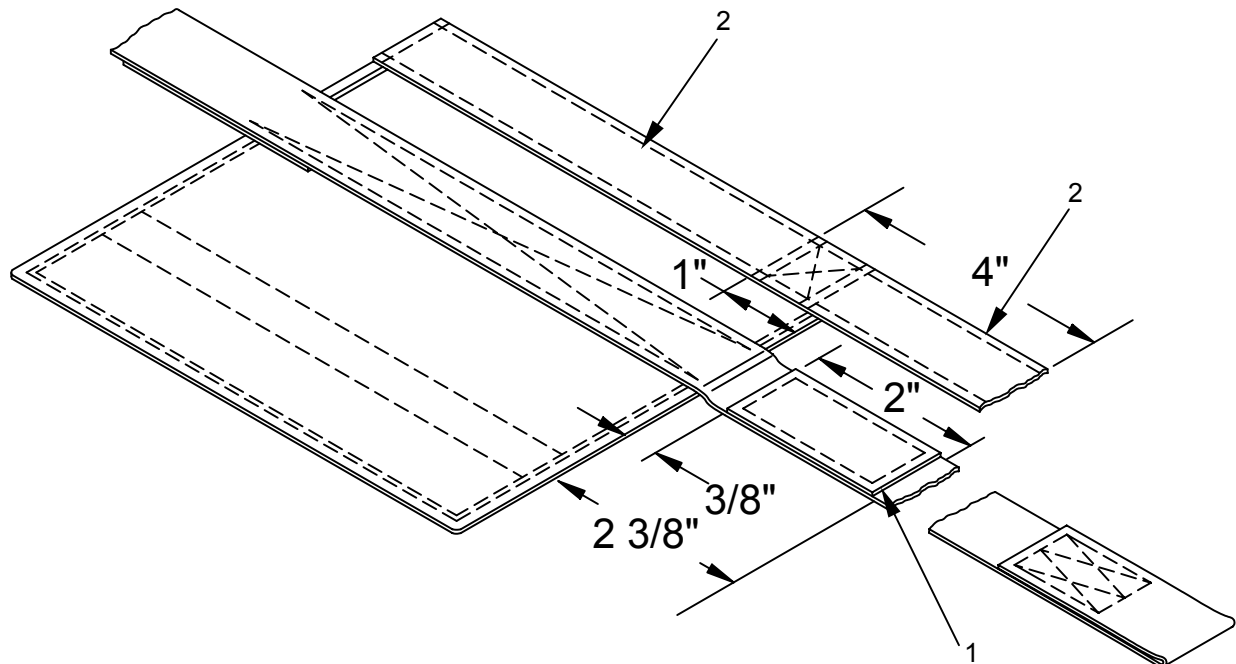

REPLACE

Replace the quick-ejector snap (1) by carefully cutting and removing stitching which secures the item to the lowering line (2). Place buffer (3) and lowering line (2) on serviceable quick-ejector snap (1) as in original and stitch with 3-inch, 3 point WW stitch using size 3 thread, 5 to 8 stitches per inch, and an HD sewing machine.

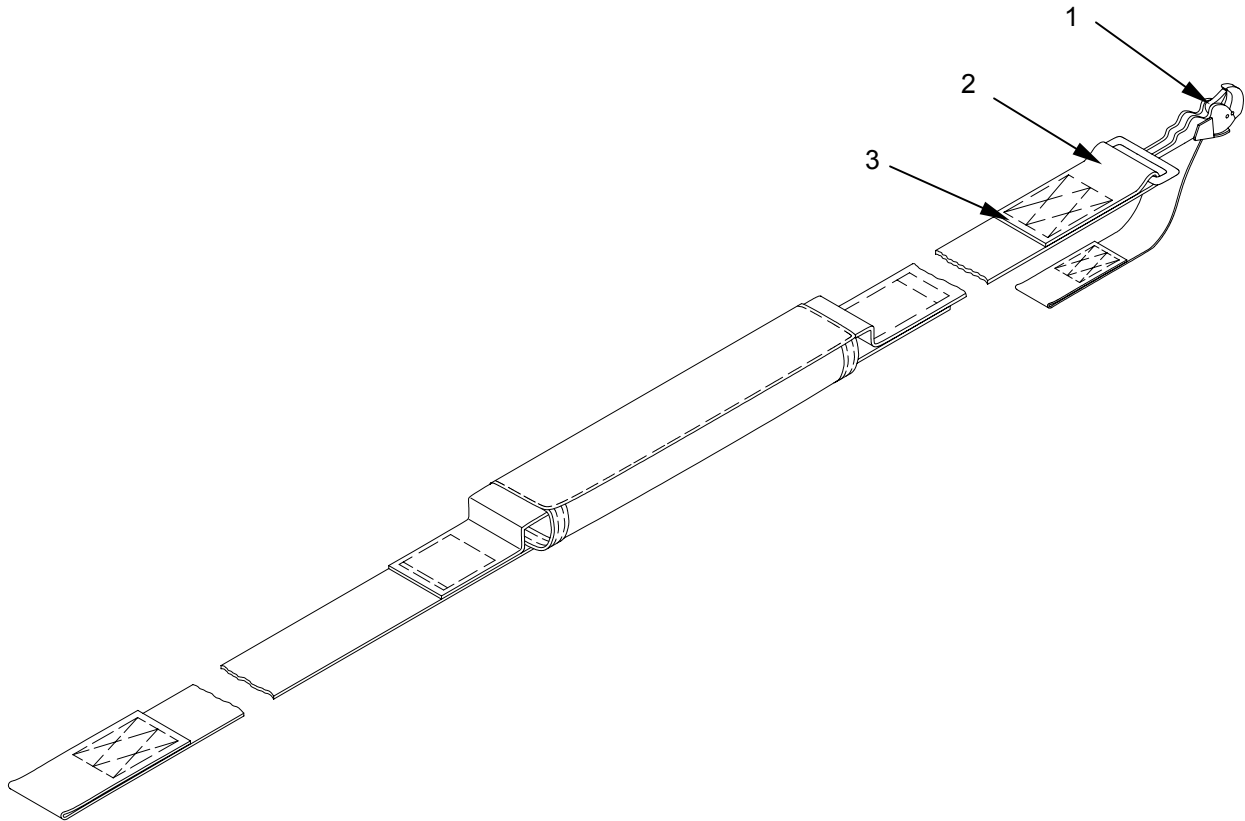

Replace the yellow pull to release lanyard (4) as follows:

1. Cut a 10 ½-inch length of yellow, 1-inch wide type I nylon webbing and sear both ends.
2. Cut a 5 ½-inch length of ¾-inch wide type III nylon tape.
3. Cut two 6 ¾-inch lengths type II nylon cord and sear both ends.
4. Fold the 5 ½-inch length of ¾-inch nylon tape in half.
5. Fold both lengths of the type II nylon cord in half and lay both lengths side by side on top of the ¾-inch nylon tape.

6. Ensure the folded edges of the type II nylon cord extend 5/8-inch over the folded edge of the 3/4-inch nylon tape.
7. With the nylon cord laid out side by side, stitch the cord to the tape using a zig zag sewing machine and size E nylon thread, 7 to 10 stitches per inch. The width of the zigzag will be 3/16-inch.

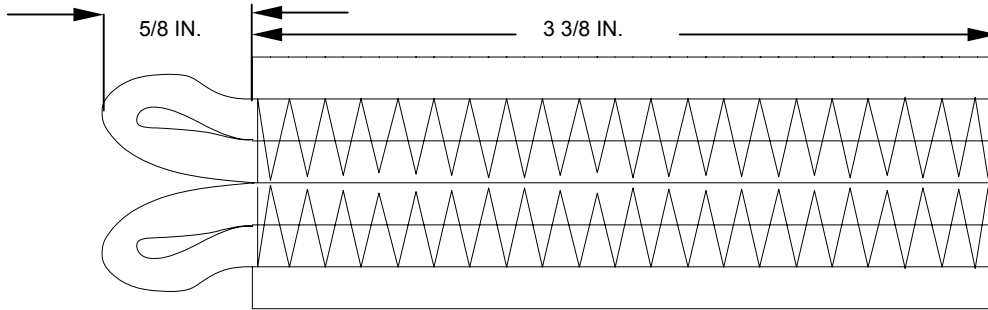

8. Retrieve the 10 1/2-inch length of yellow, 1-inch wide type I nylon webbing and place a mark 3/4-inch from one end and triple fold the webbing ensuring the final folded dimension measures 3/4-inch.
9. Stitch the folded edge with a single box X stitch formation 1/8-inch from each edge using size 3 thread, 5 to 8 stitches per inch and a MD sewing machine.
10. Insert the newly formed double loop sub-assembly into the opposite end of the 1-inch wide type I nylon webbing until 1/2-inch of the loop assembly is sticking out.
11. Stitch a 2-inch long single box X stitch formation 1/8-inch from the leading edge and maintain that 1/8-inch edge on the top and bottom of the webbing using size 3 thread, 5 to 8 stitches per inch and a HD sewing machine.

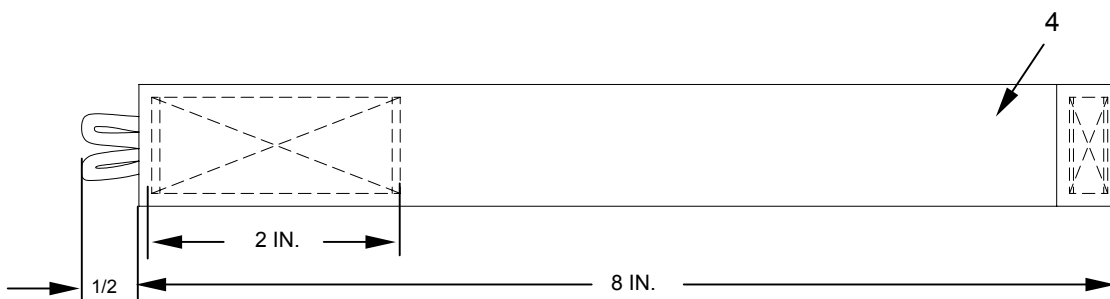

12. Place each cord loop over each of the lever arms of the ejector snap (1) and position to the center.
13. Hand tie cord loops in the location shown with two turns of waxed nylon thread, size 3. Secure with a surgeons knot-locking knot and cut ends of thread to within ½-inch.

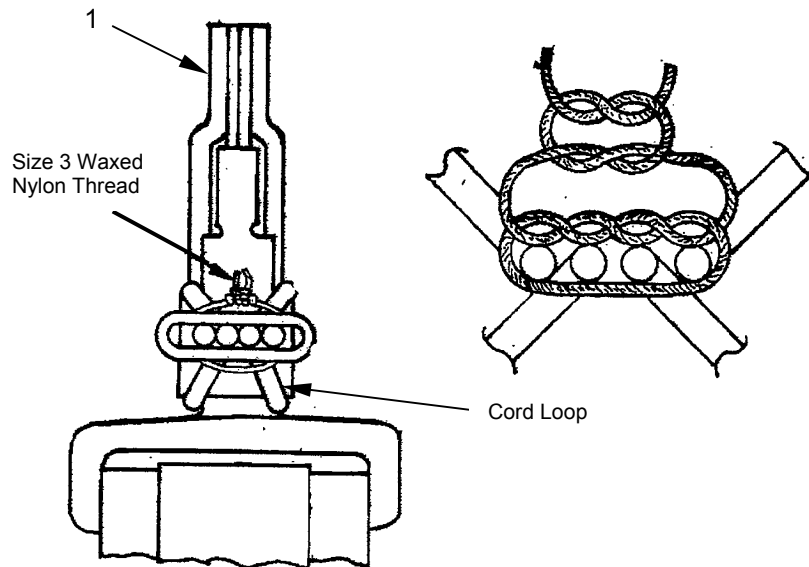

14. Replace any defective lowering line that cannot be repaired.

END OF WORK PACKAGE

ANCILLARY EQUIPMENT FOR PERSONNEL PARACHUTE SYSTEM

**JUMP PACK, DRAGON MISSILE
INSPECT, REPAIR, REPLACE**

INITIAL SETUP:

Tools

Knife (WP 0034 00, Table 2, Item 6)
Pot, Melting (WP 0034 00, Table 2, Item 10)
Shears (WP 0034 00, Table 2, Item 20)
Sewing Machine, HD (WP 0034 00, Table 2, Item 16)
Sewing Machine, Darning (WP 0034 00, Table 2, Item 15)
Sewing Machine, LD (WP 0034 00, Table 2, Item 17)

Personnel Required

92R(10) Parachute Rigger

Materials/Parts

Felt, 1/4-inch (WP 0052 00, Table 1, Item 17)
Marker, Felt Tip (WP 0052 00, Table 1, Item 25)
Tape, Fastener hook (WP 0052 00, Table 1, Item 33)
Tape, Fastener pile (WP 0052 00, Table 1, Item 37)
Thread, Nylon, Size 3 (WP 0052 00, Table 1, Item 47)
Thread, Nylon, Size E (WP 0052 00, Table 1, Item 50)
Wax, Paraffin, Type I Technical, 1 lb (WP 0052 00, Table 1, Item 52)
Beeswax, Technical, 1 Lb (WP 0052 00, Table 1, Item 1)
Webbing, Nylon, Type VIII (WP 0052 00, Table 1, Item 61)
Webbing, Nylon, Type X (WP 0052 00, Table 1, Item 62)
Webbing, Nylon, Type II (WP 0052 00, Table 1, Item 57)

Equipment Condition

The dragon missile jump pack should be clean and dry. Place the pack to be repaired on worktable.

INSPECT

Perform a before and after technical/rigger type inspection of the dragon missile jump pack as outlined in WP 0008 00.

REPAIR

The cotton or nylon duck fabric of the pack may be restitched, darned, patched and plugged.

Restitching. Restitch the pack fabric (1) directly over old stitching using size 3 thread, 5 to 8 stitches per inch, and an HD sewing machine. Lock stitching at least 1/2-inch.

Darning. Darn a hole or tear in the pack fabric that does not exceed 1-inch in length or diameter using size E thread and a darning machine. There is no limit to darns that may be applied, provided they do not

weaken or reduce the original strength of the fabric more than 10%. If damage is in the lined portion of the container body and only the cotton duck is damaged, darn through duck and felt. If felt is also damaged, remove damaged area before darning duck fabric. Then plug felt as in 3 below.

Patching. There is no limit to the number of times the container body may be patched. Patch a hole or tear that exceeds 1-inch in length or diameter following procedures in 1 or 2 below. Use nylon or cotton duck cloth according to original construction for patching outside, and 1/4-inch thick felt for plugging inside lining. Use a HD sewing machine, size 3 thread, and 5 to 8 stitches per inch.

1. To patch a lined portion of the pack (1) when the felt (2) is not damaged, cut nylon or cotton duck patch (3) 2-inches beyond circumference of damaged portion. Turn under edges of patch 1/2-inch and center patch over damaged area. Sew patch to container body with a double row of stitching (4) as shown.

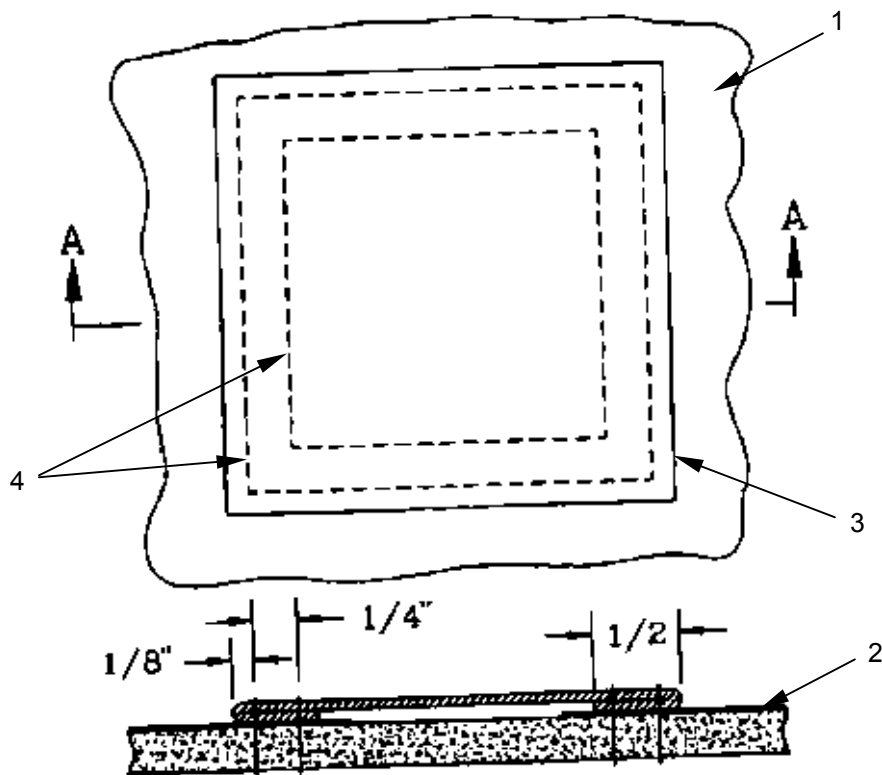

SECTION A-A

- To patch a lined portion of the pack (1) when the felt (2) is damaged, remove the damaged felt as described in 3 below. Cut a piece of felt (2) the same size as the piece removed, and position felt plug and cotton duck patch (3) (with edges turned under 1/2-inch) over damaged area. Sew a single box X stitch (4) formation as shown.

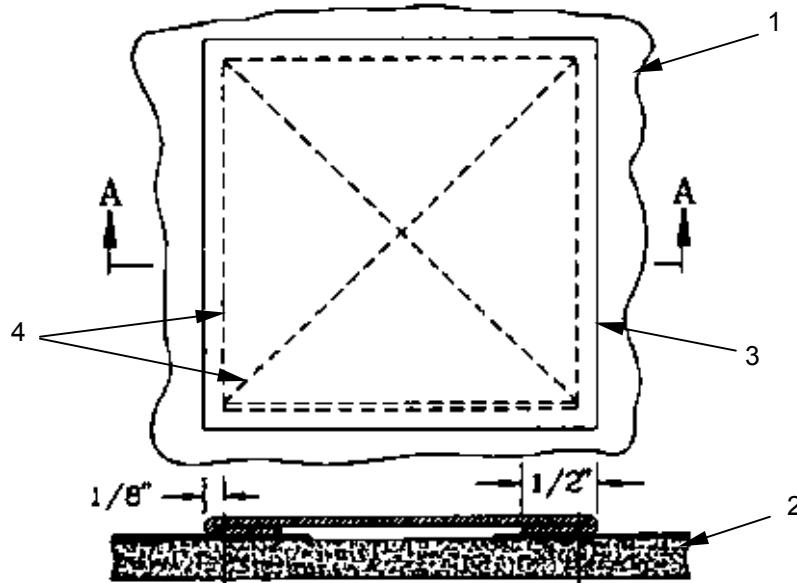

- To plug the main or end panels of felt (1) lining, mark a rectangle around the damaged area. Remove the damaged felt while being careful not to damage the cotton duck material (2). Cut a piece of felt (1) the size of the piece removed. Position felt plug into area cleared and sew as shown. Use size 3 thread, 5 to 8 stitches (3) per inch and a HD sewing machine.

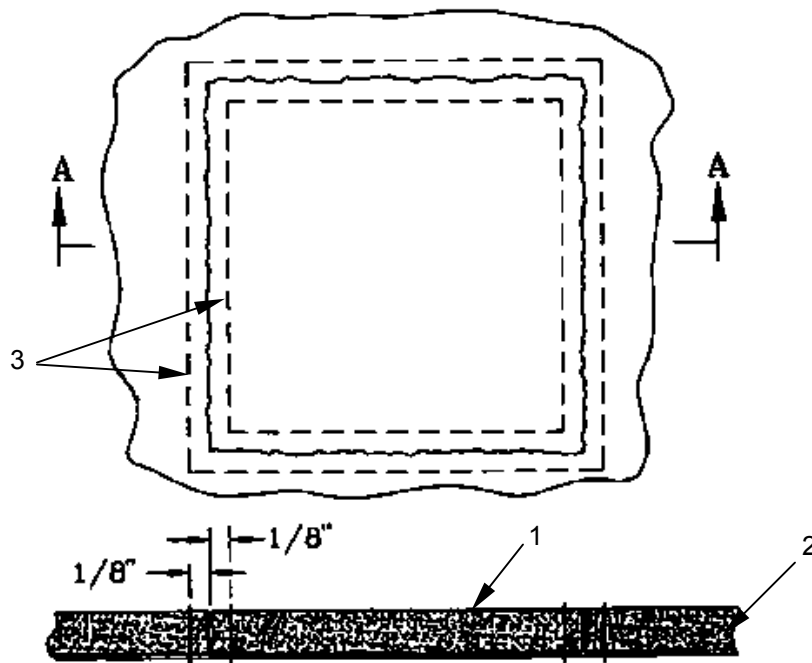

4. If damage is in an area that cannot be sewed by machine, tack felt plug (1) securely to cotton duck (2) as shown using doubled and waxed size 3 nylon thread. Secure thread ends with suitable knot.

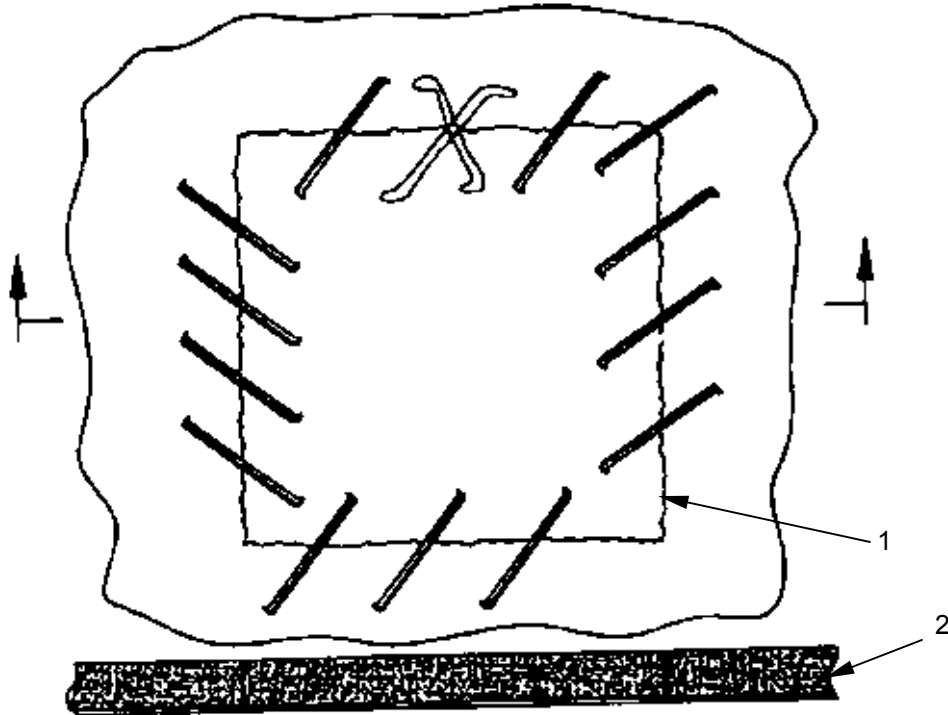

CAUTION

If webbing is inadvertently damaged when stitching is being removed, the webbing must be replaced in accordance with original construction.

Repair webbing items (1) by restitching. Use size 3 thread, 5 to 8 stitches per inch, and a HD sewing machine. Lock stitching at least $\frac{1}{2}$ -inch.

CAUTION

Splicing of the lowering line is not authorized. Serious equipment damage may occur due to failure of a spliced lowering line.

1. Repair lowering line (2) by restitching. Use size E thread, 7 to 11 stitches per inch, and a HD sewing machine. Lock stitching at least 1/2-inch.
2. Repair lowering line pocket (3) by restitching. Use size 3 thread, 5 to 8 stitches per inch, and a HD sewing machine. Lock stitching at least 1/2-inch.

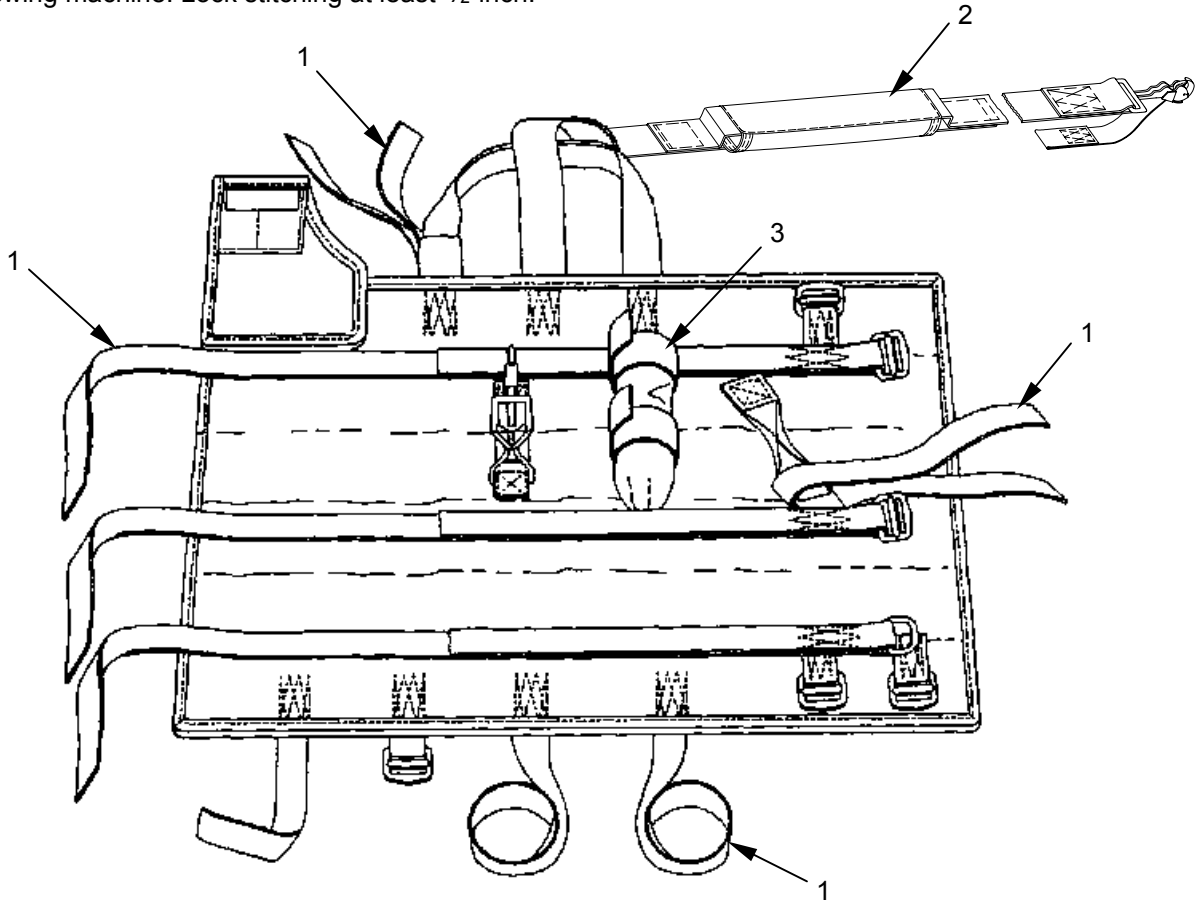

REPLACE

Replace webbing components in accordance with original construction as follows:

1. Carefully remove stitching that holds the item **(1)** to be replaced to the pack **(2)**. Remove damaged webbing and hardware **(3)** if applicable.
2. Cut new webbing material in appropriate length and type required, and install hardware if applicable. (Chapes, Side and rifle butt securing straps require Type VIII webbing; forward and aft cross straps require Type X, and the leg and upper tiedown require Type II webbing).

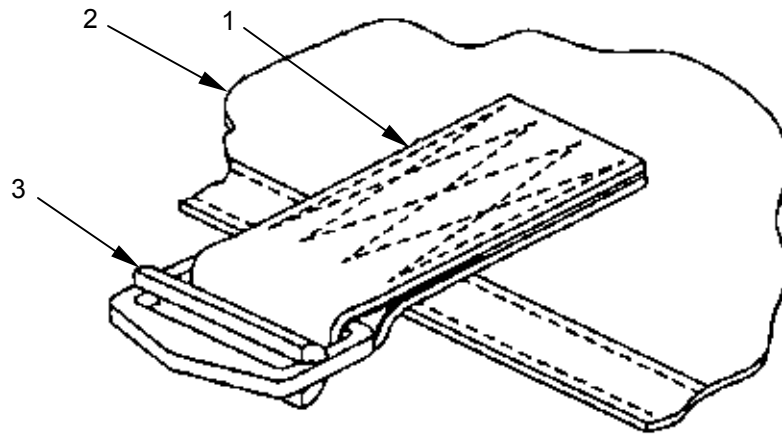
**CAUTION**

Splicing of the lowering line is not authorized. Serious equipment damage may occur due to failure of a spliced lowering line.

3. Turn under edges as in item removed. Place webbing on pack and sew using size 3 thread, 5 to 8 stitches per inch, and a HD sewing machine. Lock stitching at least $\frac{1}{2}$ -inch.
4. If it cannot be repaired by restitching, replace the lowering line entirely.
5. Replace a lowering line pocket, if it cannot be repaired by restitching. Fabricate new pocket as described in WP 0053 00, and sew to pack as shown using size 3 thread, 5 to 8, stitches per inch, and a HD sewing machine. Lock stitching at least $\frac{1}{2}$ -inch.

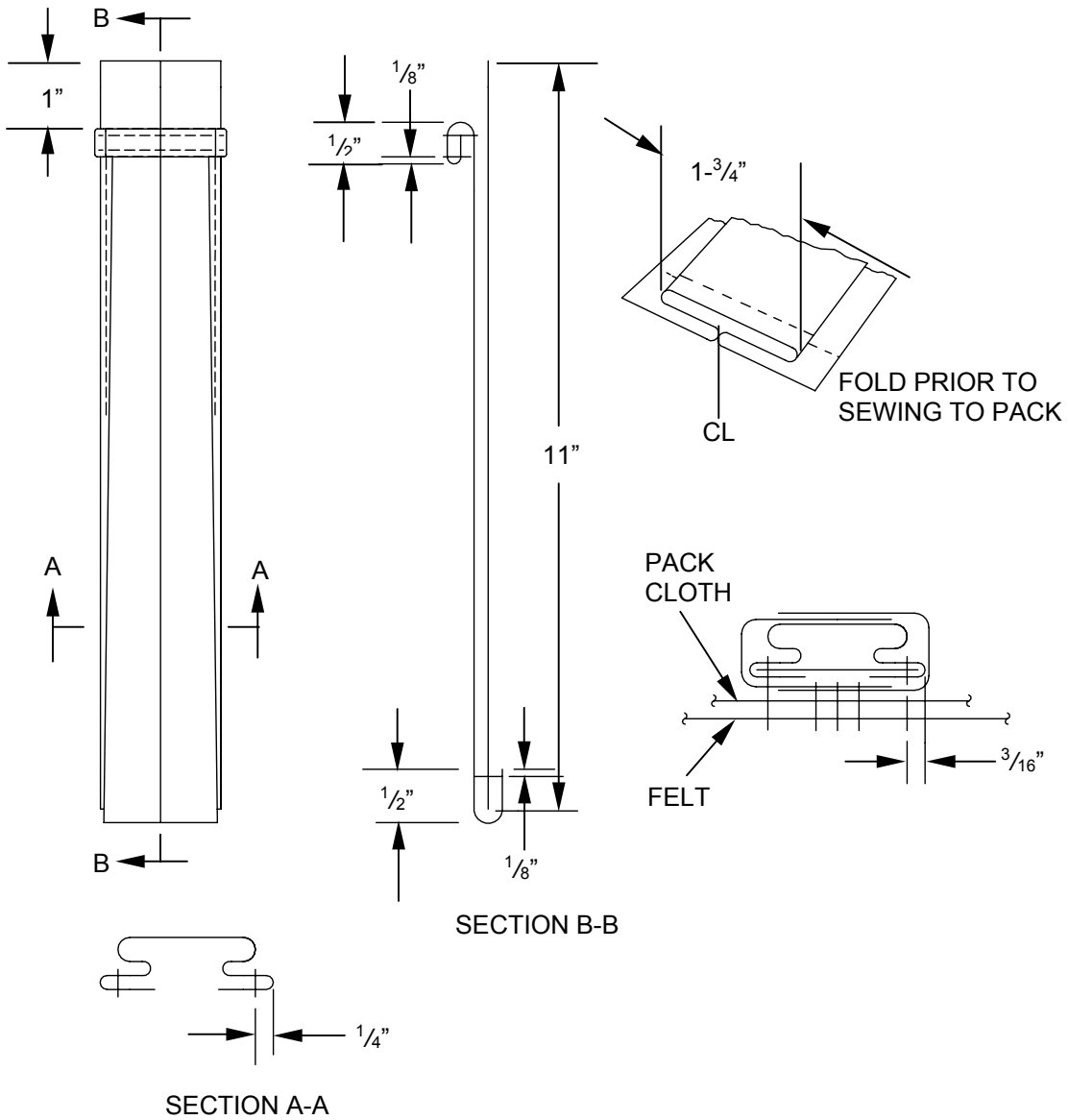

To replace the hook and pile fastener, proceed as follows:

NOTE

If replacing the hook and pile fastener on the running end of the lowering line, reverse the location of both the hook and pile to prevent wear and tear of the lowering line.

1. Remove damaged piece of hook or pile tape.
2. Cut a 2-inch length of hook tape.
3. Cut a 4-inch length of pile tape.
4. Place a mark $\frac{3}{8}$ -inch and $2\frac{3}{8}$ -inches from the retainer binding on the folded loop side of the 1-inch wide lowering line **(1)**.
5. With hook side facing up, position the 2-inch hook tape between the $\frac{3}{8}$ and $2\frac{3}{8}$ -inch markings. Stitch with a single box stitch using size E thread, 7 to 11 stitches per inch and an LD sewing machine.
6. Place a mark 1-inch from the binding edge on the pile flap retainer at the folded loop end of the lowering line **(1)**.
7. With the pile side facing up, position edge of 4-inch pile tape on 1-inch marking with opposite end extending over binding edge. Stitch with a single box stitch using size E thread, 7 to 11 stitches per inch and an LD sewing machine.

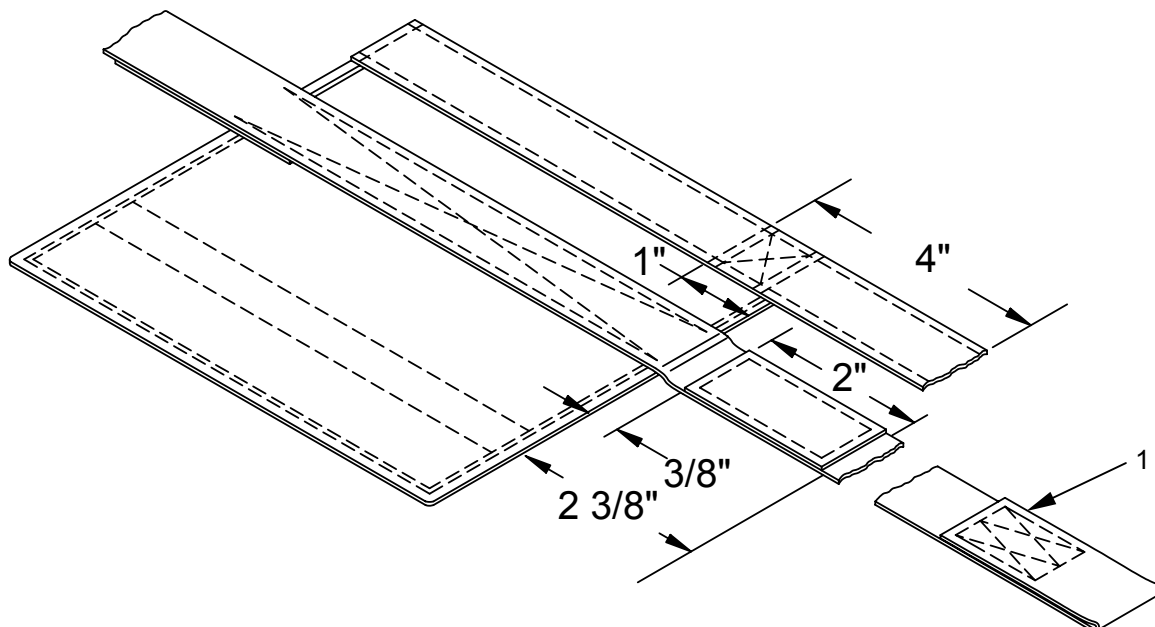

END OF WORK PACKAGE

UNIT MAINTENANCE

ANCILLARY EQUIPMENT FOR PERSONNEL PARACHUTE SYSTEM

HARNESS, SINGLE POINT RELEASE
INSPECT, REPAIR, REPLACE**INITIAL SETUP:****Tools**

Compressing tool (WP 0034 00, Table 2, Item 2)
 Cutter, Cable (WP 0034 00, Table 2, Item 3)
 Cutters, Diagonal Pliers (WP 0034 00, Table 2, Item 4)
 Knife (WP 0034 00, Table 2, Item 6)
 Pot, Melting (WP 0034 00, Table 2, Item 10)
 Sewing Machine, Darning (WP 0034 00, Table 2, Item 15)
 Sewing Machine, HD (WP 0034 00, Table 2, Item 16)
 Sewing Machine, MD (WP 0034 00, Table 2, Item 18)
 Sewing Machine, ZZ (WP 0034 00, Table 2, Item 19)
 Shears (WP 0034 00, Table 2, Item 20)

Personnel Required

92R(10) Parachute Rigger

Materials/Parts

Beeswax, Technical, 1-lb cake (WP 0052 00, Table 1, Item 1)
 Cord, Nylon, Red (WP 0052 00, Table 1, Item 11)
 Cord, Nylon, Type III (WP 0052 00, Table 1, Item 12)
 Grommet, Spur Type (WP 0052 00, Table 1, Item 20)
 Tape, Fastener Hook, 1 ½-inch wide (WP 0052 00, Table 1, Item 32)
 Tape Fastener, Pile 1 ½-inch wide (WP 0052 00, Table 1, Item 35)
 Thread, Nylon, Size 3 (WP 0052 00, Table 1, Item 47)
 Thread, Nylon, Size E (WP 0052 00, Table 1, Item 50)
 Thread, Nylon, Size FF (WP 0052 00, Table 1, Item 51)
 Wax, Paraffin, Type I, Technical, 1 lb cake (WP 0052 00, Table 1, Item 52)
 Webbing, Nylon (WP 0052 00, Table 1, Item 61)
 Webbing, Nylon, Type IV (WP 0052 00, Table 1, Item 60)
 Webbing, Tubular, Nylon (WP 0052 00, Table 1, Item 75)
 Wire, Steel (WP 0052 00, Table 1, Item 77)

Equipment Condition

The harness assembly should be clean and dry.
 Place assembly on worktable.

INSPECT

Perform a before and after technical/rigger type inspection of the harness single point release as outlined in WP 0008 00.

REPAIR

Repair harness webbing by restitching or darning. Splicing of webbing is restricted to the release handle lanyard (1) and straps not required to be adjusted through quick fit adapters (2) or side release buckles (3).

Restitching. Restitch the harness webbing directly over old stitching using size 3 thread, 5 to 8 stitches per inch, and a HD sewing machine. Lock stitching at least $\frac{1}{2}$ -inch.

Darning. Darn a tear in the harness webbing that does not exceed 1-inch in length or diameter using size E thread and a darning machine (DN or ZZ). There is no limit to darns that may be applied; provided they do not weaken or reduce the original strength of the webbing more than 10%.

Splicing. Cut a piece of $\frac{5}{8}$ -inch tubular or $1\frac{3}{4}$ -inch wide nylon webbing as appropriate, long enough to extend a minimum of 1-inch beyond each side of damaged area and sear ends as described in WP 0013 00. Center splicing material lengthwise over damaged area and stitch with a three point WW for the $\frac{5}{8}$ -inch tubular and 4 point WW pattern for the $1\frac{3}{4}$ -inch webbing the length of the splice.

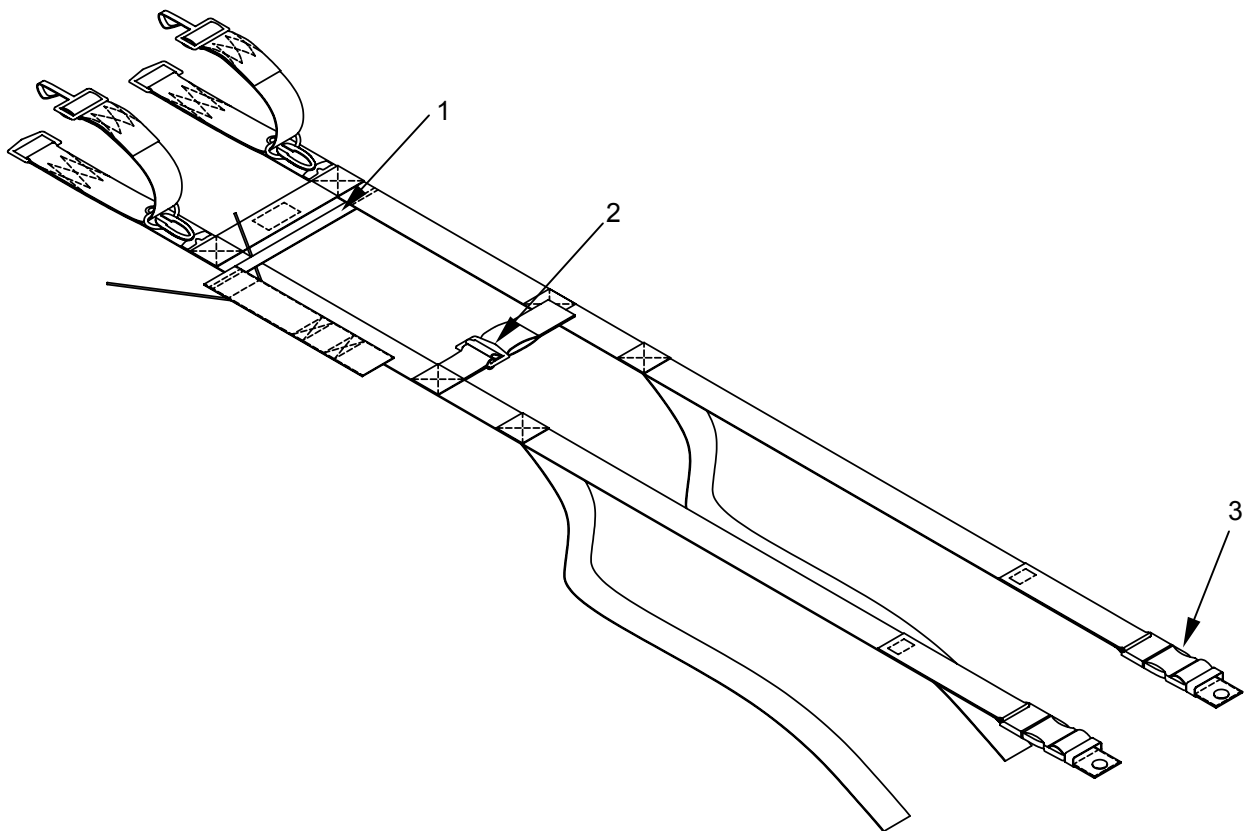

REPLACE

Replace a damaged cord loop "A", "B" or "C" as follows:

1. Replacement of cord loop "A" **(1)**.
 - a. Carefully cut and remove stitching **(2)** which secures the fixed web keeper **(3)** to the harness. Cut replacement Type VIII nylon web keeper **(3)** the length of the removed keeper **(3)** and sear ends.
 - b. Carefully cut and remove stitching **(4)** that secures the loop **(1)** to the harness in two places **(4)** and discard. Cut an 8 1/4-inch length of 5/8-inch width, natural color tubular nylon and sear ends.
 - c. Position tubular nylon loop **(1)** as in original location and stitch with double-throw zigzag or straight zigzag stitching, two places **(4)** forming loop. Use size E thread, 7 to 10 stitches per inch, and a ZZ sewing machine.
 - d. Position web keeper **(3)** 2 3/8-inches from outside edge of loop **(1)** as in original and stitch with double box X stitch pattern. Use size FF thread, 6 to 9 stitches per inch, and a MD sewing machine. The two plies of web keeper **(3)** shall be located on the loop side of the harness.

2. Replacement of cord loop "B" **(5)**.
 - a. Carefully cut and remove stitching **(6)** that secures the 1-inch wide fixed web keeper **(7)** to the harness. Cut replacement Type IV nylon web keeper **(7)** the length of the removed keeper and sear ends as described in WP 0013 00.
 - b. Carefully cut and remove stitching **(8)** that secures the loop **(5)** to the harness in two places **(8)** and discard. Cut a 6 1/2-inch length of Type III, CG-483 nylon cord and sear ends as described in WP 0013 00.
 - c. Position nylon cord **(5)** as in original location and stitch with double-throw zigzag or straight zigzag stitching **(8)**, two places forming loop. Use size E thread, 7 to 10 stitches per inch, and a ZZ sewing machine.
 - d. Position web keeper **(7)** 2 1/4-inches from outside edge of loop **(5)** as in original construction. The two plies of web keeper must be located on the loop side of the harness. Stitch with double box X stitch pattern **(6)**. Use size FF thread, 6 to 9 stitches per inch, and a MD sewing machine.

3. Replacement of cord loop "C" (9).
 - a. Carefully cut and remove stitching (10) that secures the cross strap (11) to the harness.
 - b. Carefully cut and remove stitching (12) that secures the loop (9) to the harness in two places (12) and discard. Cut a 5 1/4-inch length of Type III, red nylon cord and sear ends.
 - c. Position nylon cord (9) as in original location and stitch with double-throw zigzag or single-throw zigzag stitching (12), two places forming loop (9). Use size E thread, 7 to 10 stitches per inch, and a ZZ sewing machine.
 - d. Position cross strap (11) 7/8-inch from outside edge of loop with harness strap sandwiched between superimposed cross straps as in original construction and stitch with double box X stitch pattern. Use size 3 thread, 5 to 8 stitches per inch, and a HD sewing machine.

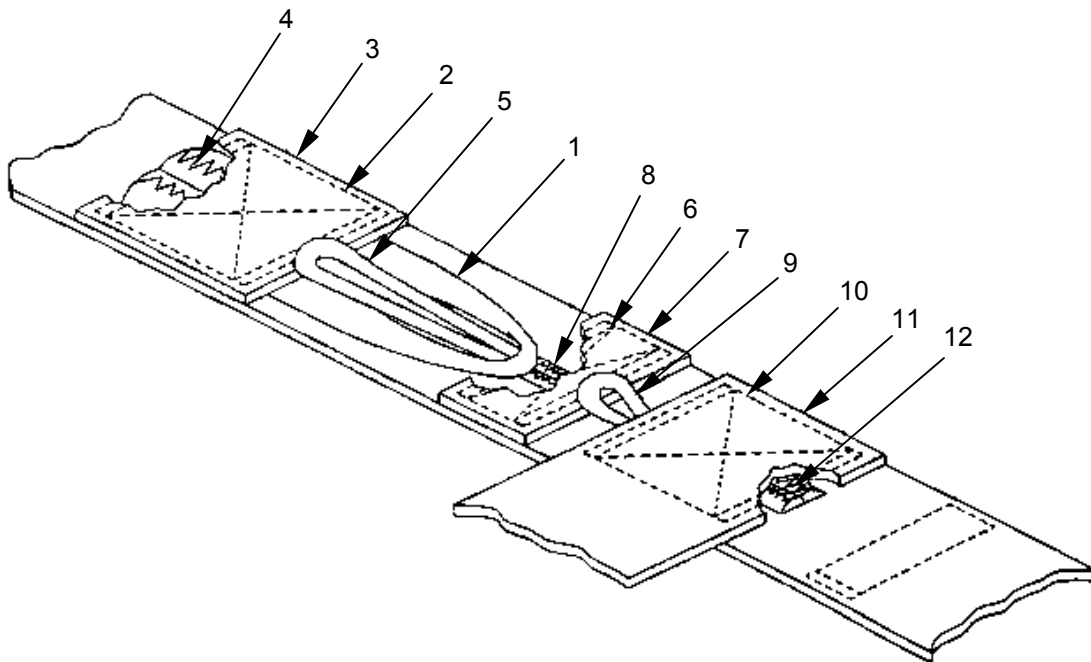

Replace damaged cross straps as follows:

1. Carefully cut and remove without damaging the "C" release loops, the double box X stitching which secures the cross straps **(1)** to the harness **(2)** on both sides.
2. Cut two 8 $\frac{3}{4}$ -inch lengths of Type VIII nylon webbing and sear ends.
3. Cut a 1 $\frac{1}{2}$ -wide X 2-inch long hook tape fastener.
4. On one cross strap, make a mark 4 $\frac{3}{8}$ -inches for the centerline location. From the centerline, make a 1-inch mark at each side.
5. Position replacement 2-inch long hook tape (facing up) between marks and stitch with two rows of box stitching **(3)**. Use size FF thread, 6 to 9 stitches per inch, and a MD sewing machine.
6. Place cross straps **(1)** together with hook tape on inside bottom layer, and with harness strap **(2)** sandwiched between superimposed cross straps as in original construction and stitch with double box X stitch pattern in two places. Use size 3 thread, 5 to 8 stitches per inch, and a HD sewing machine.

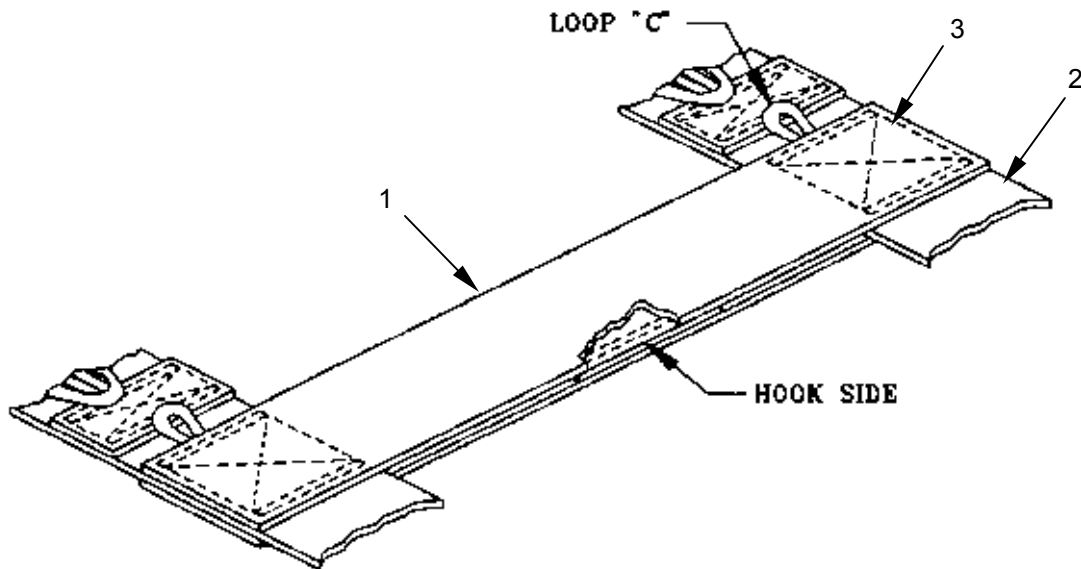

Replace a damaged adjustable cross strap, chape adapter or quick-fit adapter as follows:

1. Replacement of adjustable cross strap **(1)**.
 - a. Carefully cut and remove stitching **(2)** that secures the strap **(1)** to harness **(3)**. Remove adapter **(4)** from strap and discard.
 - b. Cut a 21-inch length of Type VIII nylon webbing and sear ends.
 - c. Position nylon webbing on bottom side of harness **(3)** as in original location and stitch with double box X stitch pattern **(2)**. Use size 3 thread, 5 to 8 stitches per inch, and a HD sewing machine.
 - d. Thread other end of webbing through quick-fit adapter **(4)** and fold end eight times (nine plies thick) 1 1/2-inches wide and stitch with three rows of stitching **(5)** located in the center. Use size 3 thread, 5 to 8 stitches per inch, and a HD sewing machine.
2. Replacement of chape adapter **(6)** or damaged quick-fit adapter **(4)**.
 - a. Carefully cut and remove stitching **(7)** which secures the chape adapter **(6)** to the harness **(3)** and discard chape adapter.
 - b. Cut a 5-inch length of Type VIII nylon webbing, sear ends and fold in center.

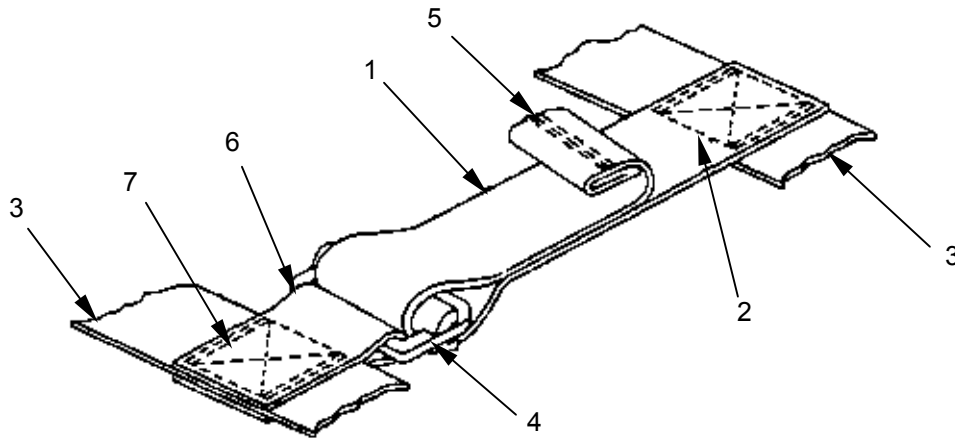

- c. Unthread folded end of adjustable strap (1) from quick-fit adapter (2).
- d. Place serviceable quick-fit adapter (4) on new chape adapter (6) with harness strap (3) sandwiched between superimposed web chape adapter (6) as in original construction and stitch with double box X stitch pattern (7). Use size 3 thread, 5 to 8 stitches per inch, and a HD sewing machine.

Replace a damaged Attaching Harness Strap (1) with a serviceable item from stock.

1. Replacement of damaged hardware:

- a. If only the snap hook (2) is damaged, carefully cut and remove the stitching at the folded end of the strap (3). Remove damaged snap hook and replace with serviceable item. Fold end of strap according to original construction and stitch using size 3 thread, 5 to 8 stitches per inch, and a HD sewing machine.
- b. If only the triangular link (4) is damaged, carefully cut and remove the stitching at the folded end of the strap (3), sides and link end (5) of the strap. Remove triangular link and replace with a serviceable item. Stitch link end (5) and sides. Fold end of strap as in the original construction and stitch using size 3 thread, 5 to 8 stitches per inch, and a HD sewing machine.

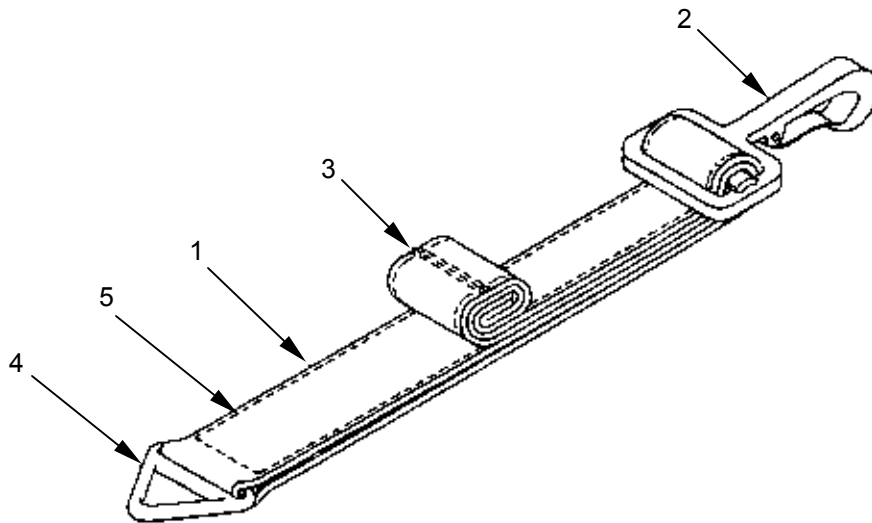

Replace a damaged cross adjustable leg strap by fabricating a new one as described in WP 0053 00.

1. Replacement of damaged quick release buckle:
 - a. If only the male half quick release buckle (1) is damaged, carefully cut and remove the stitching at the folded end of the strap (2). Remove male half of buckle, replace with a serviceable item of like construction and design.
 - b. Thread through replacement buckle as in original construction and fold end (3) four times (five plies thick) 1-inch wide and stitch with double box stitch pattern using size 3 thread, 5 to 8 stitches per inch, and a HD sewing machine.

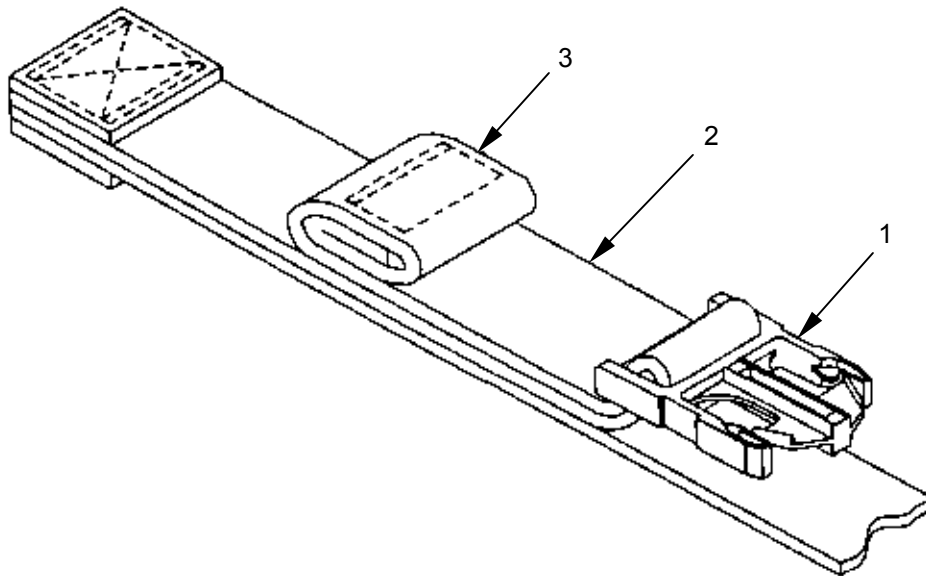

Replace a damaged Leg Strap Release Assembly with a new one.

1. Replacement of damaged elastic keeper (1).
 - a. Carefully cut and remove stitching (2) that secures the keeper to the strap.
 - b. Cut a 4 ³/₄-inch length of 1-inch wide elastic webbing and wax dip ends to a depth of ³/₈-inch.
 - c. Fold in half with ends aligned and stitch with two rows of stitching ¹/₂-inch from edge (3). Use size FF thread, 6 to 9 stitches per inch, and a MD sewing machine.
 - d. With keeper (1) turned to inside, position in original location and stitch to strap with two rows of stitching ¹/₄-inch from edge. Use size FF thread, 6 to 9 stitches per inch, and a MD sewing machine. Turn keeper to outside by passing end of leg strap release assembly through keeper loop.
2. Replace or reset a loose or damaged grommet (4) in accordance with procedures described in WP 0015 00.
 - a. Resetting. Reset a loose Size 0, Type III Spur Grommet and washer by using appropriate dies.
 - b. Replace. Remove damaged grommet and washer by cutting it with a pair of diagonal wire cutters. Do not damage the webbing.
 - c. Set. Without damage to the webbing, install a replacement grommet of appropriate size, and set using the proper size dies. The grommet half shall be located on the web loop side of the leg strap release assembly.

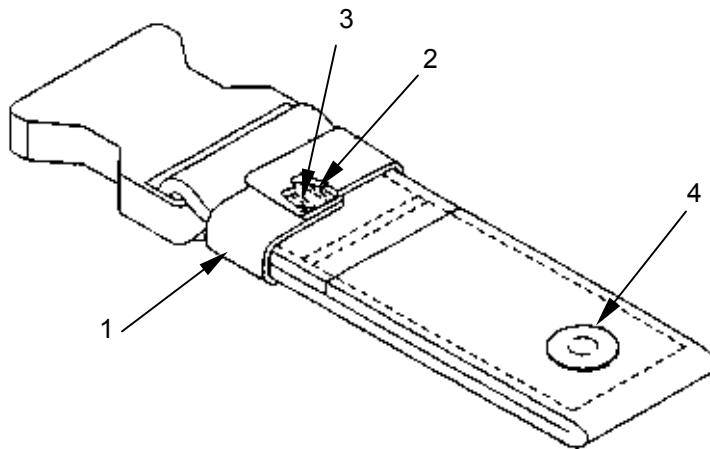

Release Handle Assembly. Replace a damaged cable lanyard or pile fastener tape on the release handle assembly as follows:

1. Replacement of release handle lanyard **(1)**.
 - a. Cut the tubular lanyard web adjacent to harness **(2)** and handle straps **(3)** and discard.
 - b. Cut a 9 ³/₄-inch length of ⁵/₈-inch width, natural color tubular webbing and sear ends.
 - c. Position replacement on top of webbing (side opposite the pile tape) to outside edge of webbing and secure to handle assembly using double box stitch pattern **(4)**. Use size 3 thread, 5 to 8 stitches per inch, and a HD sewing machine.
 - d. Superimpose other end of replacement on top of cut lanyard, to outside edge of webbing and secure to harness assembly with double box stitch pattern **(5)**. Use size 3 thread, 5 to 8 stitches per inch, and a HD sewing machine.
2. Replacement of pile fastener tape **(6)**.
 - a. Carefully cut and remove stitching **(7)** that secures the pile to the release handle and discard.
 - b. Cut a 1 ³/₄-inch length of 1 ¹/₂-inch width pile tape.
 - c. Position as in original location and stitch with two rows of stitching ¹/₈-inch from the edges. Use size FF thread, 6 to 9 stitches per inch, and a MD sewing machine.

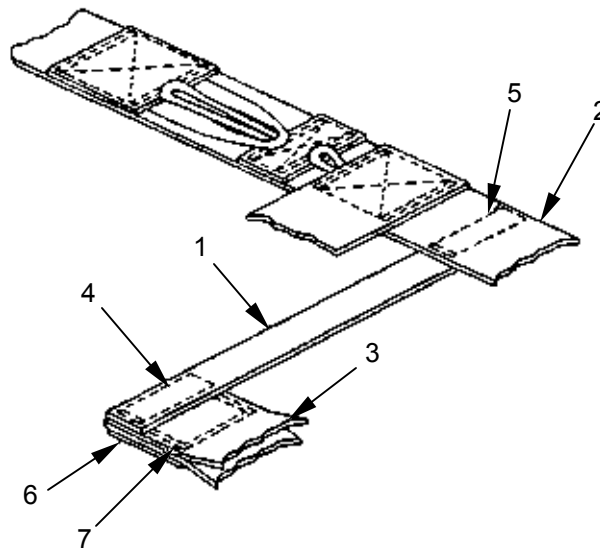

3. Replace or reset a loose or damaged wire cable on the release handle assembly as follows:
 - a. Re-press a loose cable sleeve (1) with compressing tool.
 - b. Replacement of damaged wire cable.
 - (1) Remove a damaged wire cable by cutting cable at web loop attachment (2) location with cable cutter.
 - (2) Cut a 17-inch length of replacement cable and sear ends of the nylon cable cover coating, sealing the ends of the wire material.

CAUTION

Be careful not to cut the wire cable material by compressing the sleeve excessively tight when assembling sleeve to the cable.

- (3) Thread one end of cable through the $\frac{3}{4}$ -inch long wire cable sleeve (1), web loop of handle assembly (2), and opposite side of sleeve until ends are even, forming a 1-inch loop from cable edge to sleeve edge. Compress the sleeve $\frac{3}{16}$ -inch from each end of the sleeve (two places) firmly to retain cable. The cable legs shall be positioned between the web plies and to the outside edges of pile tape stitching (3).

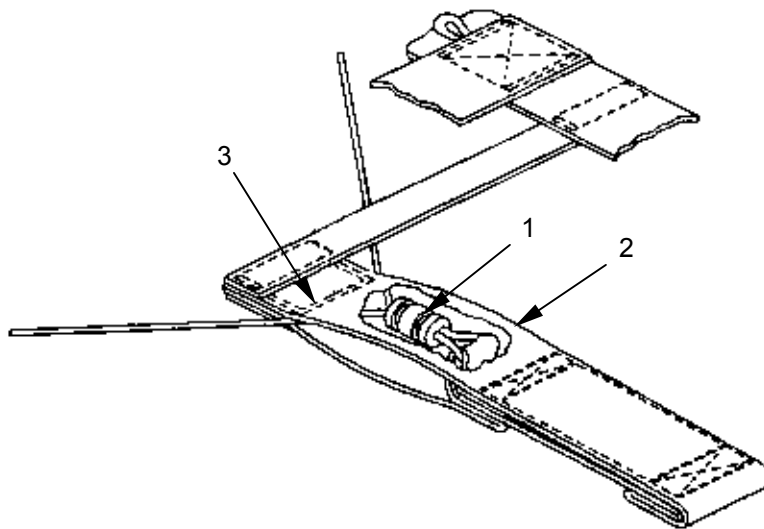

Replace damaged retainer strap quick-fit adapters as follows:

1. Carefully cut and remove the 4-point WW stitch pattern **(1)** which secures the adapter to the harness and discard buffer **(2)**.
2. Cut a 3 1/2-inch length of Type VIII nylon webbing, sear ends and fold so ends are offset 1/4-inch.
3. Position buffer **(2)** and harness web strap on serviceable adapter as in original and stitch with 3-inch long 4-point WW stitch pattern. Use size 3 thread, 5 to 8 stitches per inch, and a HD sewing machine.

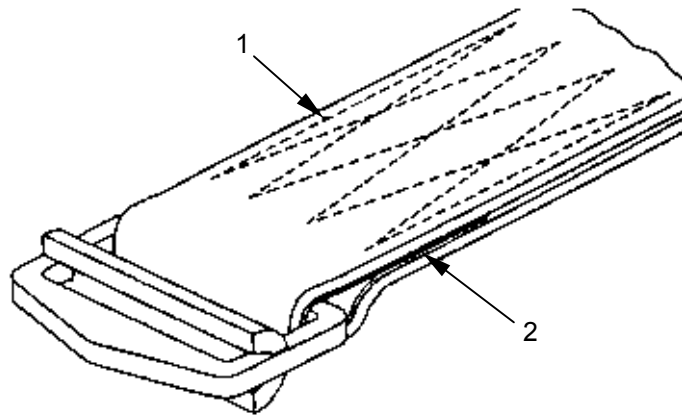

END OF WORK PACKAGE

ANCILLARY EQUIPMENT FOR PERSONNEL PARACHUTE SYSTEM

**PACK ASSEMBLY, AT4
INSPECT, REPAIR, REPLACE**

INITIAL SETUP:

Tools

Knife (WP 0034 00, Table 2, Item 6)
Shears (WP 0034 00, Table 2, Item 20)
Sewing Machine, HD (WP 0034 00, Table 2, Item 16)
Sewing Machine, Darning (WP 0034 00, Table 2, Item 15)
Sewing Machine, MD (WP 0034 00, Table 2, Item 18)

Personnel Required

92R(10) Parachute Rigger

Materials/Parts

Beeswax, technical (WP 0052 00, Table 1, Item 1)
Brush, Stencil (WP 0052 00, Table 1, Item 3)
Cloth, Nylon, 12.5 oz (WP 0052 00, Table 1, Item 9)
Felt, 1/4-inch (WP 0052 00, Table 1, Item 17)
Ink, Marking (WP 0052 00, Table 1, Item 21)
Stencilboard, Oiled (WP 0052 00, Table 1, Item 29)
Tape, fastener, pile (WP 0052 00, Table 1, Item 36)
Tape, cotton, 1-inch (WP 0052 00, Table 1, Item 43)
Thread, nylon, size 3 (WP 0052 00, Table 1, Item 47)
Thread, nylon, size E (WP 0052 00, Table 1, Item 50)
Thread, nylon, size FF (WP 0052 00, Table 1, Item 51)
Wax, Paraffin, Type I, technical (WP 0052 00, Table 1, Item 52)
Webbing, nylon, type VII, 1 ⁹/₁₆-inch wide (WP 0052 00, Table 1, Item 64)
Webbing, nylon, type VIII (WP 0052 00, Table 1, Item 61)

Equipment Condition

The AT4 Pack should be clean and dry. Place assembly on worktable.

INSPECT

Perform a before and after technical/rigger type inspection of the AT4 Pack as outlined in WP 0008 00.

REPAIR

The nylon fabric (1) of the pack body may be restitched, darned and patched. The felt lining may be restitched and plugged.

1. Restitching. Restitch loose or broken stitching on body of pack (2), muzzle butt (3), and lowering line pocket (4) directly over old stitching using size 3 thread, 5 to 8 stitches per inch, and a HD sewing machine. Lock stitching at least $\frac{1}{2}$ -inch.

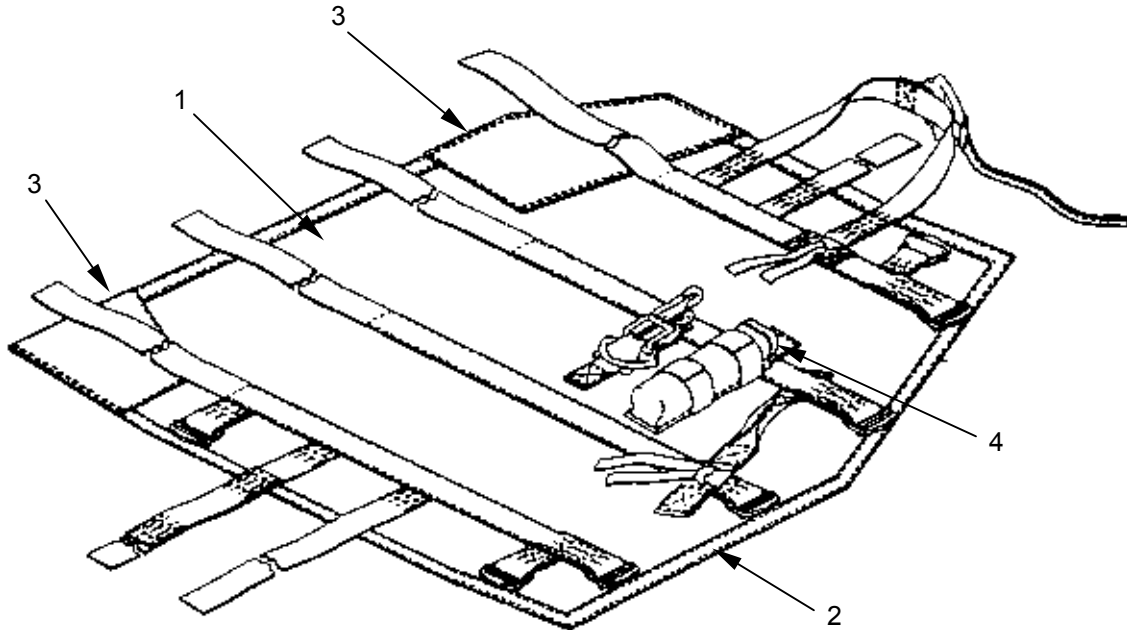

2. Darning. Darn a hole or tear in the pack fabric, rifle butt or muzzle pockets that does not exceed 1-inch in length or diameter using size E thread and a darning machine. There is no limit to darns that may be applied, provided they do not weaken or reduce the original strength of the fabric more than 10%. If damage is in the lined portion of the container body and only the cotton duck is damaged, darn through duck and felt. If felt is also damaged, remove damaged area before darning duck fabric. Then plug felt as in 3(c) below.
3. Patching. There is no limit to the number of times the container body may be patched. Patch a hole or tear that exceeds 1-inch in length or diameter following procedures in (a) or (b) below. Use nylon or cotton duck cloth according to original construction for patching outside, and $\frac{1}{4}$ -inch thick felt for plugging inside lining. Use a HD sewing machine, size 3 thread, and 5 to 8 stitches per inch.

- a. To patch a lined portion of the pack (1) when the felt (2) is not damaged, cut nylon or cotton duck patch (3) 2-inches beyond circumference of damaged portion. Turn under edges of patch $\frac{1}{2}$ -inch and center patch over damaged area. Sew patch to pack (1) with a double row of stitching (4) as shown.

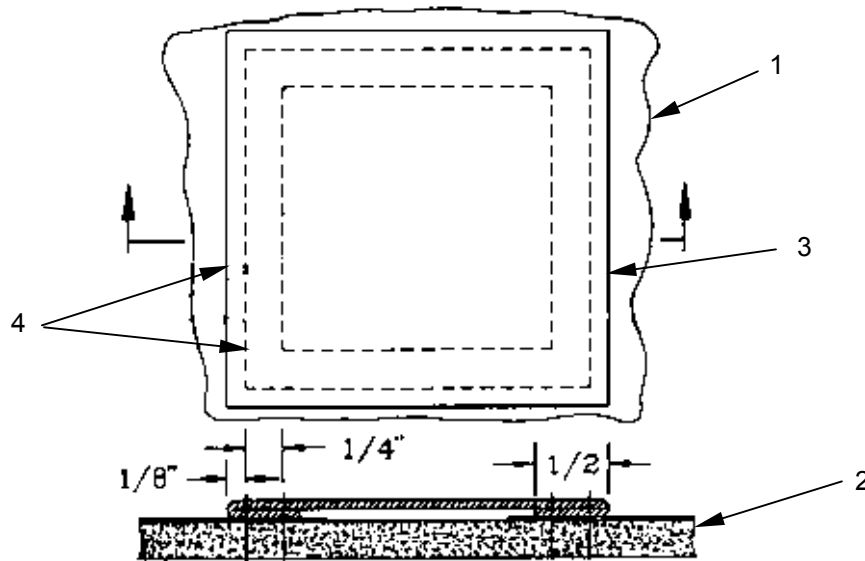

- b. To patch a lined portion of the pack (1) when the felt (2) is damaged, remove the damaged felt as described in (3) below. Cut a piece of felt (2) the same size as the piece removed, and position felt plug and cotton duck patch (3) (with edges turned under $\frac{1}{2}$ -inch) over damaged area. Sew a single box X stitch (4) formation as shown.

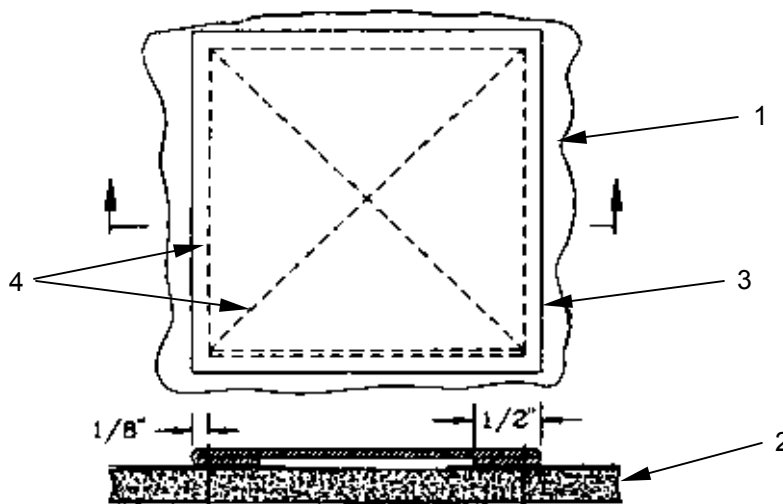

- c. To plug the felt (1) lining, mark a rectangle around the damaged area. Remove the damaged felt while being careful not to damage the cotton duck material (2). If damage is in area of the rifle butt or muzzle pockets, carefully remove stitching that holds pocket to pack. Cut a piece of felt the size of the piece removed. Position felt plug into area cleared and sew as shown. Use size 3 thread, 5 to 8 stitches (3) per inch and a HD sewing machine.

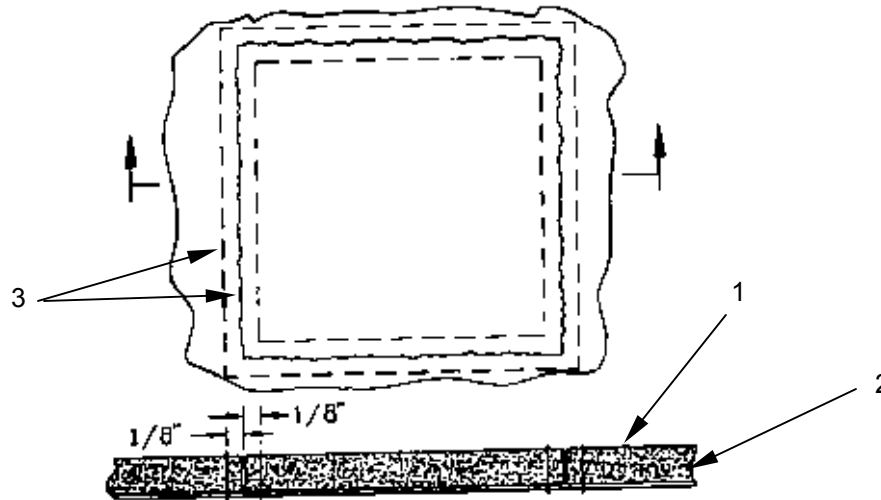

- d. Repair of binding tape. Overlap the binding tape extending the new tape at least 1-inch beyond the damaged tape. Stitch tape with two rows of stitching 1/8 and 1/4-inches from edge of tape as in original construction using size 3 thread, 5 to 8 stitches per inch and a HD sewing machine.
- e. Repairing Webbing.

CAUTION

If the webbing is inadvertently damaged when stitching is being removed, the webbing must be replaced in accordance with original construction.

- (1) General. The webbing on the pack may be restitched.
 - (2) Restitching. Restitch loose, broken or defective stitching according to original construction using size 3 thread, 5 to 8 stitches per inch and a HD sewing machine. Lock stitching at least 1/2-inch.
- f. Repair lowering line pocket (3) by restitching. Use size FF thread, 6 to 9 stitches per inch, and a MD sewing machine. Lock stitching at least 1/2 inch.

CAUTION

Splicing of the lowering line is not authorized. Serious equipment damage may occur due to failure of a spliced lowering line.

- g. Repair lowering line (2) by restitching. Use size 3 thread, 5 to 8 stitches per inch and a MD sewing machine. Lock stitching at least 1/2-inch. To replace quick ejector snap, carefully cut and remove stitching that holds hardware to lowering line. Place new ejector snap between buffer and lowering line and stitch using size 3 thread, 5 to 8 stitches per inch and a HD sewing machine.

REPLACE

Lowering Line Pocket. Replace a damaged lowering line pocket, and hook and pile retainer as follows:

1. Cut stitching (1) and remove damaged pocket (2) from pack.
2. Fabricate a new lowering line pocket as described in WP 0053 00.
3. Position replacement pocket assembly as in original and stitch to pack $\frac{1}{8}$ -inch from pocket edge (3) using size 3 thread, 5 to 8 stitches per inch and a HD sewing machine.

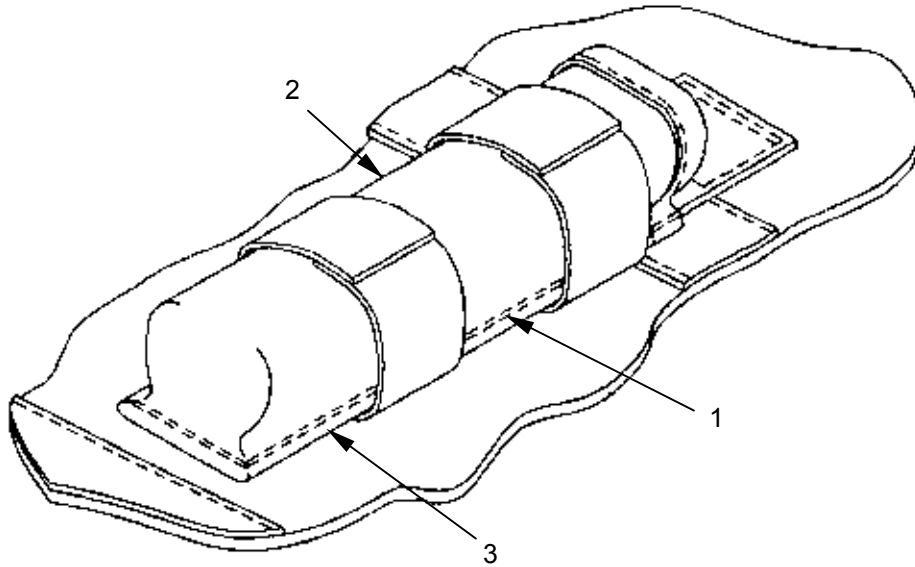

Replacing Webbing. All webbing items may be replaced. Replacement will be accomplished in accordance with the original construction and as prescribed herein.

1. Line/D-Ring Chape. Replace damaged chape as follows:
 - a. Carefully cut and remove the three stitch patterns that secure the chape **(1)** to the pack and discard.
 - b. Make new chape as specified in WP 0053 00.
 - c. Position replacement chape as in original and secure to pack body with 2-inch double box X stitch pattern in center of chape using size 3 thread 5 to 8 stitches per inch and a HD sewing machine.
 - d. Position serviceable link **(2)** in location and direction as in original and secure to pack with 2-inch double box X stitch pattern using size 3 thread 5 to 8 stitches per inch and a HD sewing machine.
 - e. Position serviceable D-ring **(3)** in location as in original and secure to pack with 2-inch double box X stitch pattern using size 3 thread 5 to 8 stitches per inch and a HD sewing machine.

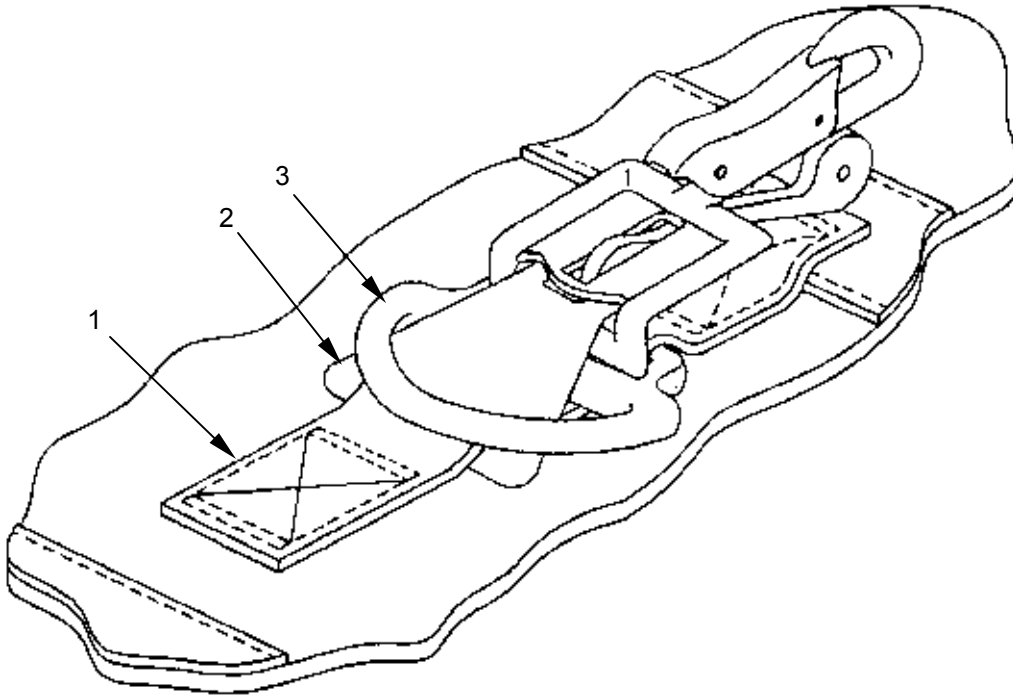

2. Carrying Handle Strap. Replace damaged carrying handle strap as follows:
 - a. Remove damaged handle by cutting and removing stitching (1) of the two 2-inch box X patterns which secure the handle (2) to the pack at the leg tiedown tape end (3). Cut the webbing along the side-securing strap (4) at the other end and discard.
 - b. Make new handle as specified in WP 0053 00.
 - c. Turn under ends 1 1/4-inch and position replacement strap on top of side securing strap over cut end of old carrying handle, and over other end as in original construction using size 3 thread 5 to 8 stitches per inch and a HD sewing machine.

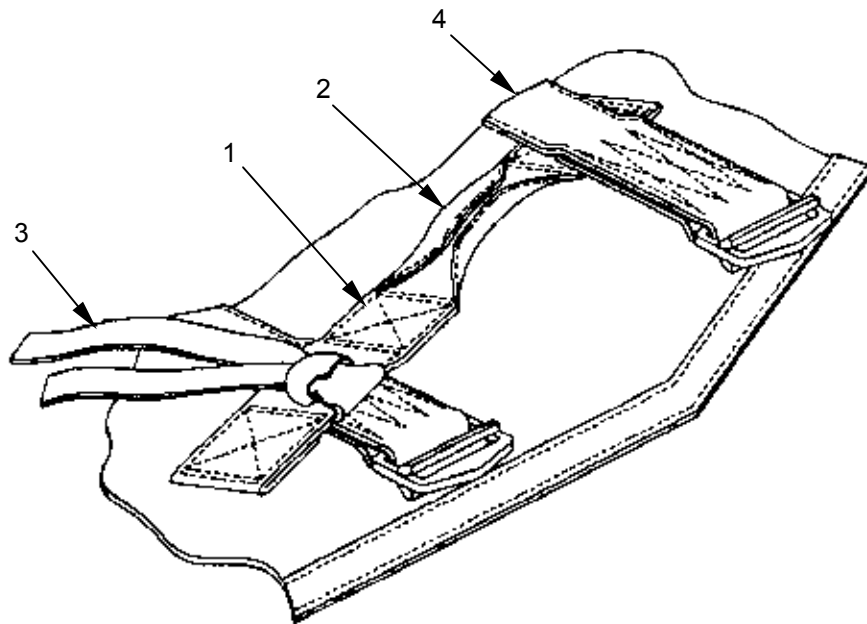

3. Side securing strap-running ends. Replace damaged running end of side securing strap as follows:
 - a. Remove damaged end by cutting strap along stitching that secures it to the pack.
 - b. Cut a length of Type VIII nylon webbing equal to length removed plus 3 1/2-inches and sear ends.
 - c. Turn under one end 1/2-inch, and position replacement strap 3 inches beyond the cut webbing end on the pack. Stitch with 3-inch four point WW pattern using size 3 thread 5 to 8 stitches per inch and a HD sewing machine.

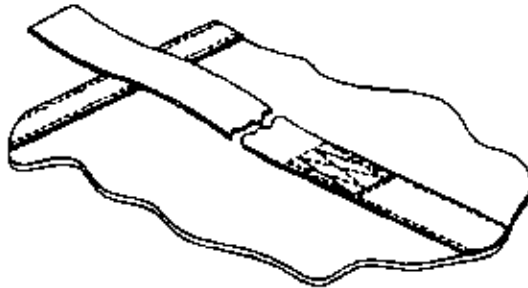

4. Aft end securing straps. Replace damaged aft securing straps as follows:
 - a. Remove damaged end by cutting strap (1) along stitching (2) that secures strap to pack (3).
 - b. Cut a length of Type VII nylon webbing to length removed plus 3-inches and sear ends of webbing.
 - c. Position replacement strap 3-inches beyond the cut webbing end on the pack (3). Stitch with 3-inch four point WW using size 3 thread 5 to 8 stitches per inch and a HD sewing machine.

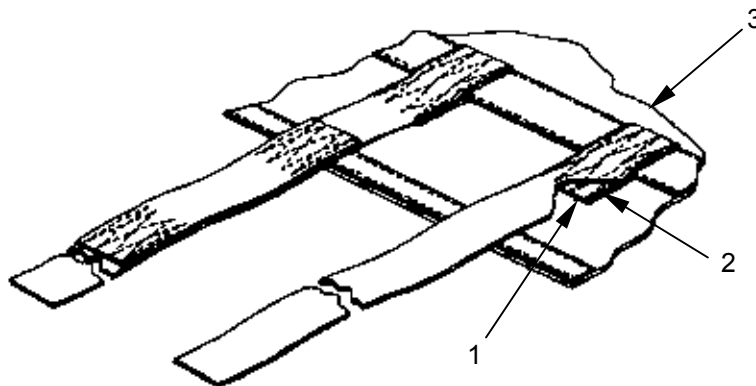

5. Replacement of damaged keeper strap:
 - a. Carefully cut and remove stitching which secures the keeper (1) to the aft end securing strap (2) and discard.
 - b. Cut a 13-inch length of Type VII nylon webbing and sear ends.
 - c. Make a mark 3-inches from each end for the 3-inch stitch patterns (3).
 - d. Position replacement keeper as in original and secure to strap with 3-inch four point WW patterns using size 3 thread 5 to 8 stitches per inch and a HD sewing machine.

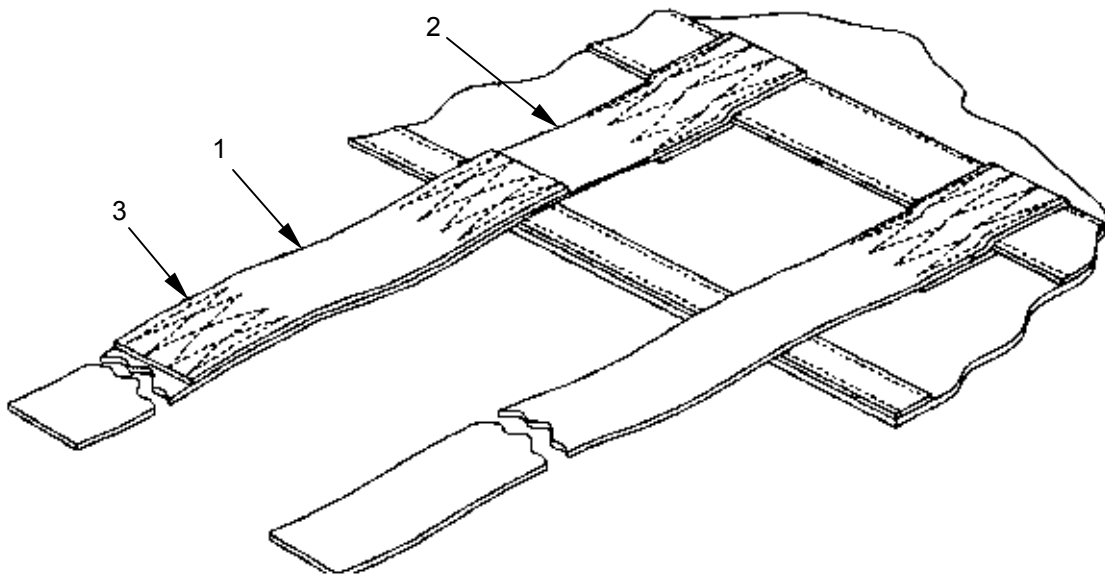

6. Quick-Fit Adapter Chape, Side and Aft Securing Adapters. Replace damaged webbing or adapter as follows:
 - a. Remove adapter by cutting webbing as close to stitching as possible **(1)** and discard.
 - b. Cut a 3 ³/₄-inch buffer of Type VIII nylon webbing and fold so ends are offset ¹/₂-inch **(2)**.
 - c. Cut a 7 ¹/₂-inch adapter chape of Type VIII nylon webbing and sear ends. Fold webbing ¹/₂ and 3 ³/₄-inches from one end.
 - d. Place buffer and chape on serviceable adapter **(3)** and position replacement on top of original. Sew with a 3-inch 4-point WW stitch formation using size 3 thread 5 to 8 stitches per inch and a HD sewing machine.

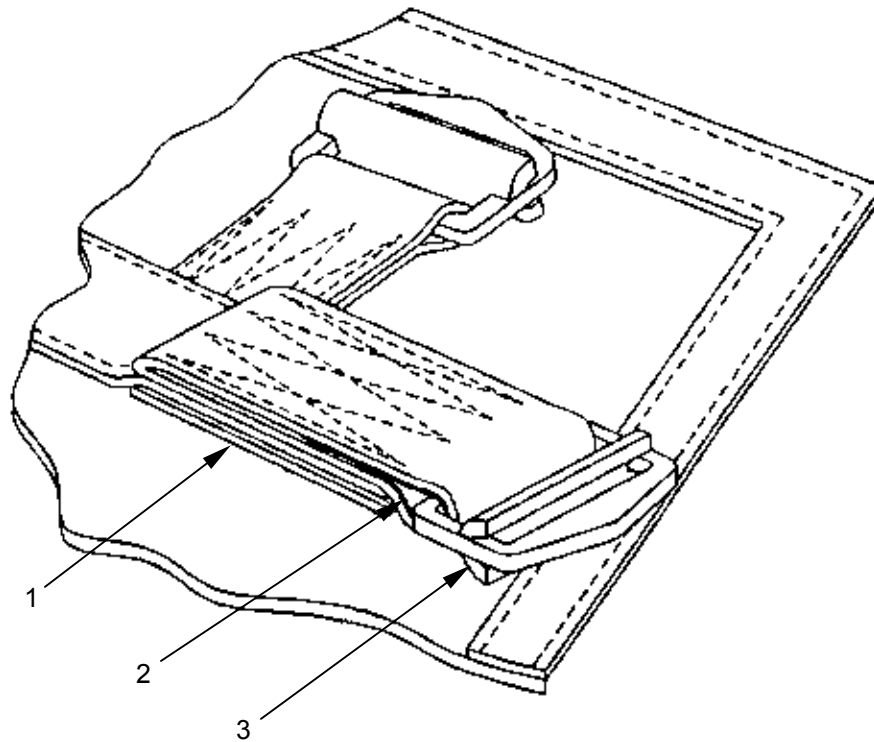

7. Forward end cross strap. Replace damaged cross strap as follows:
 - a. Carefully cut and remove stitching (1) of the two 4-point patterns which secures the strap (2) to the pack body and discard.
 - b. Make new forward end cross strap in accordance with WP 0053 00.
 - c. Position replacement cross strap with "D" ring (3) as in original and secure to pack using two 3 1/2-inch 4-point WW stitch pattern (1) using size 3 thread 5 to 8 stitches per inch and a HD sewing machine.
8. Forward end securing strap. Replace damaged forward securing strap as follows:
 - a. Carefully cut and remove stitching (4) which secures the strap (5) to the pack body and discard.
 - b. Cut a 20-inch length of Type VII nylon webbing and sear ends and make a mark 3 1/2-inches at one end (4) for the stitch pattern.
 - c. Position replacement securing strap as in original and secure to pack using 3 1/2-inch 4-point WW stitch pattern as shown, using size 3 thread 5 to 8 stitches per inch and a HD sewing machine.

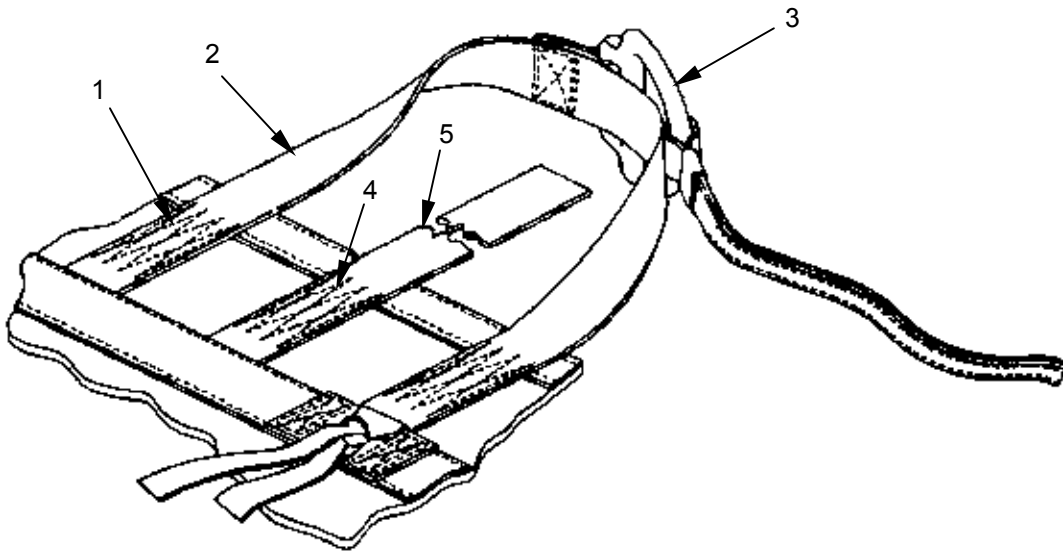

9. Leg Tiedown Tape. Replace a damaged or missing tiedown tape as follows:
 - a. Remove the tiedown by untying the slip loop (girth hitch) knot and discard.
 - b. Cut an 82-inch length of 1-inch wide, Type II, cotton tape and wax dip cut ends a minimum of $\frac{1}{2}$ -inch.
 - c. Fold tape so one end is twice as long as the other. Pass loop through leg tiedown loop, forming a slip loop (girth hitch) knot around webbing.
10. Upper tiedown chape. Replace damaged web chape as follows:
 - a. Carefully cut and remove stitching (1) which secures the chape (2) to the side securing strap (3), pack body and discard.
 - b. Cut a 5 $\frac{1}{4}$ -inch length of Type VIII nylon webbing, sear ends, and fold the ends $\frac{7}{8}$ -inch (3).
 - c. Position replacement chape as in original and secure to side securing strap (2) and pack body with $\frac{5}{8}$ -inch double box X stitch pattern using size 3 thread 5 to 8 stitches per inch and a HD sewing machine.

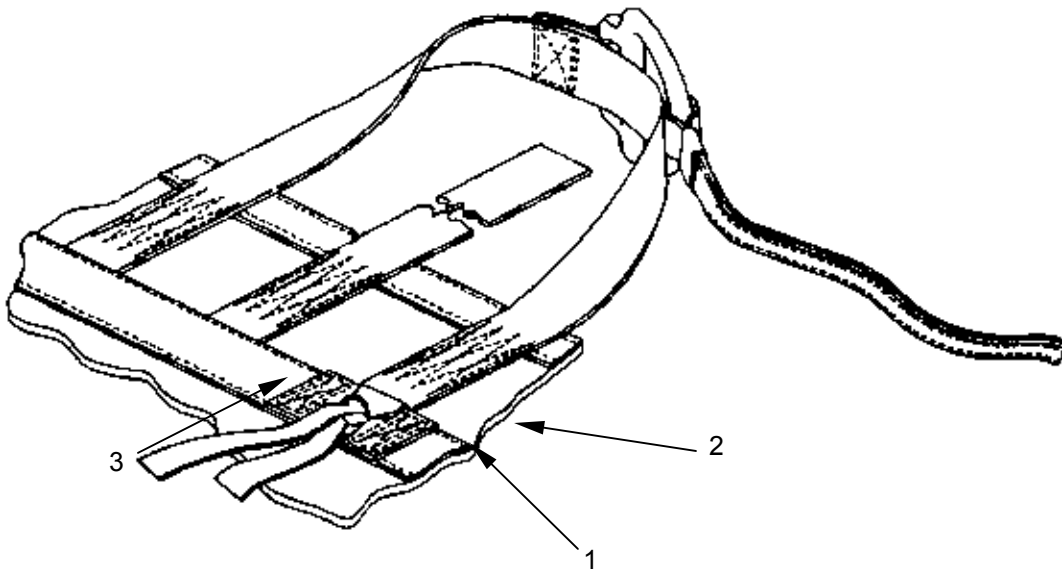

Replacing hardware.

1. The quick-ejector snap on the lowering line may be replaced when damaged, by carefully cutting the stitching that secures hardware to lowering line. Place buffer and lowering line on serviceable quick-ejector snap and stitch with 3-inch, 3-point WW stitch formation using size 3 thread 5 to 8 stitches per inch and a HD sewing machine.
2. Replace other damaged hardware by carefully cutting and removing the two end stitch patterns that secures the hardware to the pack. Replace with serviceable link or D-ring by positioning as in original and sewing with 2-inch double box X stitch pattern using size 3 thread 5 to 8 stitches per inch and a HD sewing machine.

Alteration of Line Assembly, Lowering, for Tandem Load.

WARNING

This alteration applies only to loads used with tandem loads. Each commander will be responsible for determining the support operation requirement for his/her command, alter only the quantity necessary to support operation requirements.

1. Carefully cut the stitching that secures the 2-inch long pile tape located approximately 11 ³/₄-inch from quick-ejector snap end and remove cut stitching.
2. Cut a 2-inch length of pile tape. (If previously removed pile tape is undamaged, it may be used in lieu of replacement tape.)
3. Place marks 46 and 48-inches from the folded web edge quick-ejector snap end on the side of the removed 2-inch pile tape of the 1-inch wide lowering line.
4. With pile side facing up, position 2-inch pile tape between the marking and stitch with a single box stitch using size E thread, 7 to 11 stitches per inch and a MD sewing machine.
5. Markings.
 - a. Stencil with ¹/₂ inch high characters, on the outside of retainer fabric using stencil brush and parachute marking blue ink the following "DMJP/AT4JP MOD."
 - b. Stencil ¹/₈-inch wide line across the web width on each side of lowering line, 187-inches from fold web edge quick-ejector snap end.

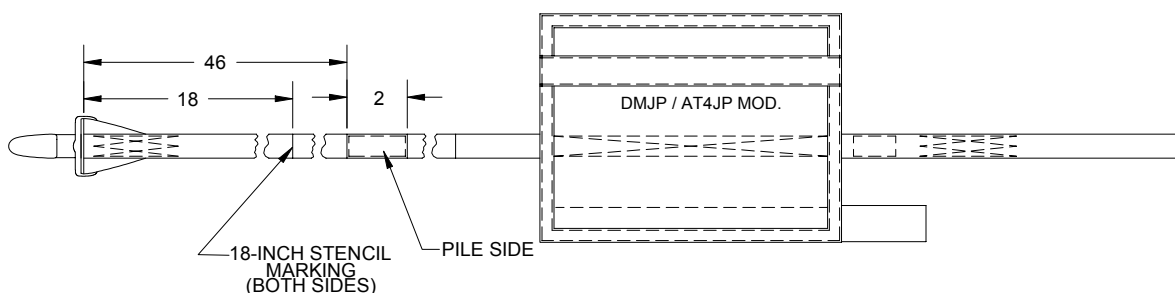

END OF WORK PACKAGE

ANCILLARY EQUIPMENT FOR PERSONNEL PARACHUTE SYSTEM

**CASE, PARACHUTIST'S INDIVIDUAL WEAPON M-1950 (COTTON)
INSPECT, REPAIR, REPLACE**

INITIAL SETUP:

Tools

Knife (WP 0034 00, Table 2, Item 6)
Shears (WP 0034 00, Table 2, Item 20)
Sewing Machine, HD (WP 0034 00, Table 2,
Item 16)
Sewing Machine, MD (WP 0034 00, Table 2,
Item 18)

Personnel Required

92R(10) Parachute Rigger

Materials/Parts

Beeswax, technical (WP 0052 00, Table 1, Item
1)
Cloth, duck, cotton, Type I (WP 0052 00, Table
1, Item 7)
Felt, 1/4-inch (WP 0052 00, Table 1, Item 17)
Ink, marking, parachute, strata-blue (WP 0052
00, Table 1, Item 21)
Leather, cattlehide (WP 0052 00, Table 1, Item
22)
Lubricant, Stick form (WP 0052 00, Table 1,
Item 24)
Tape, cotton, 3/4-inch, Type I (WP 0052 00,
Table 1, Item 41)
Thread, size 3 (WP 0052 00, Table 1, Item 47)
Thread, nylon, size 5 (WP 0052 00, Table 1,
Item 48)
Thread, nylon, size FF (WP 0052 00, Table 1,
Item 51)
Wax, Paraffin, Type I, Technical (WP 0052 00,
Table 1, Item 52)
Webbing, cotton, type III (WP 0052 00, Table 1,
Item 54)
Webbing, cotton, type VIII (WP 0052 00, Table
1, Item 56)

Equipment Condition

Parachutist's Weapon's and Individual
Equipment Pack and Harness Assembly should
be clean and dry. Place assembly on
worktable.

INSPECT

Perform a before and after technical/rigger type inspection of the cotton M-1950 Weapons Case as outlined in WP 0008 00.

NOTE

The cotton M-1950 is no longer logistically supported both as an item and repair parts. Once the cotton M-1950 is considered beyond being economically repaired, replace it with a new nylon M-1950 from stock.

REPAIR

The cotton duck (1) and felt (2) fabric of the case may be restitched, darned, patched and plugged.

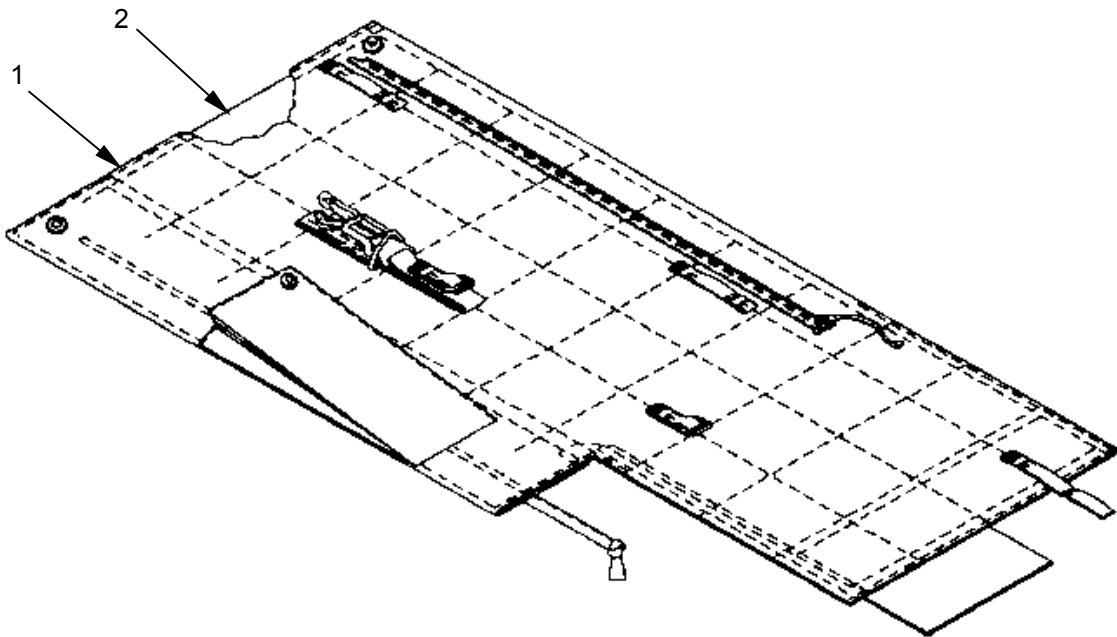

1. Restitching. Restitch the case fabric (1) directly over old stitching using size 5 thread, 4 to 6 stitches per inch, and a HD sewing machine. Lock stitching at least $\frac{1}{2}$ -inch.
2. Darning. Darn a hole or tear in the case fabric that does not exceed 1-inch in length or diameter using size E thread and a darning machine. There is no limit to darns that may be applied, provided they do not weaken or reduce the original strength of the fabric more than 10%. If damage is in the lined portion of the case and only the cotton duck is damaged, darn through duck and felt. If felt is also damaged, remove damaged area before darning duck fabric. Then plug felt as in 3. c) below.
3. Patching. There is no limit to the number of times the case may be patched. Patch a hole or tear that exceeds 1-inch in length or diameter following procedures in a) or b) below. Use nylon or cotton duck cloth according to original construction for patching outside, and $\frac{1}{4}$ -inch thick felt for plugging inside lining. Use a MD sewing machine, size FF thread, and 6 to 9 stitches per inch.

- a. To patch a lined portion of the case (1) when the felt (2) is not damaged, cut nylon or cotton duck patch (3) 2-inches beyond circumference of damaged portion. Turn under edges of patch $\frac{1}{2}$ -inch and center patch (3) over damaged area. Sew patch to case with a double row of stitching (4) as shown.

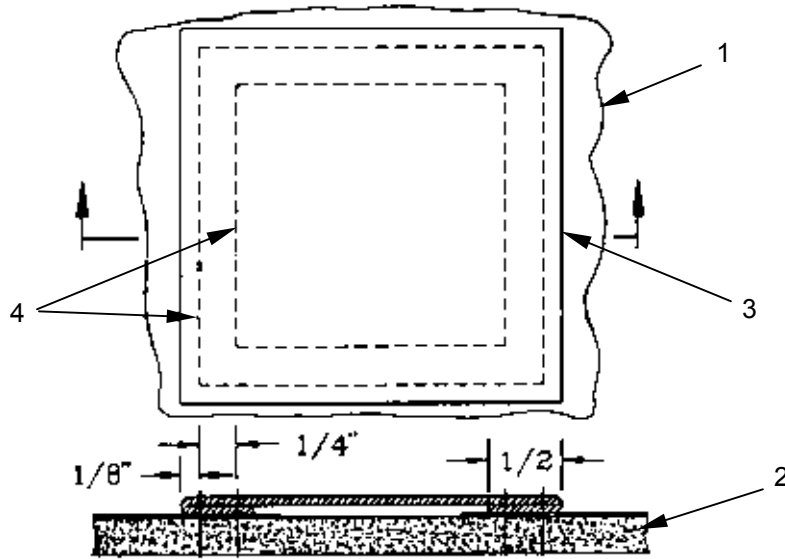

- b. To patch a lined portion of the case (1) when the felt (2) is damaged, remove the damaged felt as described in c) below. Cut a piece of felt the same size as the piece removed, and position felt plug and cotton duck patch (3) (with edges turned under $\frac{1}{2}$ -inch) over damaged area. Sew a single box X stitch (4) formation as shown.

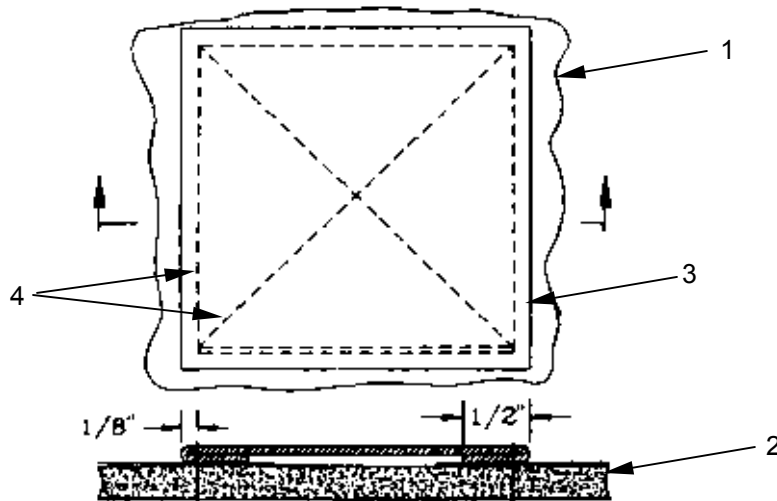

- c. To plug the felt (1) lining, mark a rectangle around the damaged area. Remove the damaged felt while being careful not to damage the cotton duck material (2). Cut a piece of felt (1) the size of the piece removed. Position felt plug into area cleared and sew as shown. Use size 3 thread, 5 to 8 stitches (3) per inch and a HD sewing machine.

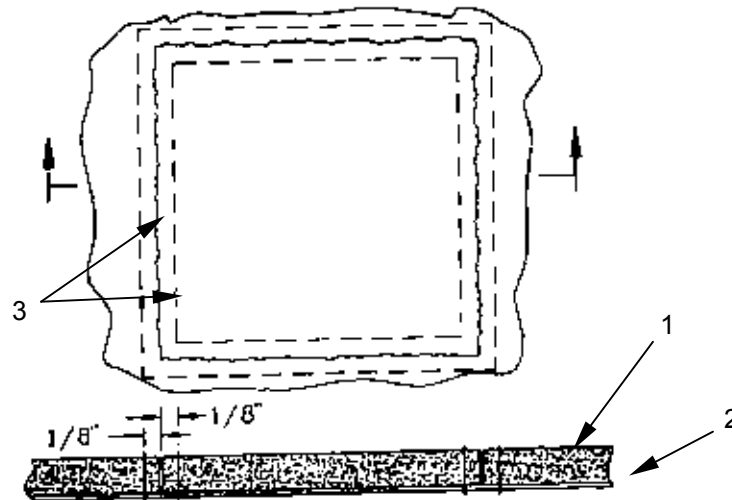

- d. Repairing Tape, Webbing and Leather. Restitching is the only repair authorized for the tape, webbing, and leather items on the weapons case. Restitch loose or broken stitching on the corner reinforcement, tiedown loops, quick-adjustable buckle loop and shock absorber loop using size 3 thread, 5 to 8 stitches per inch and a HD sewing machine. Restitch flap thong, and slide fastener thong, using size FF thread, 6 to 9 stitches per inch and a MD sewing machine. Restitch the leather reinforcement using size 5 thread, 4 to 6 stitches per inch and a HD sewing machine. Backstitch at least 1/2-inch.
- e. Repairing and Lubricating Slide Fastener. Restitch loose or broken stitching on slide fastener tape using size FF thread, 6 to 9 stitches per inch and a MD sewing machine. Apply a small amount of "zipper ease" lubricant to slide fastener when it becomes difficult to operate.

REPLACE

Replace the lowering line pocket (1) as follows:

1. Cut stitching (2) and remove damaged pocket.
2. Fabricate a new pocket as specified in WP 0053 00.

CAUTION

Avoid sewing through slide fastener when attaching new lowering line pocket. Damage to the slide fastener will result.

3. Position new pocket on weapons case (3), turn edges under $\frac{1}{2}$ -inch, and sew pocket to case using size 3 thread, 5 to 8 stitches per inch and a HD sewing machine.

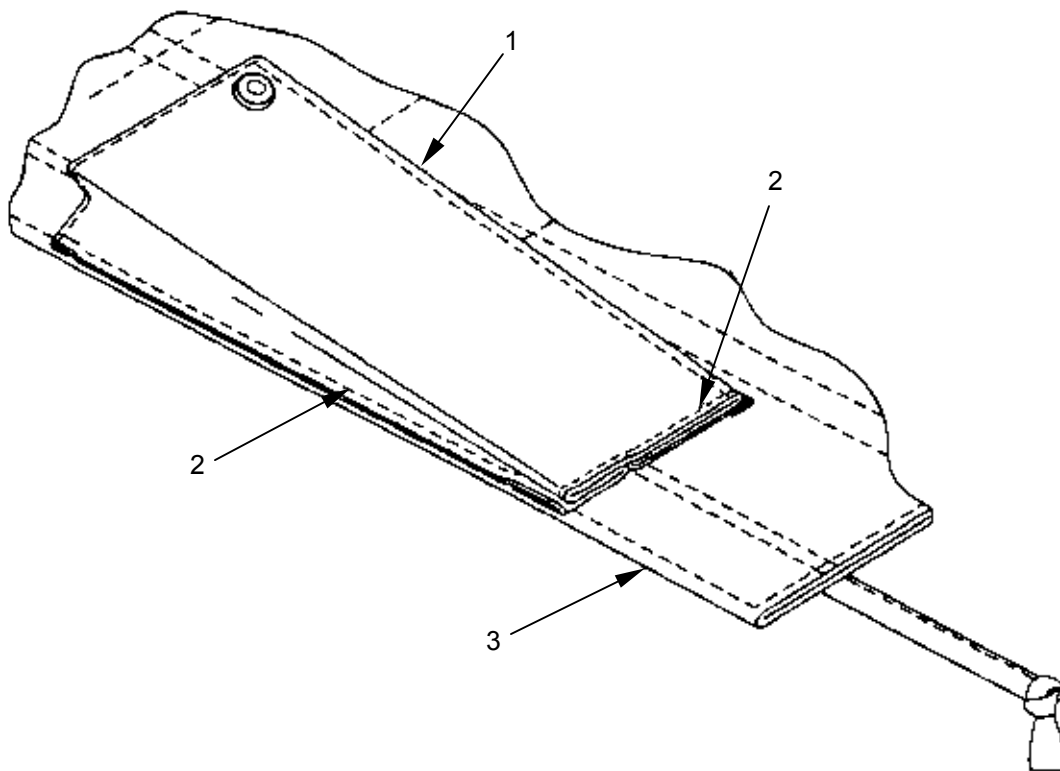

Replace the strip panel (1) as follows:

1. Cut stitching (2) and remove damaged strip panel (1) from weapons case (3).
2. Fabricate a new strip panel as specified in WP 0053 00.
3. Position new strip panel on case, and sew using size 3 thread, 5 to 8 stitches per inch and a HD sewing machine.

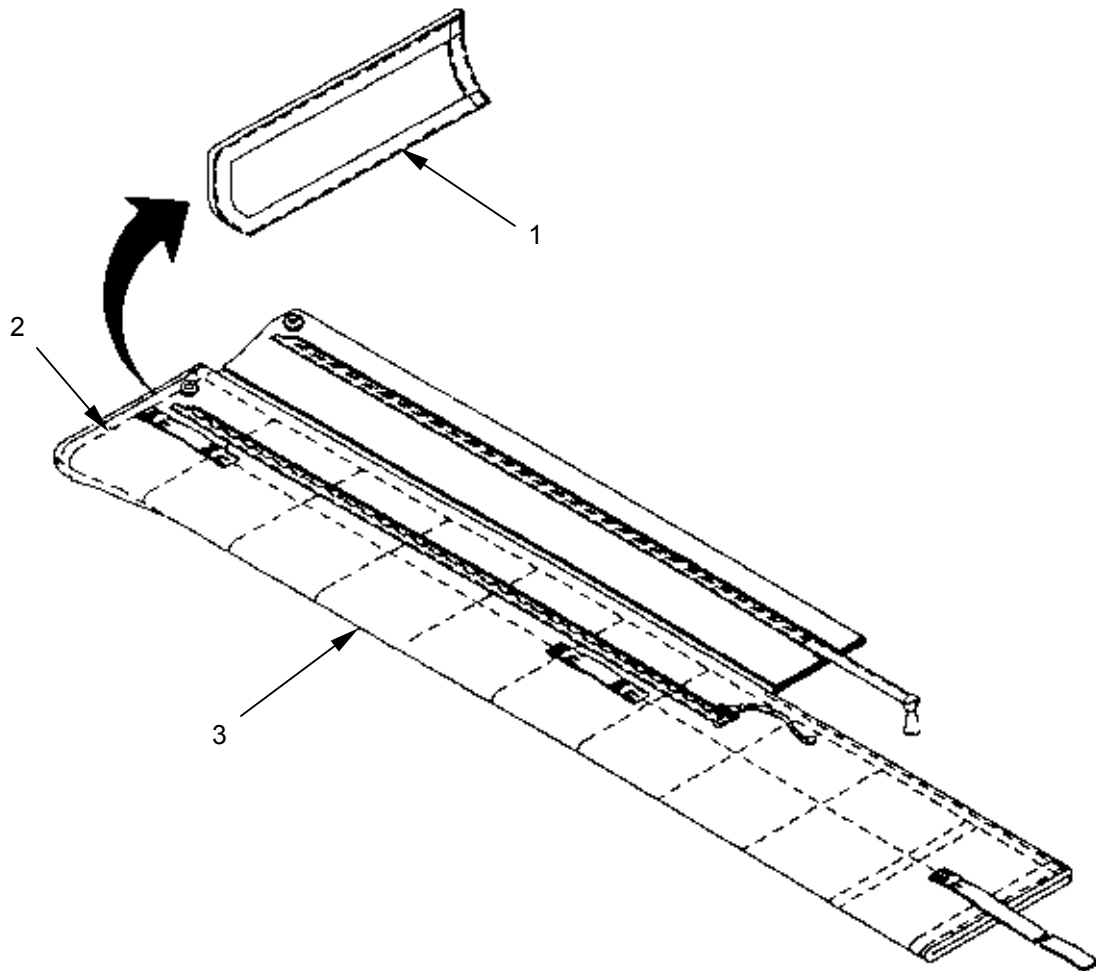

Replace the slide fastener thong, flap thong, tiedown tapes, and corner reinforcement as follows:

1. Slide fastener thong. Replace a damaged or missing slide fastener thong **(1)** with a 20-inch length of $\frac{3}{4}$ -inch Type I cotton tape. Fold tape lengthwise, aligning edges and sew $\frac{1}{8}$ -inch from the edge, using size FF thread, 6 to 9 stitches per inch and a MD sewing machine. Tie ends of tape together with an overhand knot, and install tape on slide fastener.
2. Flap thong. Replace a damaged or missing flap thong **(2)** with a 6-inch length of $\frac{3}{4}$ -inch Type I cotton tape. Fold tape lengthwise, aligning edges, and sew $\frac{1}{8}$ -inch from the edge using size FF thread, 6 to 9 stitches per inch and a MD sewing machine. Stitch thong to case using same method.
3. Tiedown tape. Replace a damaged or missing tiedown tape **(3)** with a length of 1-inch Type I cotton tape. Use a 60-inch length on the bottom tiedown loop and a 54-inch length on the top tiedown loop. Sear ends of tape as described in WP 0013 00. Pass one end of tape under tiedown loop, pull tape halfway halfway through, and tie tape to loop with a square knot.
4. Corner reinforcement. Replace a damaged corner reinforcement **(4)** with a 5 $\frac{1}{2}$ -inch length of 1 $\frac{1}{2}$ -inch Type 1 cotton tape as follows:
 - a. Cut sufficient stitching to expose damaged corner reinforcement.
 - b. Mark and fold tape as shown.
 - c. Position replacement over damaged reinforcement. Sewing $\frac{1}{8}$ of an inch from the edge, stitch replacement to case as shown using size 3 thread, 5 to 8 stitches per inch and a HD sewing machine.
 - d. Restitch loosened stitching. Backstitch at least $\frac{1}{2}$ -inch.

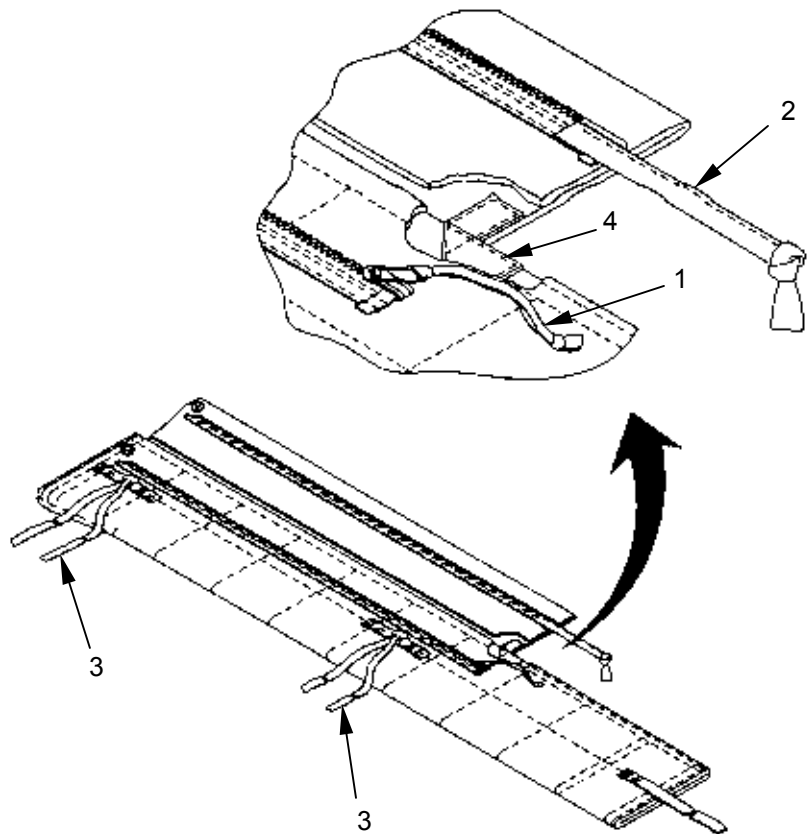

Replace the leather reinforcements follows:

1. Cut an 8-inch square of $\frac{6}{64}$ -inch thick leather **(1)**.
2. Cut stitching along side and bottom of weapons case, and remove damaged reinforcement from case.
3. Position new leather square **(1)** on one side of case with rough side of leather as shown.
4. Sew along one side of reinforcement, $\frac{1}{8}$ -inch from edge **(2)** using size 5 thread, 4 to 6 stitches per inch and a HD sewing machine.
5. Fold case, aligning sides as in original construction. Fold leather reinforcement and sew to other side of case, $4\frac{3}{4}$ -inches from bottom of case **(3)** using size 5 thread, 4 to 6 stitches per inch and a HD sewing machine.
6. Restitch side and bottom of case according to original construction. Backstitch at least $\frac{1}{2}$ -inch.

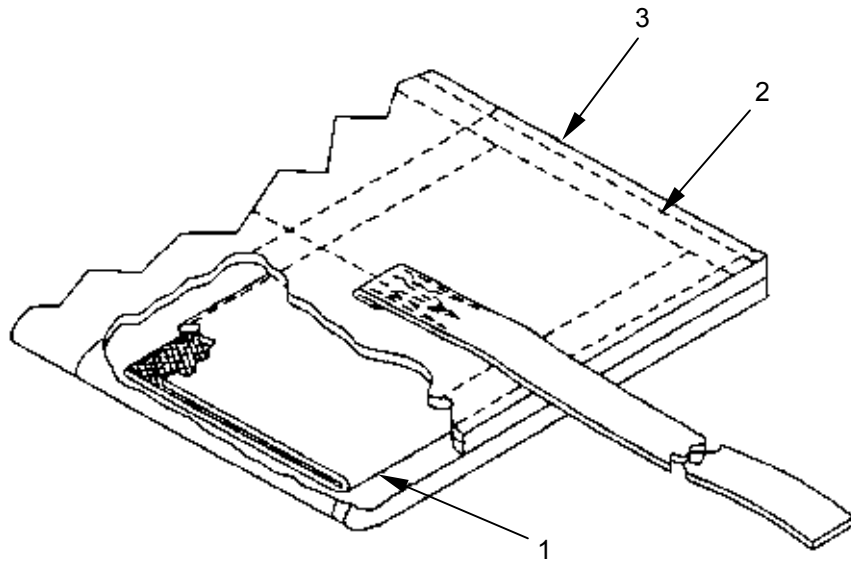

Replacing Webbing.

1. The webbing items listed in 2 through 5 below may be replaced. To replace damaged webbing, cut stitching along side and end of weapons case and along one side of the leather reinforcement. After installing new webbing, restitch leather reinforcement, side and end of case using size 5 thread, 4 to 6 stitches per inch and a HD sewing machine.
2. Tiedown loop.
 - a. Replace a damaged tiedown loop (1) with a 6-inch length of 1-inch Type III cotton webbing.
 - b. Cut stitching, and remove damaged loop.
 - c. Turn under ends of replacement webbing $\frac{1}{2}$ -inch and position replacement on weapons case (2).
 - d. Sew each end of replacement to weapons case with a 3-point WW stitch formation (3) using size 3 thread, 5 to 8 stitches per inch and a HD sewing machine.

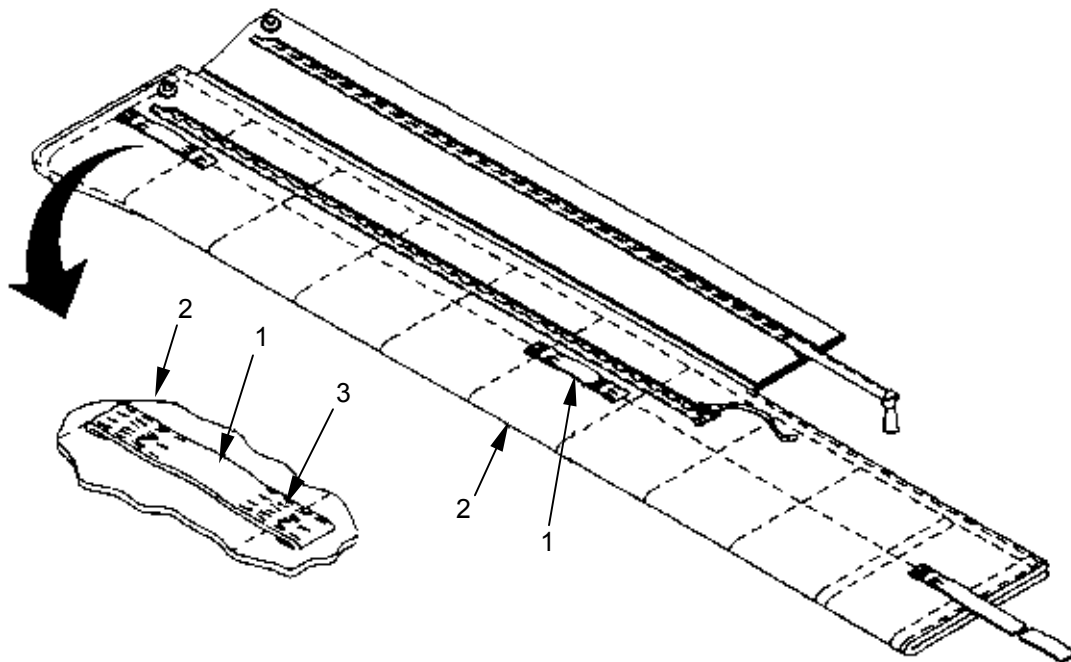

-
3. Loop chap.
 - a. Replace a damaged upper **(1)** or lower **(2)** loop chap with a 7-inch length of 1-inch Type III cotton webbing.
 - b. Cut stitching **(3)** and remove damaged chap and loops. When removing upper loop chap be careful not to cut stitching that secures triangular loop chap **(4)** to case.
 - c. Install loops on replacement webbing, and sew webbing to case with a 3-point WW stitch formation using size 5 thread, 4 to 6 stitches per inch and a HD sewing machine.
 4. Triangular loop chaps. Replace a double-loop **(5)** or single-loop chap **(6)** as follows:
 - a. Double-loop chap.
 - (1) Cut stitching, and remove upper loop chap **(1)** and double-loop chap **(5)** from weapons case. Remove quick-release snap link **(7)** from double-loop chap **(5)** and remove chap webbing from triangular loop.
 - (2) Cut a 27 ½-inch length of Type VIII cotton-nylon webbing, and pass webbing through quick-release snap link **(7)** and triangular loop as shown.
 - (3) Position replacement loop on case, and sew a 3-point WW stitch formation using size 5 thread, 4 to 6 stitches per inch and a HD sewing machine.
 - (4) Stitch upper loop chap **(1)** in place as in a) iii, above.
 - b. Single-loop chap.
 - (1) Cut stitching, and remove damaged single loop chap **(6)** from weapons case. Remove chap webbing from triangular loop **(8)**.
 - (2) Cut an 8-inch length of Type VIII cotton nylon webbing. Thread webbing through triangular loop, position webbing on case, and sew a 3-point WW stitch formation **(9)** using size 5 thread, 4 to 6 stitches per inch and a HD sewing machine.

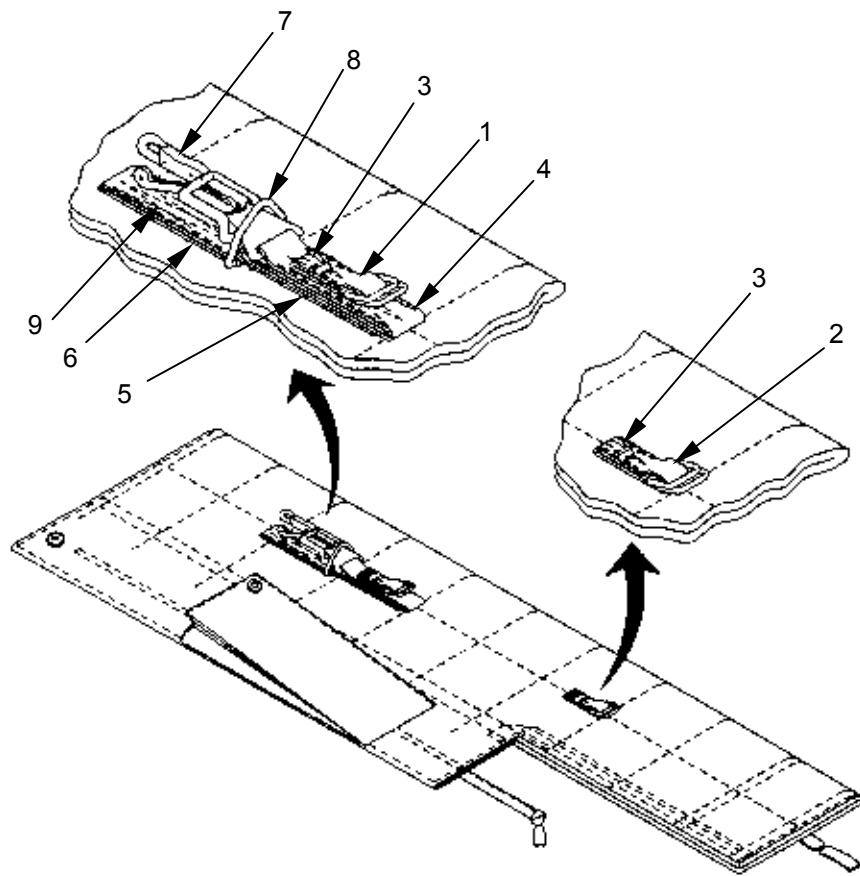

- (5) Adjusting strap.
- c. Replace a damaged adjusting strap **(1)** with a 25 $\frac{1}{2}$ -inch length of 1-inch Type III cotton webbing as follows:
- (1) Cut stitching, and remove damaged strap.
 - (2) Install an end clip **(3)** at one end of replacement webbing. If end clip is not available dip end of webbing in wax to a depth of 2-inches. Fold other end of webbing under, $\frac{1}{2}$ -inch.
 - (3) Cut stitching along side and bottom of case as needed.
 - (4) Position webbing on weapons case as in original construction, and sew a 2-inch 3-point WW stitch formation **(2)**. Overstitch end of webbing $\frac{1}{8}$ -of an inch. Use size 5 thread, 4 to 6 stitches per inch and a HD sewing machine.

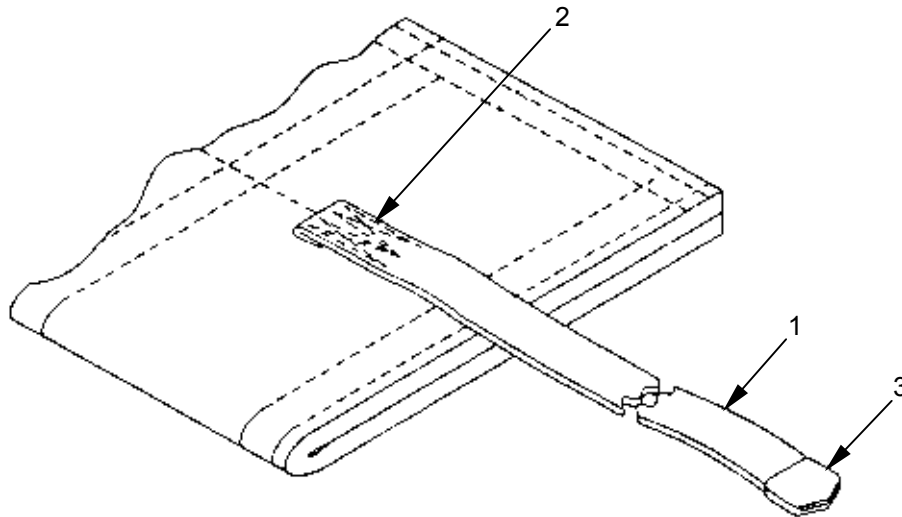

(6) Replacing Hardware.

- d. Snap fastener (1). Replace a damaged snap fastener with a serviceable like item from stock. Install fastener in accordance with procedures described in WP 0015 00.
- e. Other hardware items. Replace other damaged items of hardware on the weapons case with serviceable like items from stock. Do not attempt to straighten bent hardware or otherwise repair cracked or broken hardware. When it is necessary to cut any stitching to remove damaged hardware from webbing, replace hardware and webbing following procedures in the appropriate section of 5., above. Do not restitch the webbing.

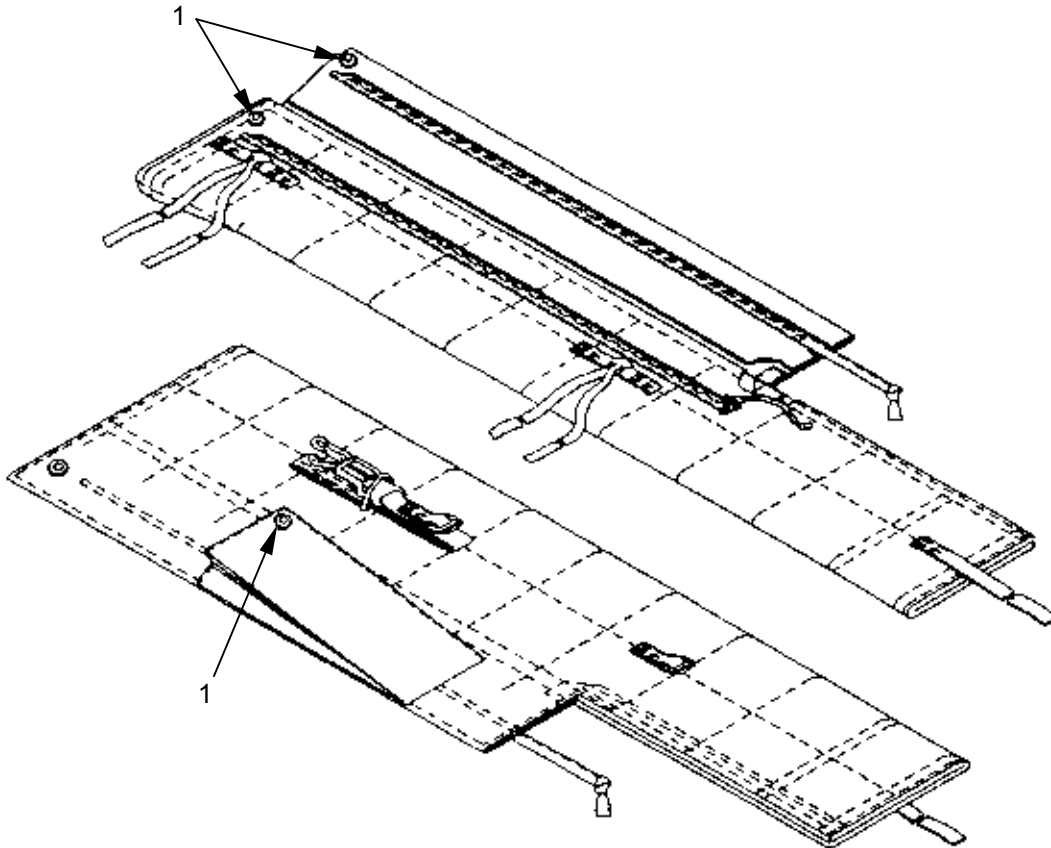

END OF WORK PACKAGE

ANCILLARY EQUIPMENT FOR PERSONNEL PARACHUTE SYSTEM

**CASE, PARACHUTIST'S INDIVIDUAL WEAPON M-1950 (NYLON)
INSPECT, REPAIR, REPLACE**

INITIAL SETUP:

Tools

Knife (WP 0034 00, Table 2, Item 6)
Shears (WP 0034 00, Table 2, Item 20)
Sewing Machine, Darning (WP 0034 00, Table 2, Item 15)
Sewing Machine, HD (WP 0034 00, Table 2, Item 16)
Sewing Machine, MD (WP 0034 00, Table 2, Item 18)

Personnel Required

92R(10) Parachute Rigger

Materials/Parts

Beeswax, technical (WP 0052 00, Table 1, Item 1)
Cloth, duck, nylon, Type II (WP 0052 00, Table 1, Item 10)
Felt, 1/4-inch (WP 0052 00, Table 1, Item 17)
Ink, marking, parachute, strata-blue (WP 0052 00, Table 1, Item 21)
Webbing, Reinforcement (WP 0052 00, Table 1, Item 68)
Lubricant, Stick form (WP 0052 00, Table 1, Item 24)
Thread, size 3 (WP 0052 00, Table 1, Item 47)
Thread, nylon, size 5 (WP 0052 00, Table 1, Item 48)
Thread, nylon, size FF (WP 0052 00, Table 1, Item 51)
Webbing, nylon, type VIII (WP 0052 00, Table 1, Item 56)
Tape, Fastener, Hook, 1 1/2-inch (WP 0052 00, Table 1, Item 32)
Tape, Fastener, Pile, 1 1/2-inch (WP 0052 00, Table 1, Item 35)
Webbing, nylon, type III, 1-inch (WP 0052 00, Table 1, Item 58)
Webbing, nylon, type VII (WP 0052 00, Table 1, Item 65)

Equipment Condition

Parachutist's Weapon's and Individual Equipment Pack and Harness Assembly should be clean and dry. Place assembly on worktable.

INSPECT

Perform a before and after technical/rigger type inspection of the nylon M-1950 weapons case as outlined in WP 0008 00.

NOTE

The nylon M-1950 replaces the cotton M-1950 in its entirety.

REPAIR

The nylon duck (1) and felt (2) fabric of the case may be restitched, darned, patched and plugged.

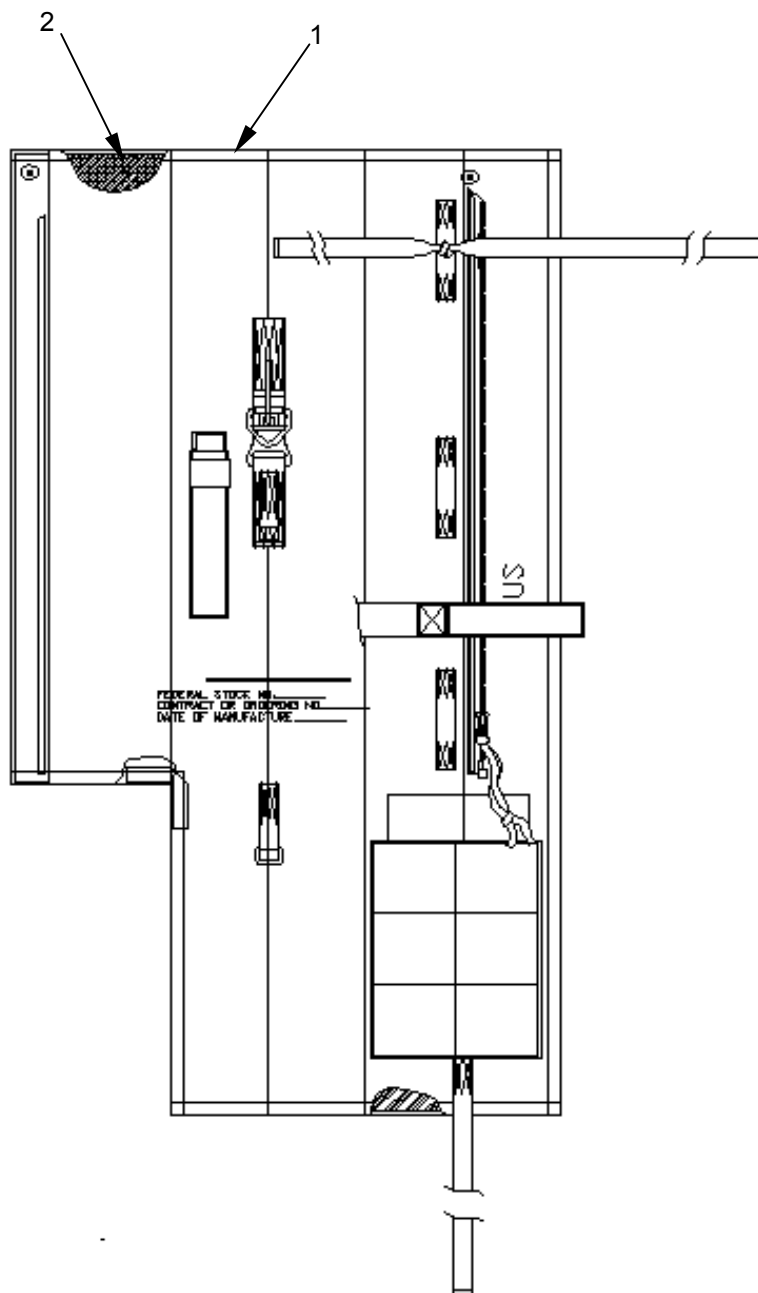

1. Restitching. Restitch the case fabric **(1)** directly over old stitching using size 5 thread, 5 to 8 stitches per inch, and a HD sewing machine. Lock stitching at least $\frac{1}{2}$ -inch.
2. Darning. Darn a hole or tear in the case fabric that does not exceed 1-inch in length or diameter using size E thread and a ZZ darning machine. There is no limit to darns that may be applied, provided they do not weaken or reduce the original strength of the fabric more than 10%. If damage is in the lined portion of the case and only the nylon duck is damaged, darn through duck and felt. If felt is also damaged, remove damaged area before darning duck fabric. Then plug felt as in 3. c) below.
3. Patching. There is no limit to the number of times the case may be patched. Patch a hole or tear that exceeds 1-inch in length or diameter following procedures in a) or b) below. Use nylon duck cloth according to original construction for patching outside, and $\frac{1}{4}$ -inch thick felt for plugging inside lining.
Use a MD sewing machine, size FF thread, and 6 to 9 stitches per inch.
 - a. To patch a lined portion of the case **(1)** when the felt **(2)** is not damaged, cut a nylon or cotton duck patch **(3)** 2-inches beyond circumference of damaged portion. Turn under edges of patch $\frac{1}{2}$ -inch and center patch **(3)** over damaged area. Sew patch to case with a double row of stitching **(4)** as shown.

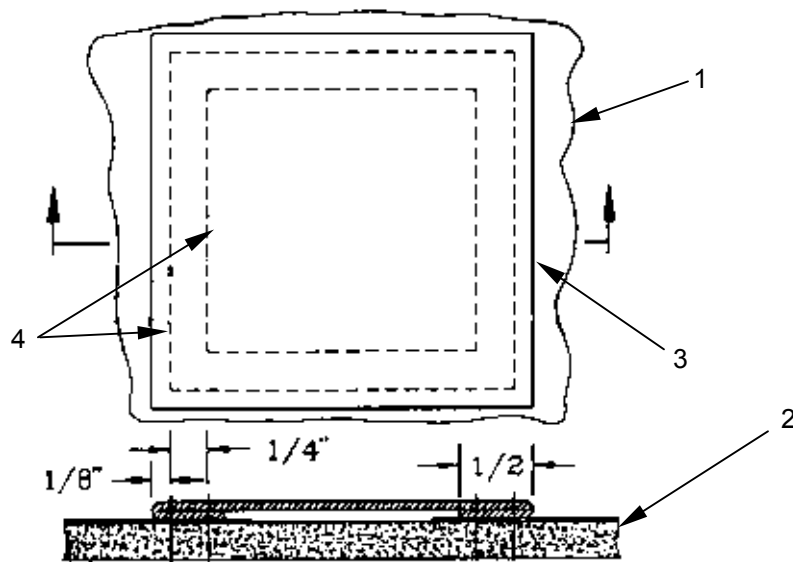

- b. To patch a lined portion of the case (1) when the felt (2) is damaged, remove the damaged felt as described in c) below. Cut a piece of felt the same size as the piece removed, and position felt plug and nylon duck patch (3) (with edges turned under 1/2-inch) over damaged area. Sew a single box X stitch (4) formation as shown.

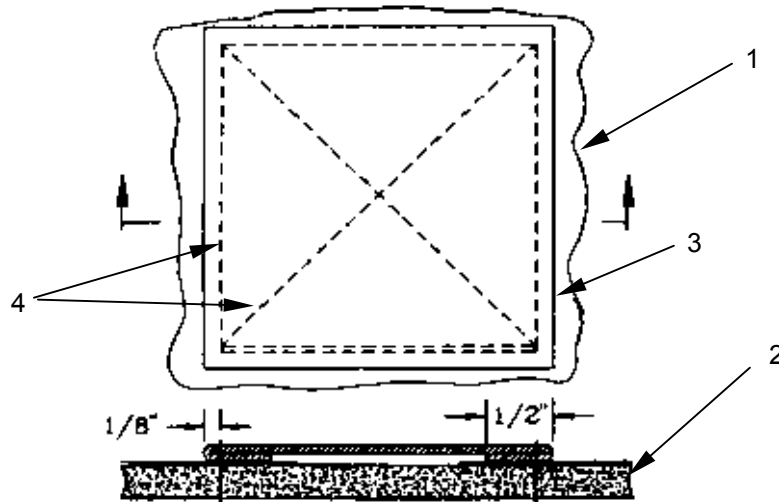

- c. To plug the felt (1) lining, mark a rectangle around the damaged area. Remove the damaged felt while being careful not to damage the nylon duck material (2). Cut a piece of felt (1) the size of the piece removed. Position felt plug into area cleared and sew as shown. Use size 3 thread, 5 to 8 stitches (3) per inch and a HD sewing machine.

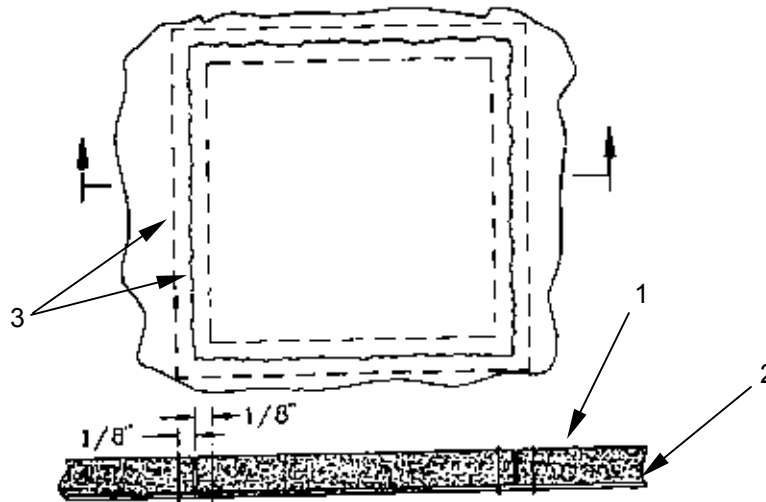

- d. Repairing Tape, Webbing and Inner Reinforcement Webbing. Restitching is the only repair authorized for the tape, webbing, and leather items on the weapons case. Restitch loose or broken stitching on the corner reinforcement, tiedown loops, quick-adjustable buckle loop and shock absorber loop using size 3 thread, 5 to 8 stitches per inch and a HD sewing machine. Restitch flap thong, and slide fastener thong, using size FF thread, 6 to 9 stitches per inch and a MD sewing machine. Restitch the inner reinforcement webbing using size 3 thread, 5 to 8 stitches per inch and a HD sewing machine. Backstitch at least $\frac{1}{2}$ -inch.
- e. Repairing and Lubricating Slide Fastener. Restitch loose or broken stitching on slide fastener tape using size FF thread, 6 to 9 stitches per inch and a MD sewing machine. Apply a small amount of "zipper ease" lubricant to slide fastener when it becomes difficult to operate.

REPLACE

Replace the lowering line pocket (1) as follows:

1. Cut stitching (2) and remove damaged pocket.
2. Fabricate a new pocket as specified in WP 0053 00.

CAUTION

Avoid sewing through slide fastener when attaching new lowering line pocket. Damage to the slide fastener will result.

3. Position new pocket on weapons case (3), turn edges under $\frac{1}{2}$ -inch, and sew pocket to case using size 3 thread, 5 to 8 stitches per inch and a HD sewing machine.

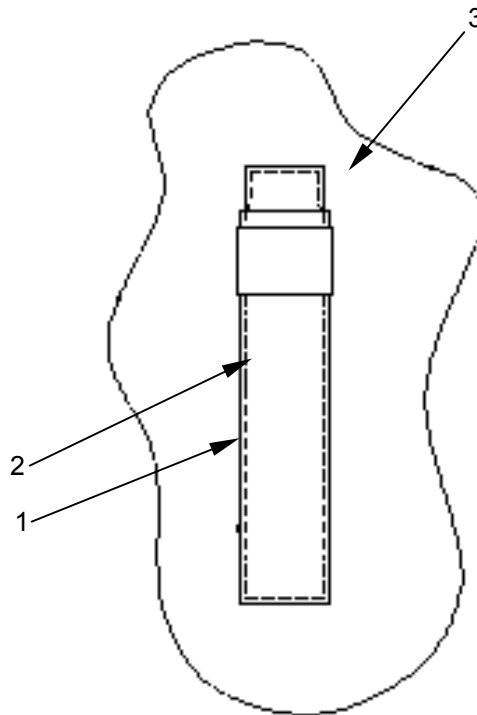

Replace the slide fastener thong, tiedown tapes, and corner reinforcement as follows:

1. Slide fastener thong. Replace a damaged or missing slide fastener thong **(1)** with a 14-inch length of $\frac{3}{8}$ -inch Type III nylon tape. Fold tape lengthwise, aligning edges and sew $\frac{1}{8}$ -inch from the edge, using size FF thread, 6 to 9 stitches per inch and a MD sewing machine. Tie ends of tape together with an overhand knot, and install tape on slide fastener.
2. Lower strap. Replace the lower strap **(2)** as follows:
 - a. Cut stitching **(3)** and remove damaged lower leg strap.
 - b. Fabricate a new lower leg strap as specified in WP 0053 00.
 - c. Position new lower leg strap in original location using size 3 thread, 5 to 8 stitches per inch and a HD sewing machine.
3. Upper tiedown tape. Replace a damaged or missing upper tiedown tape **(4)** with a length of 1-inch Type I cotton tape. Use a 54-inch length on the top tiedown loop. Sear ends of tape as described in WP 0013 00. Pass one end of tape under tiedown loop, pull tape halfway halfway through, and tie tape to loop with a square knot.
4. Corner reinforcement. Replace a damaged corner reinforcement **(5)** with a $6\frac{3}{4}$ -inch length of 1-inch wide Type III nylon webbing as follows:
 - a. Cut sufficient stitching to expose damaged corner reinforcement.
 - b. Mark and fold webbing as shown.
 - c. Position replacement over damaged reinforcement. Sewing $\frac{1}{8}$ of an inch from the edge, stitch replacement to case as shown using size 3 thread, 5 to 8 stitches per inch and a HD sewing machine.
 - d. Restitch loosened stitching. Backstitch at least $\frac{1}{2}$ -inch.

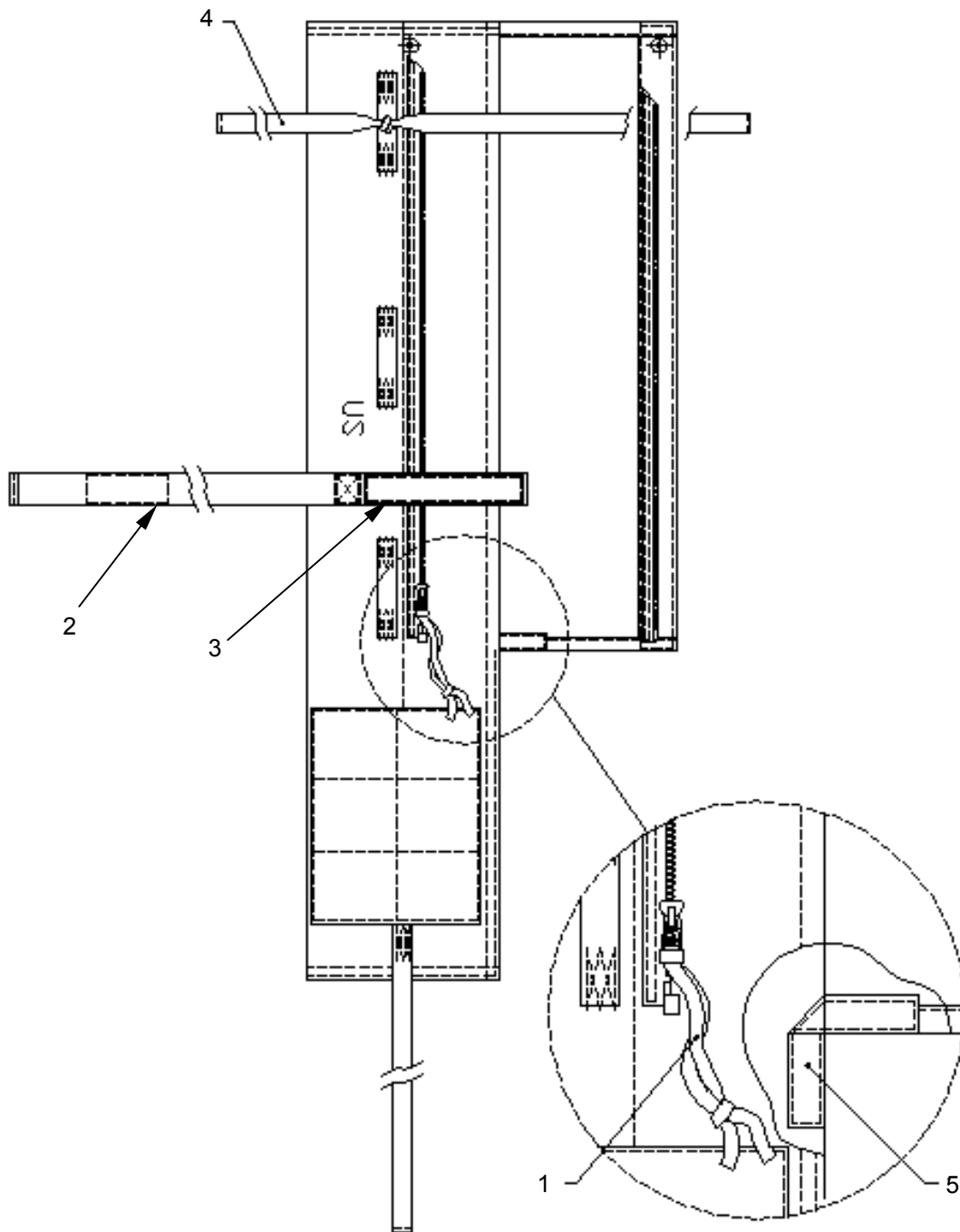

Replace the inner webbing reinforcements as follows:

1. Cut two, 38 $\frac{1}{4}$ -inch lengths of webbing and sew together as in WP 0053 00 **(1)**.
2. Cut stitching along side and bottom of weapons case, and remove damaged webbing reinforcement from case.
3. Position new webbing in original location and sew as in WP 0053 00.
4. Fold case, aligning sides as in original construction. Restitch side and bottom of case **(2)** using size 5 thread, 4 to 6 stitches per inch and a HD sewing machine.
5. Backstitch at least $\frac{1}{2}$ -inch.

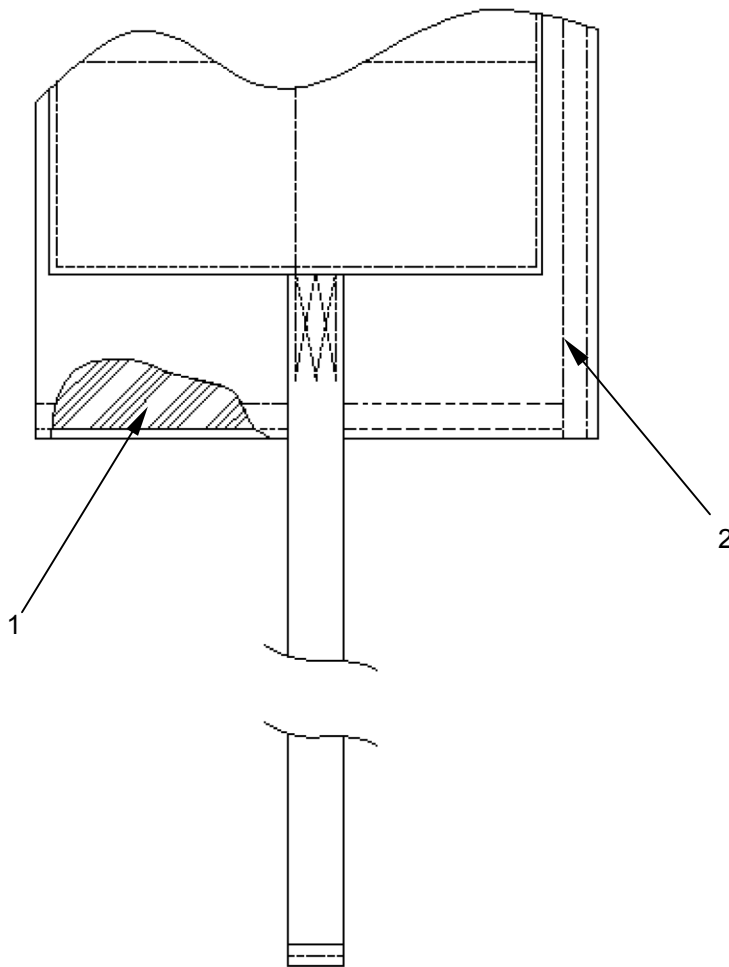

Replacing Webbing.

1. The webbing items listed in 2 through 5 below may be replaced. To replace damaged webbing, cut stitching along side and end of weapons case and along one side of the leather reinforcement. After installing new webbing, restitch leather reinforcement, side and end of case using size 5 thread, 4 to 6 stitches per inch and a HD sewing machine.
2. Tiedown loop.
 - a. Replace a damaged tiedown loop **(1)** with a 6-inch length of 1-inch Type III nylon webbing.
 - b. Cut stitching, and remove damaged loop.
 - c. Sear ends of type III nylon webbing and position replacement on weapons case **(2)**.
 - d. Sew each end of replacement to weapons case with a 3-point WW stitch formation **(3)** using size 3 thread, 5 to 8 stitches per inch and a HD sewing machine. Carry stitching over end of webbing one stitch minimum, 2 stitches maximum.

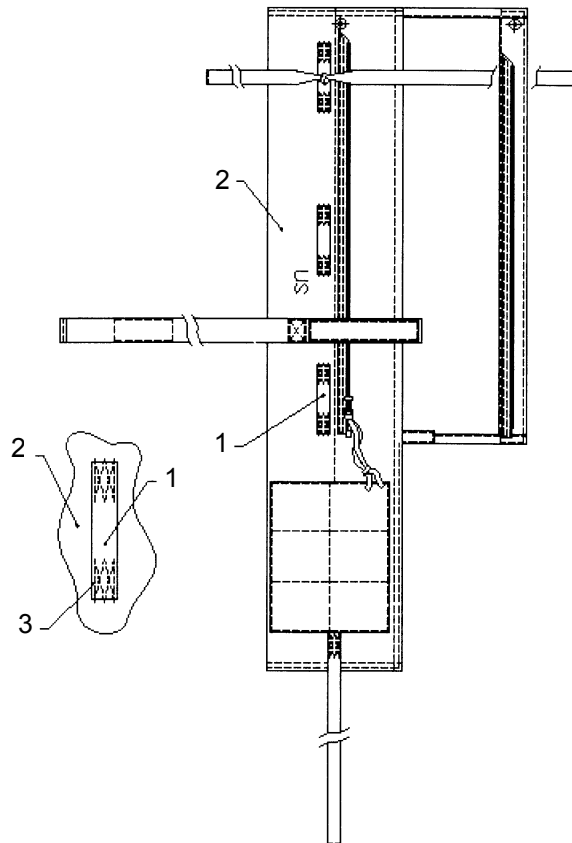

-
3. Loop chap.
 - a. Replace a damaged upper **(1)** or lower **(2)** loop chap with a 7-inch length of 1-inch Type III nylon webbing.
 - b. Cut stitching **(3)** and remove damaged chap and loops. When removing upper loop chap be careful not to cut stitching that secures snap link loop chap **(4)** to case.
 - c. Install loops on replacement webbing, and sew webbing to case with a 3-point WW stitch formation using size 5 thread, 4 to 6 stitches per inch and a HD sewing machine.
 4. Triangular loop chaps. Replace a double-loop **(5)** or single-loop chap **(6)** as follows:
 - a. Double-loop chap.
 - (1) Cut stitching, and remove upper loop chap **(1)** and double-loop chap **(5)** from weapons case. Remove quick-release snap link **(7)** and snap link loop **(4)**.
 - (2) Cut a 32-inch length of Type VII nylon webbing, and pass webbing through quick-release snap link **(7)** and snap link loop as shown.
 - (3) Position replacement double chap loop on case along with the original single loop chap **(6)**, and sew a 4-point WW stitch formation using size 5 thread, 4 to 6 stitches per inch and a HD sewing machine.
 - (4) Stitch upper loop chap **(1)** in place as in 3 c), above.
 - b. Single-loop chap.
 - (1) Cut stitching and remove upper loop chap, cut stitching on lower double chap and remove damaged single loop chap **(6)** from weapons case.
 - (2) Cut a 13 1/2-inch length of Type VIII nylon webbing. Thread webbing through U-ring loop, position webbing on case, and sew a 4-point WW stitch formation **(8)** using size 5 thread, 4 to 6 stitches per inch and a HD sewing machine.

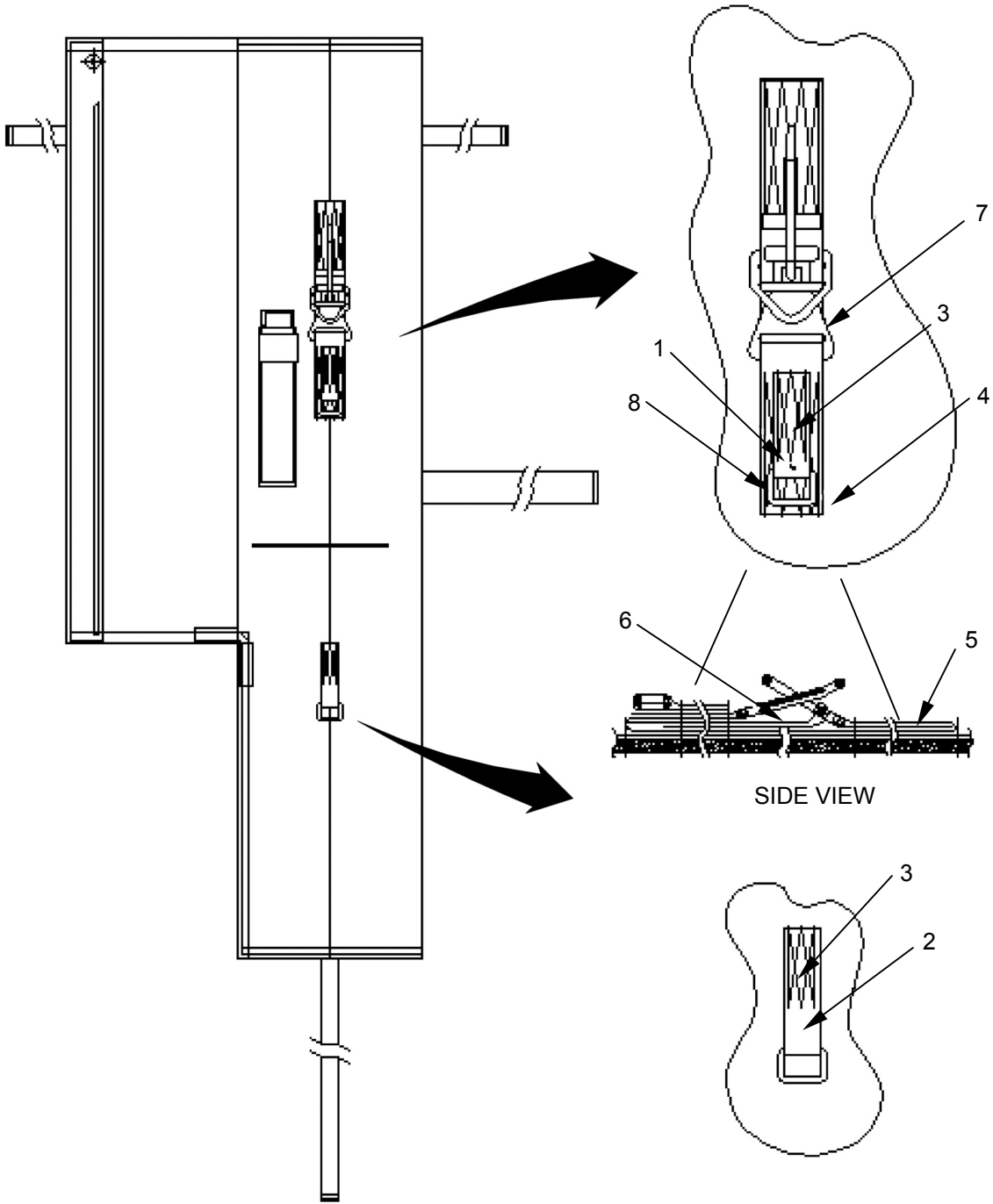

5. Adjusting strap. Replace a damaged adjusting strap **(1)** with a 25 1/2-inch length of 1-inch Type III nylon webbing as follows:
 - a. Cut stitching, and remove damaged strap.
 - b. Install an end clip **(3)** at one end of replacement webbing. If end clip is not available sear webbing end.
 - c. Cut stitching along side and bottom of case as needed to replace strap.
 - d. Position webbing on weapons case as in original construction, and sew a 2-inch 3-point WW stitch formation **(2)**. Overstitch end of webbing 1/8 of an inch. Use size 5 thread, 4 to 6 stitches per inch and a HD sewing machine.

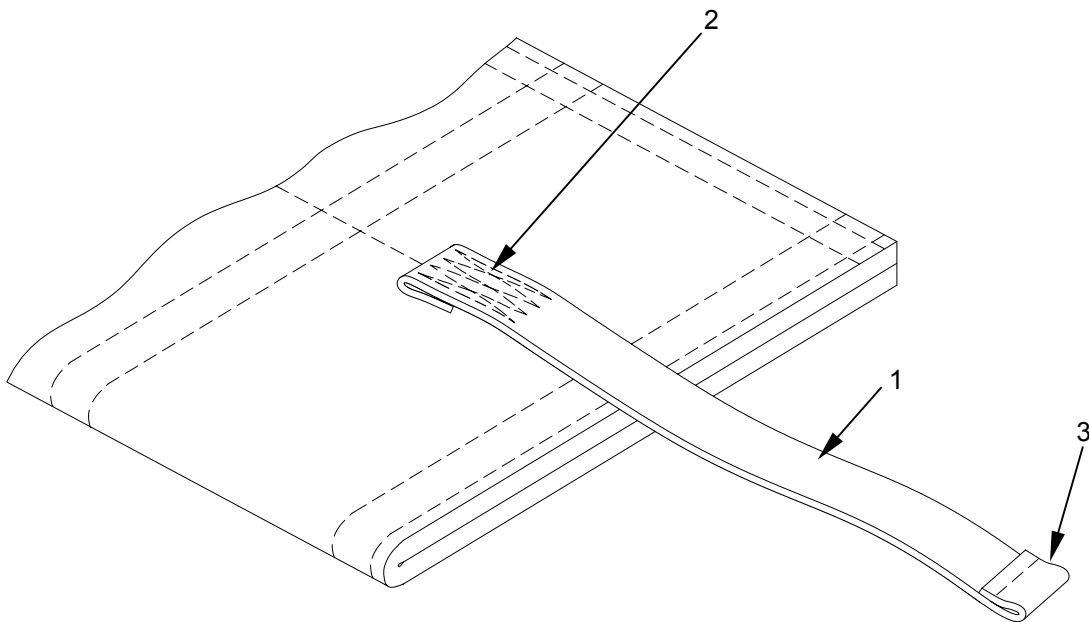

6. Replacing Hardware.

- a. Snap fastener (1). Replace a damaged snap fastener with a serviceable like item from stock. Install fastener in accordance with procedures described in WP 0015 00.
- b. Other hardware items. Replace other damaged items of hardware on the weapons case with serviceable like items from stock. Do not attempt to straighten bent hardware or otherwise repair cracked or broken hardware. When it is necessary to cut any stitching to remove damaged hardware from webbing, replace hardware and webbing following procedures in the appropriate section of 5., above. Do not restitch the webbing.

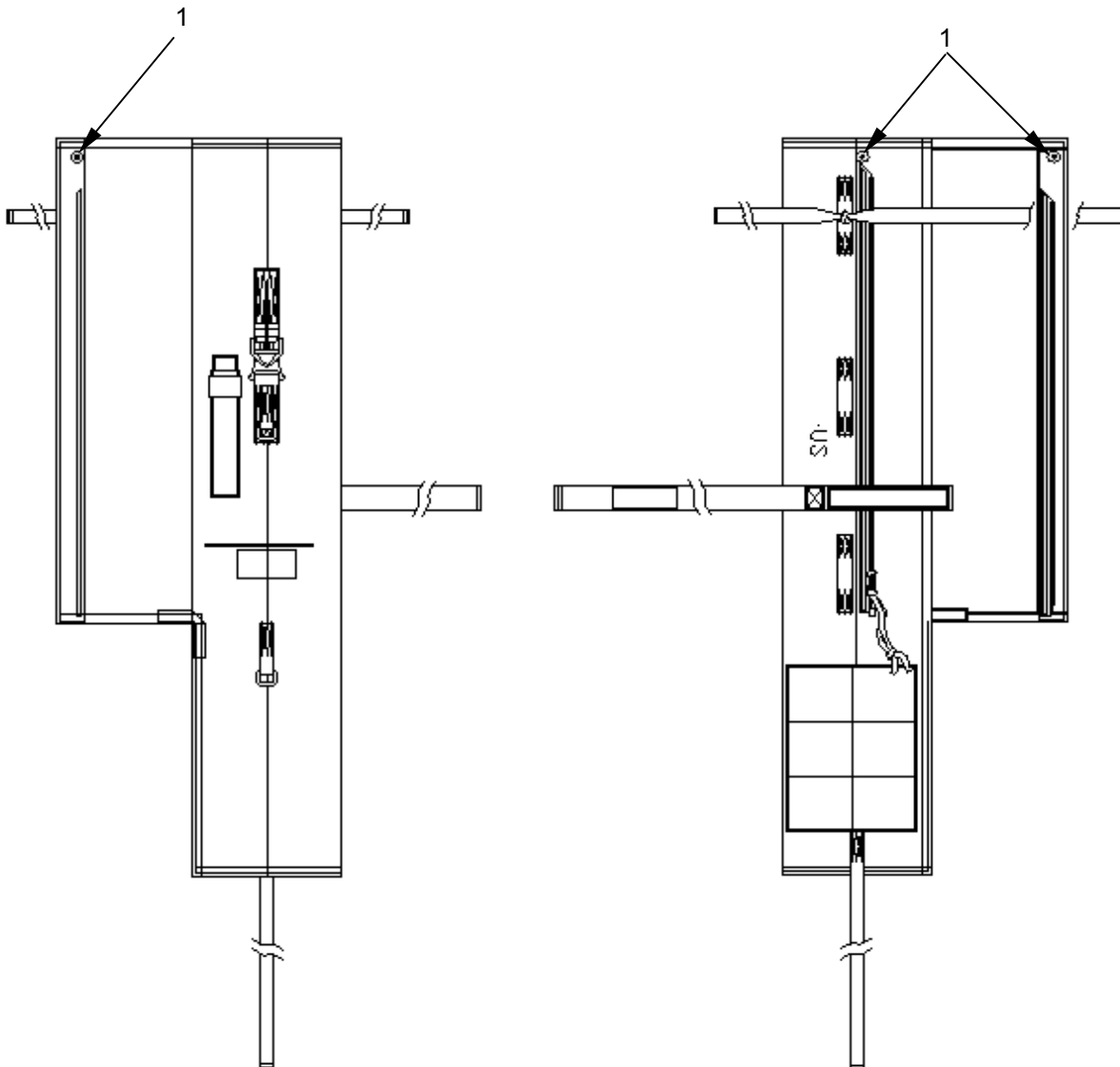

END OF WORK PACKAGE

UNIT MAINTENANCE

ANCILLARY EQUIPMENT FOR PERSONNEL PARACHUTE SYSTEM

PARACHUTIST'S WEAPONS AND INDIVIDUAL EQUIPMENT PACK AND HARNESS ASSEMBLY
INSPECT, REPAIR, REPLACE**INITIAL SETUP:****Tools**

Knife (WP 0034 00, Table 2, Item 6)
 Needle, Tacking (WP 0034 00, Table 2, Item 9)
 Pot, Melting (WP 0034 00, Table 2, Item 10)
 Sewing Machine, Darning (WP 0034 00, Table 2, Item 15)
 Sewing Machine, HD (WP 0034 00, Table 2, Item 16)
 Sewing Machine, LD (WP 0034 00, Table 2, Item 17)
 Sewing Machine, MD (WP 0034 00, Table 2, Item 18)
 Shears (WP 0034 00, Table 2, Item 20)

Personnel Required

92R(10) Parachute Rigger

Materials/Parts

Beeswax, 1 lb cake (WP 0052 00, Table 1, Item 1)
 Cloth, duck, cotton (WP 0052 00, Table 1, Item 7)
 Felt, 1/4-inch (WP 0052 00, Table 1, Item 17)
 Tape, cotton (WP 0052 00, Table 1, Item 43)
 Thread, nylon, size 3 (WP 0052 00, Table 1, Item 47)
 Thread, nylon, size E (WP 0052 00, Table 1, Item 50)
 Thread, nylon, size FF (WP 0052 00, Table 1, Item 51)
 Webbing, nylon, Type IV (WP 0052 00, Table 1, Item 60)
 Webbing, nylon, Type VIII (WP 0052 00, Table 1, Item 61)
 Wax, Paraffin, Type I, Technical, 1 lb cake (WP 0052 00, Table 1, Item 52)

Equipment Condition

Parachutist's Pack and Harness Assembly should be clean and dry. Place Pack and Harness Assembly on worktable.

INSPECT

Perform a before and after technical/rigger type inspection of the Parachutist's Weapon and Individual Equipment Pack and Harness assembly as outlined in WP 0008 00.

REPAIR

The pack (1) cotton duck (2) and felt (3) fabrics may be restitched, darned, and patched. The felt lining may be restitched and plugged. When making any of these repairs, remove stitching (4) from side and end of pack as necessary to gain access to the damaged area. After repairs have been made, replace any stitching (4) that has been removed, as in original construction or as specified in each procedure. Repair duck (2) and felt (3) fabrics by Restitching darning and patching as described below.

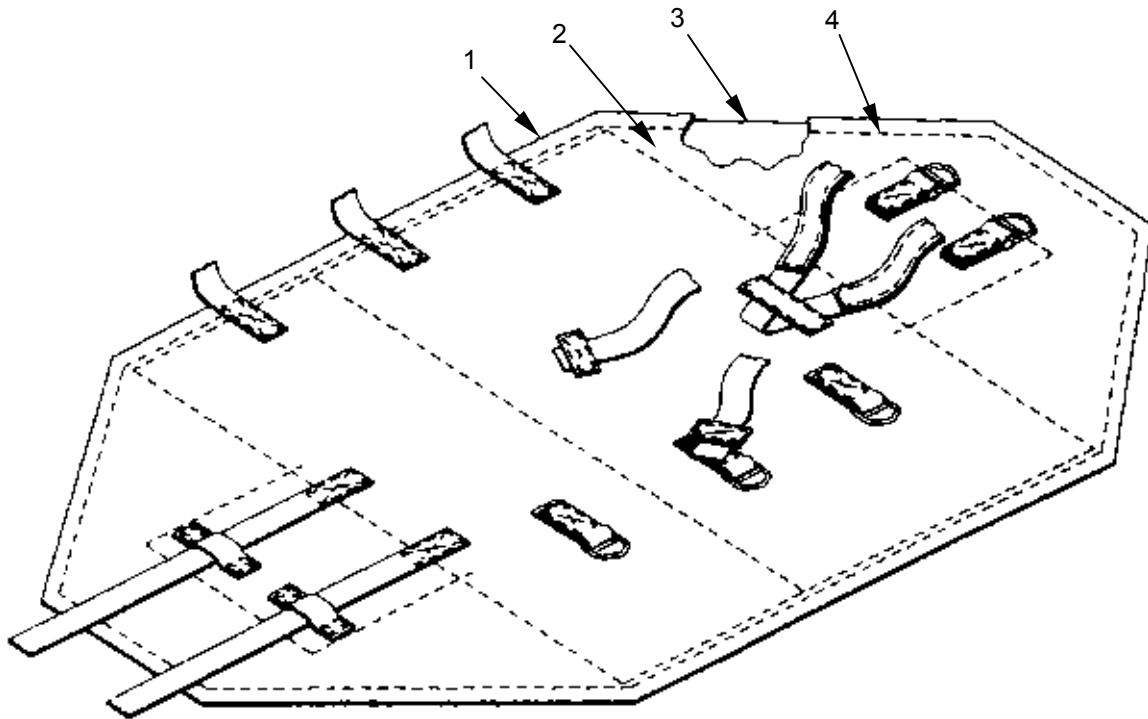

1. Restitching. Restitch the case fabric **(1)** directly over old stitching using size E thread, 7 to 11 stitches per inch, and a MD sewing machine. Lock stitching at least $\frac{1}{2}$ -inch.
2. Darning. Darn a hole or tear in the pack fabric that does not exceed 1-inch in length or diameter using size E thread and a darning machine. There is no limit to darns that may be applied, provided they do not weaken or reduce the original strength of the fabric more than 10%. If damage is in the lined portion of the pack body and only the cotton duck is damaged, darn through duck and felt. If felt is also damaged, remove damaged area before darning duck fabric. Then plug felt as in 3. c) below.
3. Patching. There is no limit to the number of times the pack body may be patched. Patch a hole or tear that exceeds 1-inch in length or diameter following procedures in a) or b) below. Use cotton duck cloth according to original construction for patching outside, and $\frac{1}{4}$ -inch thick felt for plugging inside lining. Use a MD sewing machine, size FF thread, and 6 to 9 stitches per inch.
 - a. To patch a lined portion of the pack **(1)** when the felt **(2)** is not damaged, cut nylon or cotton duck patch **(3)** 2-inches beyond circumference of damaged portion. Turn under edges of patch $\frac{1}{2}$ -inch and center patch **(3)** over damaged area. Sew patch to container body with a double row of stitching **(4)** as shown.

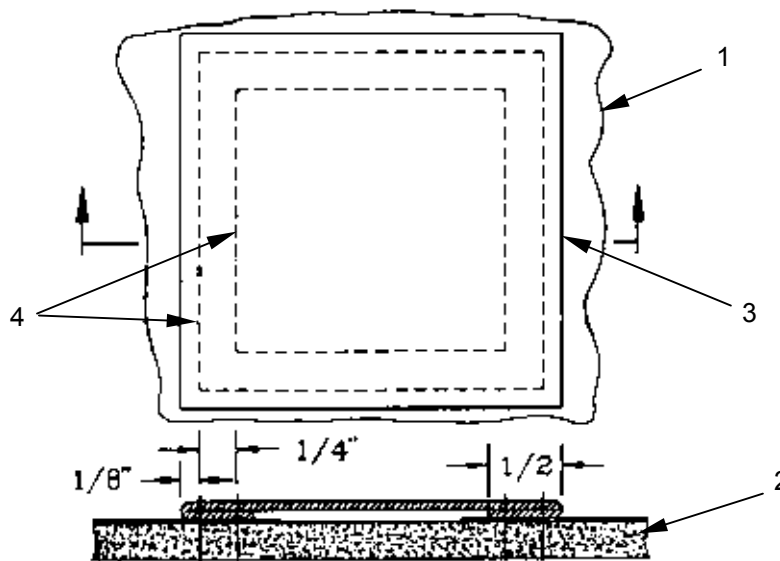

- b. To patch a lined portion of the pack (1) when the felt (2) is damaged, remove the damaged felt as described in c) below. Cut a piece of felt the same size as the piece removed, and position felt plug and cotton duck patch (3) (with edges turned under 1/2-inch) over damaged area. Sew a single box X stitch (4) formation as shown.

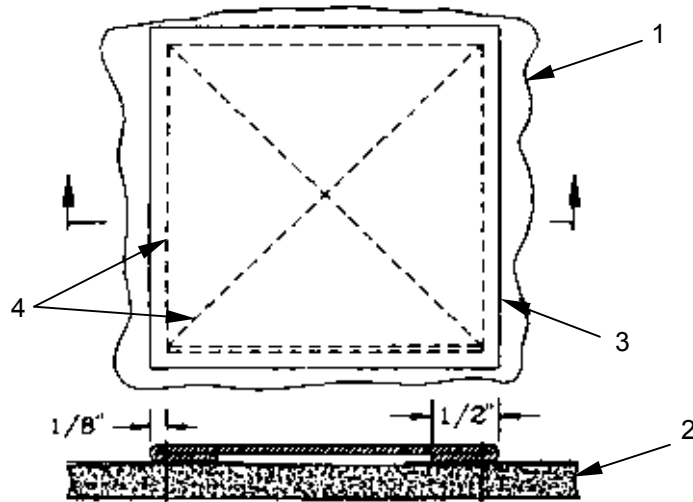

- c. To plug the felt (1) lining of pack (2), mark a rectangle around the damaged area. Remove the damaged felt while being careful not to damage the nylon duck material (3). Cut a piece of felt the size of the piece removed. Position felt plug into area cleared and sew as shown.

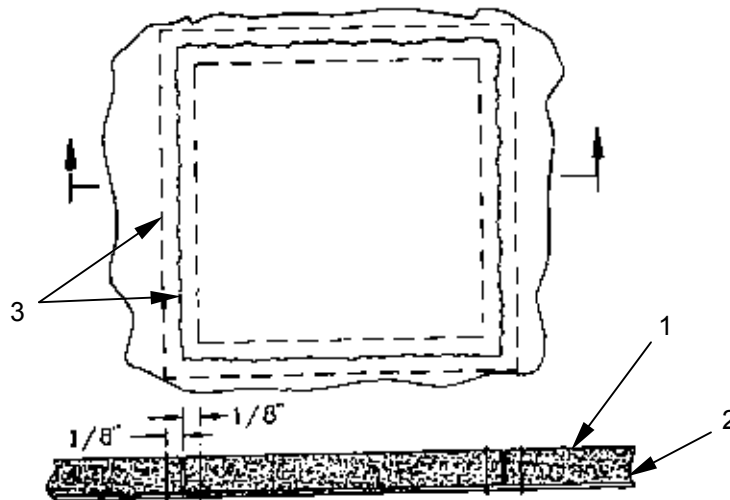

- d. If damage is in an area that cannot be sewn by machine, tack felt (1) plug securely to cotton duck (2) as shown using doubled and waxed size 3 nylon thread. Secure thread ends with suitable knot.

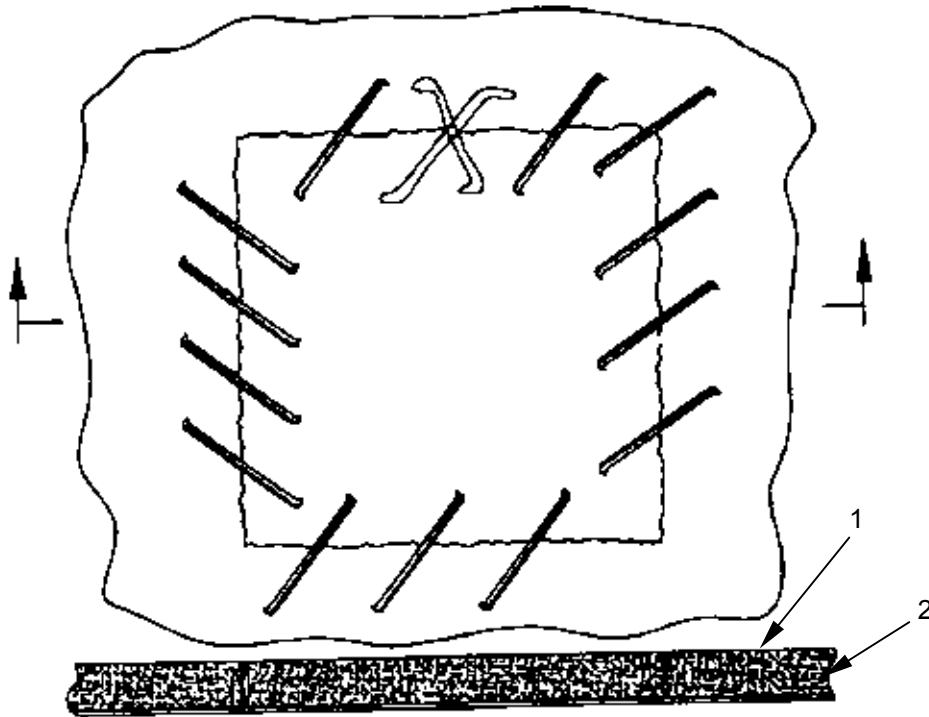

CAUTION

If webbing is inadvertently damaged when stitching is being removed, the webbing must be replaced in accordance with original construction.

4. Repairing Pack Webbing.

- a. General. The webbing on the pack may be restitched, and the upper suspender strap **(1)** may be spliced.
- b. Restitching. Restitch loose or broken stitching using size 3 thread, 5 to 8 stitches per inch and a HD sewing machine.
- c. Splicing upper suspender strap. Splice a frayed, torn, or cut upper suspender strap **(1)** as follows:
 - (1) Cut a piece of Type VIII nylon webbing **(2)** long enough to extend 4-inches beyond each side of damaged area, and sear ends as described in WP 0013 00.
 - (2) Center webbing lengthwise over damaged area, and sew a 3-point WW stitch **(3)** formation at each end of webbing at each end of splice. Use size 3 thread, 5 to 8 stitches per inch and a HD sewing machine. Overstitch reinforcement $\frac{1}{8}$ -inch.

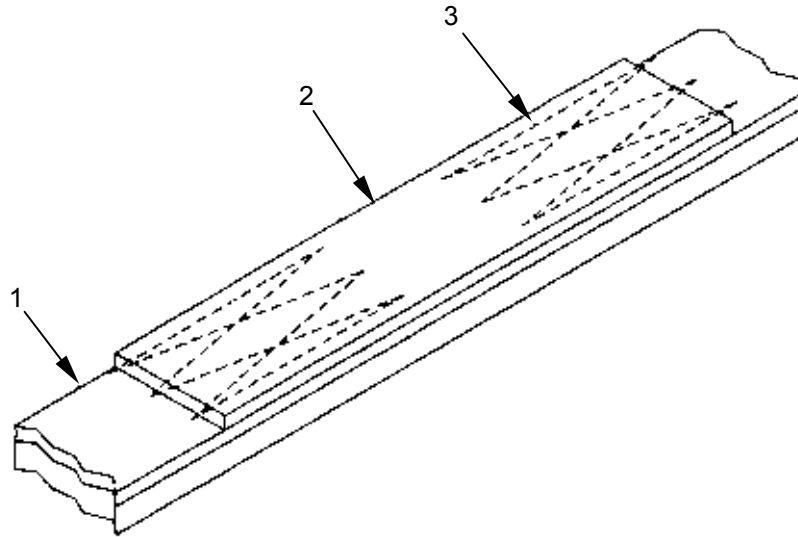

5. Repairing Harness Cotton Duck Fabric.

- a. General. The cotton duck fabric of the harness may be restitched or darned. These are the only repairs authorized. Restitch using size E thread, 7 to 11 stitches per inch and a MD sewing machine. Backstitch at least $\frac{1}{2}$ -inch. Darn holes that do not extend 1-inch in length or diameter using size E thread and a DN machine.

6. Repairing Harness Webbing.

- a. General. The webbing on the harness may be restitched, and the suspension straps **(1)**, body reinforcement strap **(2)**, handle strap **(3)**, end securing straps **(4)**, and side securing straps **(5)** may be spliced as follows:

- (1) Cut a piece of Type VIII nylon webbing long enough to extend 4-inches beyond each side of damaged area, and sear ends.
- (2) Center webbing lengthwise over damaged area, and sew a 3-point WW stitch formation at each end of webbing at each end of splice. Use size 3 thread, 5 to 8 stitches per inch and a HD sewing machine. Overstitch reinforcement $\frac{1}{8}$ -inch.

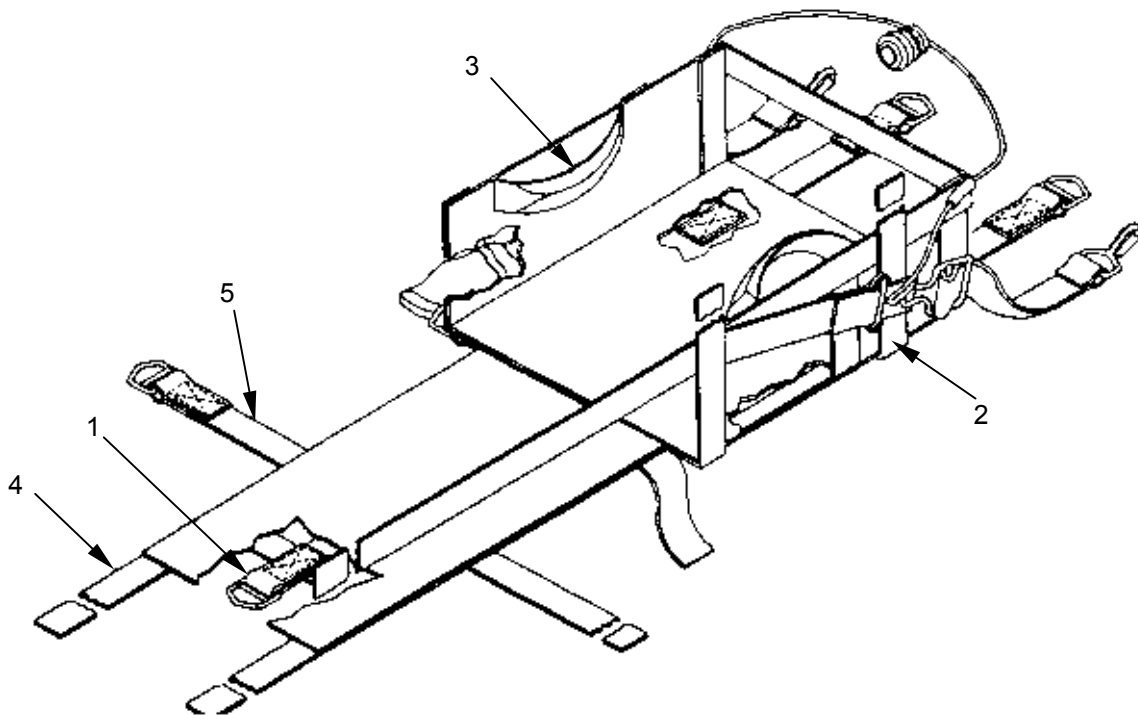

REPLACE

- (3) Replacing Pack Felt End Panel (1).
- (a) Cut stitching (2) and remove damaged end panel (1).
 - (b) Cut a 12-inch by 13-inch piece of $\frac{1}{4}$ -inch thick felt, and position it on inside of container as in original construction. Stitch new panel (1) to container, $\frac{1}{4}$ of an inch from edge of panel using size FF thread, 6 to 9 stitches per inch and a MD sewing machine.
 - (c) Turn pack right side out, and restitch loosened webbing according to original construction using same machine, thread, and stitch range as above.

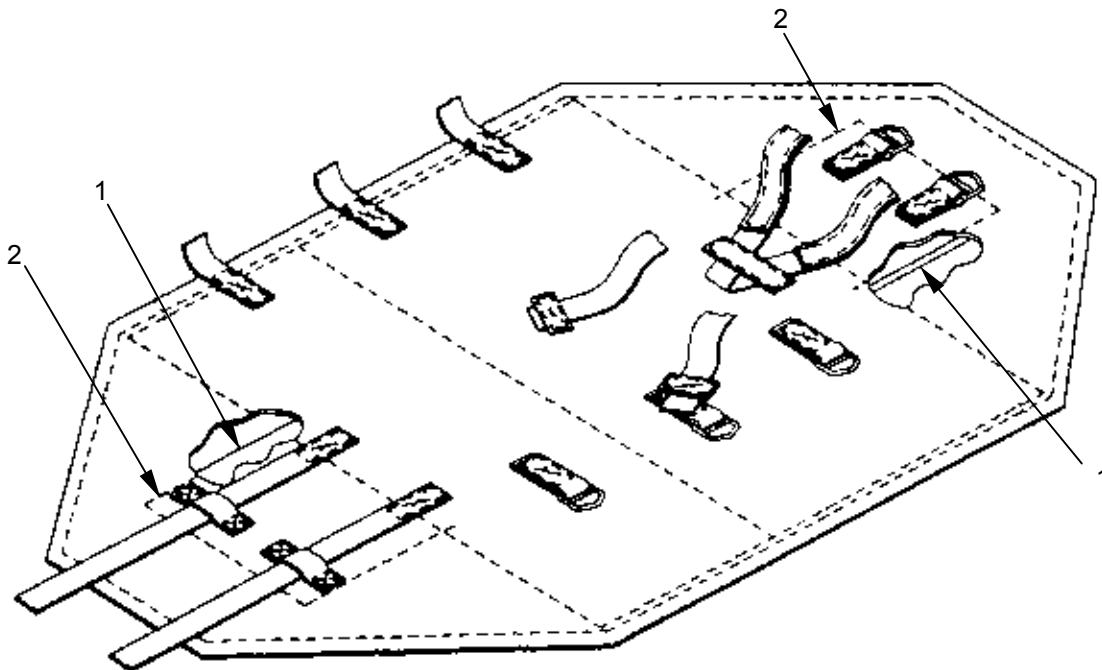

7. Replacing Pack Webbing.

- a. General. All of the webbing items listed in b) through i) below may be replaced. Fabricate each of the items from the prescribed length of Type VIII nylon webbing. Sear ends of nylon webbing smooth and even. Stitch using size FF thread, 6 to 9 stitches per inch and a MD sewing machine.
- b. Upper suspender strap **(1)**. Replace a damaged upper suspender strap **(1)** with a new strap fabricated as described in WP 0053 00 as follows:
 - (1) Cut stitching, and remove suspender strap **(1)** and suspender strap reinforcement **(2)** from pack **(3)**.
 - (2) Fold new strap **(1)** at fold line as shown and sew strap to pack **(3)** with two modified single-X box-stitch **(4)** formations using size FF thread, 6 to 9 stitches per inch and a MD sewing machine.
 - (3) Position suspender strap reinforcement **(2)** over suspender strap **(1)**, and sew reinforcement **(2)** to strap **(1)** and pack **(3)** with a box-stitch formation **(5)** and two hourglass stitch **(6)** formations. Sew as in b) (2) above.
- c. Upper suspender strap reinforcement. Replace damaged upper suspender strap reinforcement with a 9 ½ -inch length of webbing. Cut stitching, and remove damaged reinforcement. Turn under ends of replacement webbing ¾-inch, and sew webbing to suspender strap and container as in b) (2) above and as shown. Sew as in (2) above.

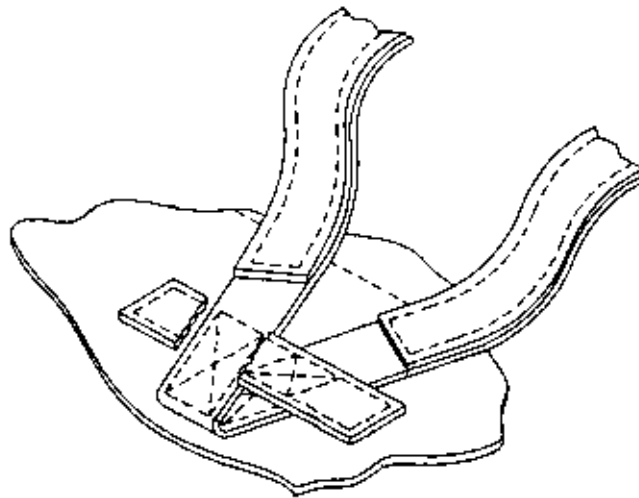

- d. Lower suspender strap. Replace lower suspender strap **(1)** as follows.
- (1) Cut stitching that secures suspender strap **(1)** and strap reinforcement **(2)** to pack.
 - (2) Fabricate new lower suspender strap **(1)** from a 26-inch length of webbing. Sear ends of webbing.
 - (3) Turn end under 1 ½-inch, position on pack as in original construction, and sew a 3-inch single-box stitch **(3)** formation using size FF thread, 6 to 9 stitches per inch and a MD sewing machine.
 - (4) Reposition reinforcement **(2)** over suspender strap **(1)** as in original construction. Sew a single-X box-stitch formation, ¼-inch from edges of webbing. Sew as in (iii).
- e. Lower suspender strap reinforcement **(2)**. Replace damaged lower suspender strap reinforcement with a 4-inch length of webbing. Cut stitching, and remove damaged reinforcement. Turn under edges of replacement webbing ½-inch, and sew webbing to suspender strap and container as in d (4) above.

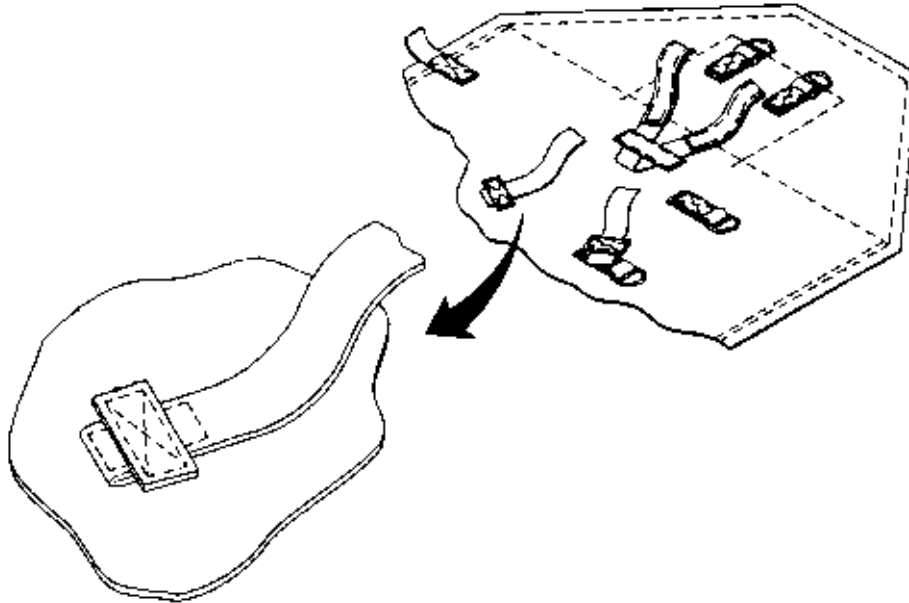

- f. Side securing straps. Replace a damaged side securing strap (1) with a 30-inch length of webbing as follows:

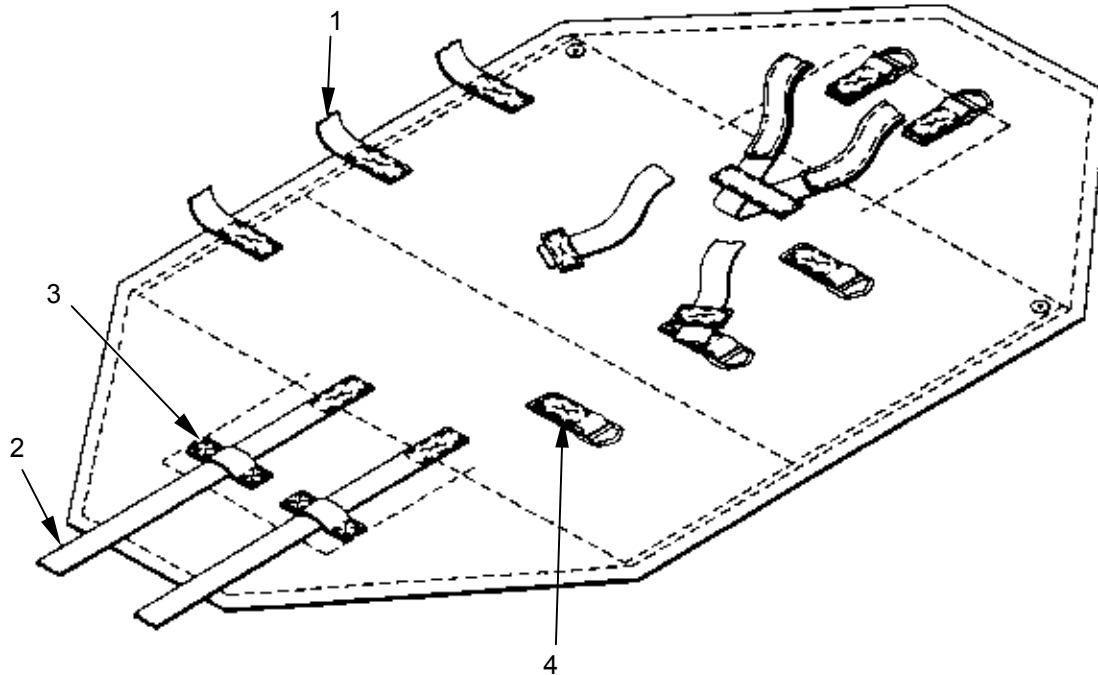

- (1) Cut stitching, and remove damaged strap.
- (2) Cut Type VIII nylon replacement webbing to dimensions shown and sear ends. Sew according to details shown. Use size 3 thread, 5 to 8 stitches per inch and a HD sewing machine.
- (3) Fold end under $\frac{1}{2}$ -inch, position webbing on container as in original construction and sew according to details shown. Sew as above.

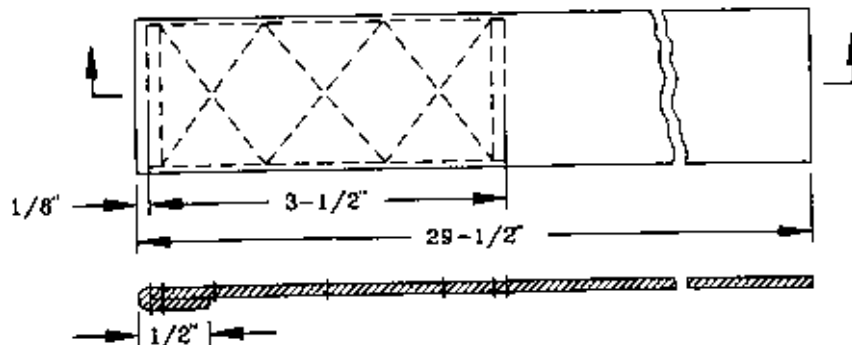

- g. End securing straps. Replace a damaged end securing strap **(2)** with a 60-inch length of webbing. Use procedures in **(f)** above.
- h. Strap guide. Replace a damaged strap guide **(3)** with a 6-inch length of webbing as follows:
 - (1) Cut stitching, and remove damaged strap guide.
 - (2) Turn under ends of replacement webbing 1-inch, position webbing on pack as in original construction, and sew according to details shown. Use size 3 thread, 5 to 8 stitches per inch and a HD sewing machine.

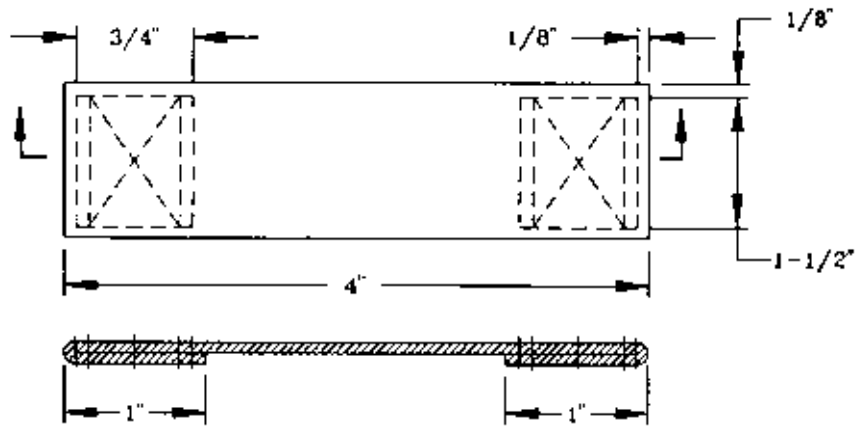

- i. Adapter chap. Replace a damaged adapter chap **(4)** with an 8-inch length of Type VIII nylon webbing as follows:
 - (1) Cut stitching that secures chap **(4)** to pack and remove adapter **(5)**.
 - (2) Position adapter on replacement webbing as shown.
 - (3) Position webbing on pack in original construction, and sew according to details shown. Use size 3 thread, 5 to 8 stitches per inch and a HD sewing machine.

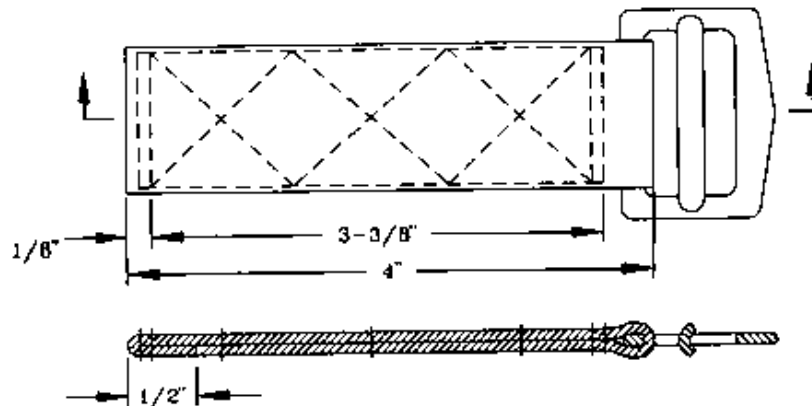

8. Replacing Pack Hardware.

- a. Adapters. Replace a damaged adapter **(1)** with a serviceable like item from stock. Do not attempt to straighten a bent adapter by removing adapter chap. Install serviceable adapter, and fabricate new adapter chap as prescribed in (i) above.
- b. Rivets. Replace a loose or damaged rivet **(2)** with a serviceable rivet and washer from stock. Remove damaged rivet by cutting or filing end of rivet so that it may be withdrawn through fabric. Exercise care in removing rivet so as not to damage fabric. Install new rivet following procedures described in WP 0015 00.

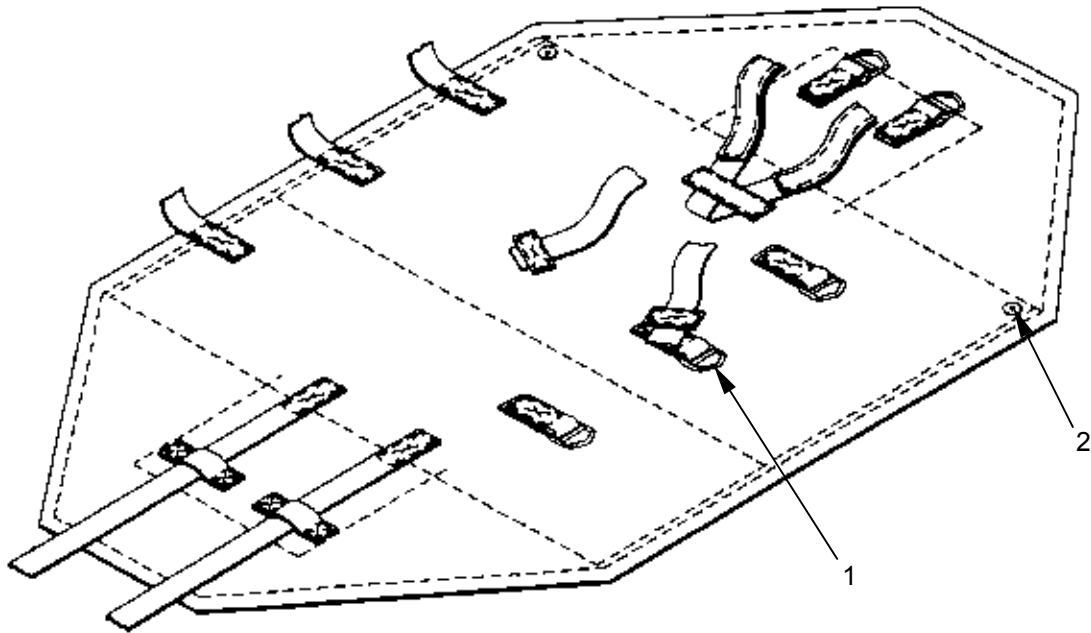

9. Replacing Harness Lowering Line Pocket (1), Pocket Flap (2) and Pocket Tie (3).
- a. Pocket. Replace a damaged lowering line pocket (1) as follows:
- (1) Cut stitching and remove damaged pocket from harness. If pocket flap (2) is not damaged remove flap from pocket.
 - (2) Fabricate pocket as described in WP 0053 00.
 - (3) Turn under raw edges of pocket $\frac{1}{2}$ -inch, and position pocket on harness as in original construction. Sew around pocket $\frac{1}{8}$ -inch from edge using size 3 thread, 5 to 8 stitches per inch and a HD sewing machine.
- b. Pocket flap. Fabricate new pocket flap (2) as specified in WP 0053 00, if necessary.
- c. Pocket ties. Replace a damaged pocket tie (3) with a 14-inch length of $\frac{3}{4}$ -inch length Type I nylon cotton tape. Sear ends of tape and turn under one end of tape $\frac{1}{4}$ -inch. Position this end of tape on edge of lowering line pocket, 2-inches from the top. Sew pocket tie to pocket using size FF thread, 6 to 9 stitches per inch and a MD sewing machine.

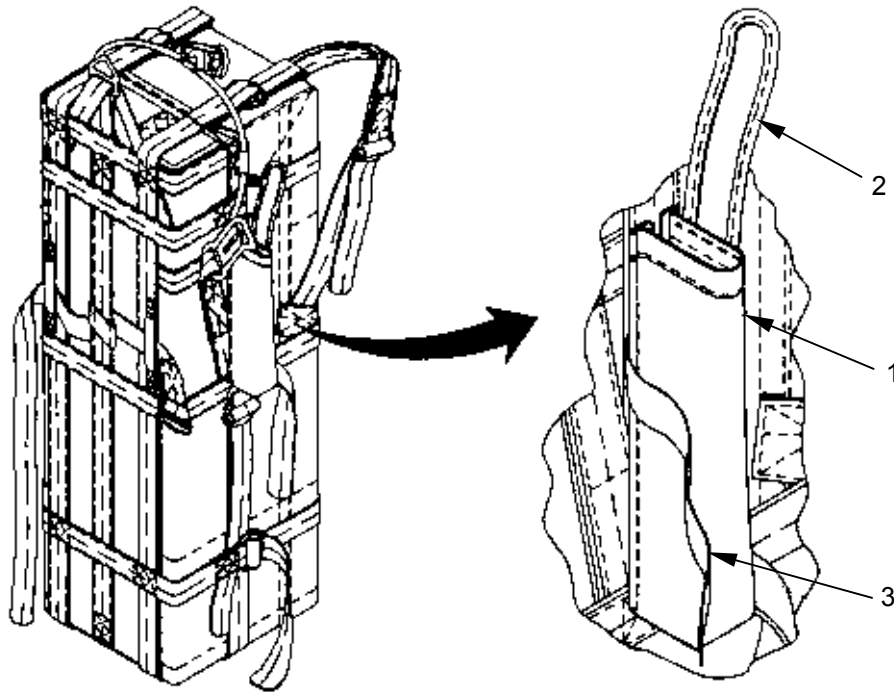

10. Replacing Webbing on Harness.

- a. General. All of the webbing items listed in **(b)** through **(n)** below may be replaced. Unless otherwise specified, fabricate each of the items from the prescribed length of Type VIII nylon webbing and sew using size 3 thread, 5 to 8 stitches per inch and a HD sewing machine. Sear exposed webbing ends.
- b. Upper suspension strap **(1)** and reinforcement **(2)**. Replace a damaged upper suspension strap reinforcement **(2)** with 21 ³/₄-inch length of webbing as follows:
 - (1) Remove reinforcement **(2)** by cutting webbing along edge **(3)** of harness, leaving stitched ends attached.
 - (2) Thread replacement webbing through triangular loop **(4)** and position ends of webbing on harness over old webbing.
 - (3) Sew each end of replacement webbing to harness according to details shown and as stated in 10. a).
- c. Suspension straps **(3)**. Replace a damaged upper suspension strap with a 15-inch length of webbing as follows:
 - (1) Upper suspension strap **(1)**. Replace a damaged upper suspension strap with a 15-inch length of webbing as follows:
 - (a) Remove damaged strap by cutting both thicknesses of webbing along edge **(4)** of harness, leaving stitched ends attached.
 - (b) Pass one end of webbing through triangular loop **(4)** under reinforcement **(2)** as shown and fold end under 7 ¹/₄-inches.
 - (c) Position replacement strap on harness over old webbing with long end extending to leading edge **(5)** of second perpendicular web. Stitch replacement to harness as in 10. a).
 - (2) Lower suspension strap **(6)**. Replace a damaged lower suspension strap as follows:
 - (a) Remove damaged strap by cutting both thicknesses of webbing along edge **(7)** of lower suspension strap reinforcement **(8)**, leaving stitched ends attached. Remove triangular loop.

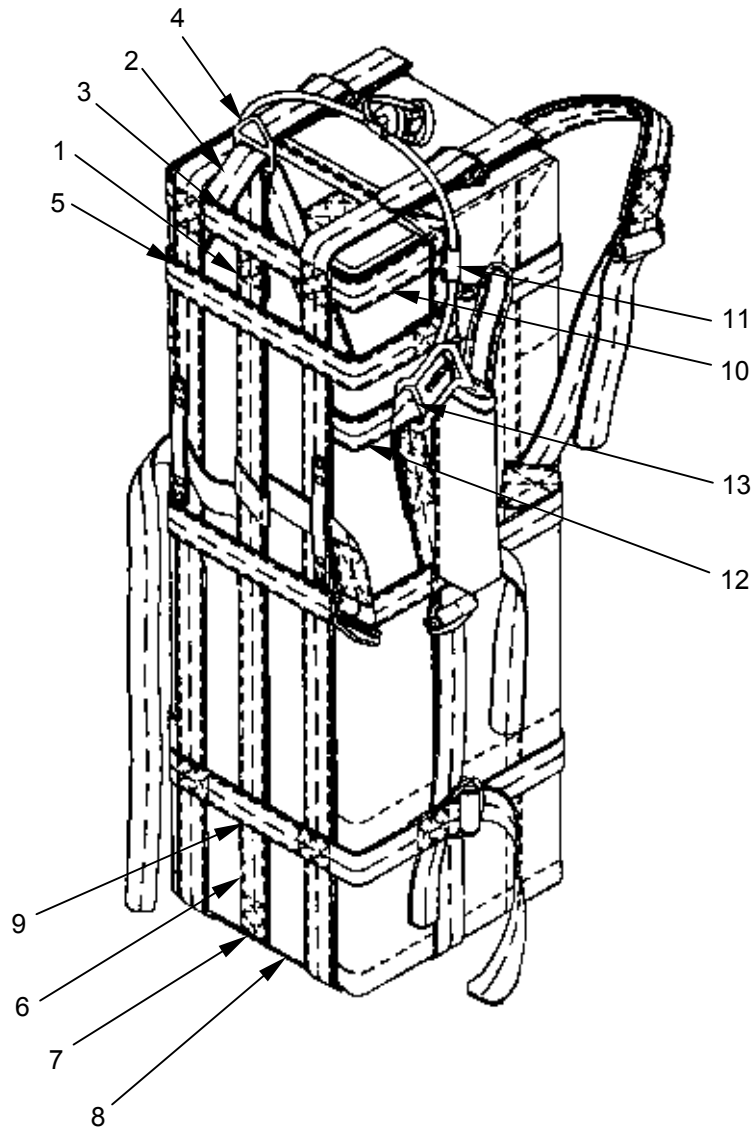

-
- (b) Cut a 14 1/2-inch length of webbing for a replacement strap and a 3 1/2-inch length of webbing for a buffer.
 - (c) Pass one end of replacement strap through triangular loop, and fold under end of strap 5-inches. Position buffer between triangular loop and strap.
 - (d) Position replacement strap on harness over old webbing, with long end extending to leading edge **(9)** of second perpendicular web. Stitch replacement strap to harness. Use size 3 thread, 5 to 8 stitches per inch and a HD sewing machine.
- d. Body reinforcement **(10)**. Replace a damaged body reinforcement with a 25 1/2 inch length of webbing as follows:
- (1) Cut stitching, and remove quick-release retaining loops **(11)**.
 - (2) Position replacement webbing over old webbing, and sew around replacement with a box-stitch formation, 1/8 of an inch from the edge. Use size 3 thread, 5 to 8 stitches per inch and a HD sewing machine.
 - (3) Replace quick-release retaining loops **(11)** according to original construction.
- e. Lower suspension strap reinforcement **(8)**. Replace damaged lower suspension strap reinforcement with a 10-inch length of webbing. Position replacement over old reinforcement, and sew around replacement with a box-stitch formation, 1/8-inch from edge. Use size 3 thread, 5 to 8 stitches per inch and a HD sewing machine.
- f. Fastener chap reinforcement **(12)** Replace damaged fastener chap reinforcement with a 7-inch length of webbing as follows:
- (1) Cut stitching that secures fastener chap **(13)** to reinforcement.
 - (2) Position replacement over old reinforcement, and sew around replacement with a box-stitch formation, 1/8-inch from edge. Restitch fastener chap according to original construction. Use size 3 thread, 5 to 8 stitches per inch and a HD sewing machine.

- g. Handle strap. The handle, adapter, and running end portions of the handle strap may be replaced.
- (1) Handle portion **(1)**. Replace damaged handle portion of handle strap as follows:
- (a) Remove cable and conduit assembly **(2)**, lowering line **(3)**, and quick-release retaining loops **(4)**.
 - (b) Remove handle **(1)** by cutting webbing along edge of harness **(5)**.
 - (c) Fabricate new handle according to details in WP 0053 00.
 - (d) Position replacement handle on harness, and sew using size 3 thread, 5 to 8 stitches per inch and a HD sewing machine.
 - (e) Replace quick-release retaining loops **(4)** according to original construction. Replace cable and conduit **(2)** assembly.

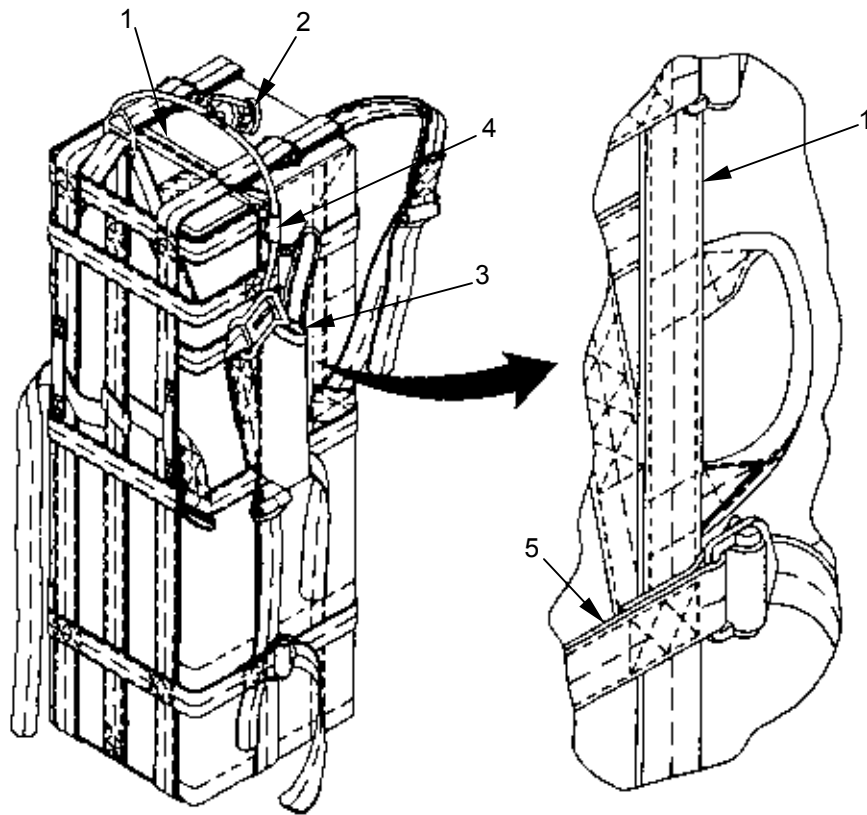

- (2) Adapter portion (1). Replace damaged adapter portion of handle strap (2) with a 14 1/2-inch length of webbing as follows:
- (a) Cut strap along edge (3) of harness, and remove adapter (4).
 - (b) Cut stitching, and remove lowering line pocket (5).
 - (c) Pass one end of replacement webbing through adapter and fold end under 2 1/2-inches.
 - (d) Position webbing on harness, with long end extending to leading edge (6) of second perpendicular web. Stitch webbing to harness using size 3 thread, 5 to 8 stitches per inch and a HD sewing machine.
 - (e) Replace lowering line pocket as described in 9 above.

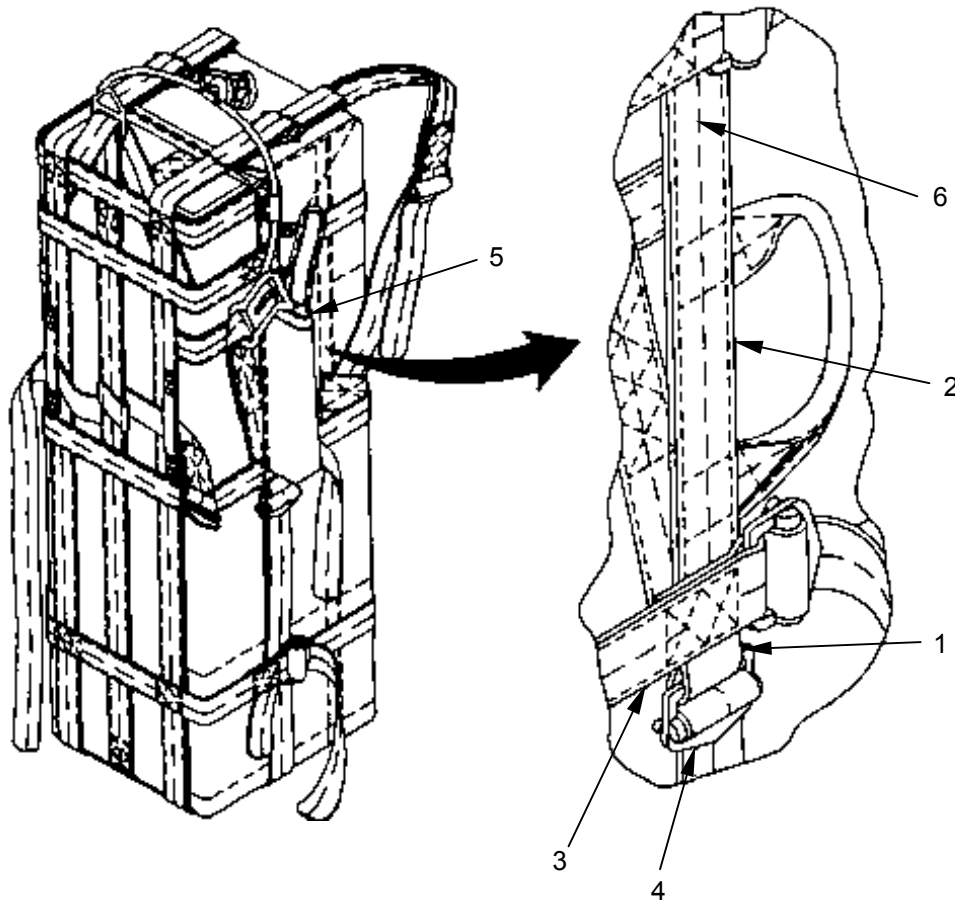

- (3) Running end portion (1). Replace damaged running end portion of handle strap (2) with a 76-inch length of webbing as follows:
- Remove damaged end by cutting strap along edge (3) of harness.
 - Round one end of replacement webbing, and dip end in wax to a depth of 2-inches.
 - Position webbing on harness, with straight end extending to leading edge (4) of second perpendicular web. Sew webbing to harness using size 3 thread, 5 to 8 stitches per inch and a HD sewing machine.

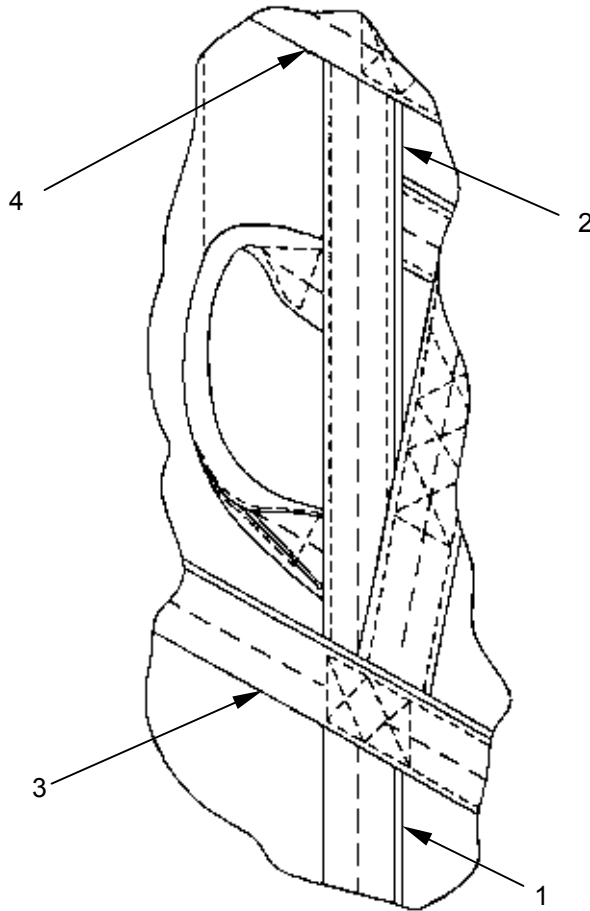

- h. Securing strap adapter ends **(1)**. Replace damaged adapter end of securing strap as in 1) or 2) below.
- (1) Cut a piece of webbing 2 1/2-inches longer than distance from adapter **(2)** to leading edge **(3)** of second perpendicular web.
 - (2) Remove damaged end by cutting strap along edge **(4)** of harness, and remove adapter **(2)**.
 - (3) Pass one end of replacement webbing through adapter **(2)**, and fold end under 2 1/2-inches. Position replacement on harness, and sew using size 3 thread, 5 to 8 stitches per inch and a HD sewing machine.

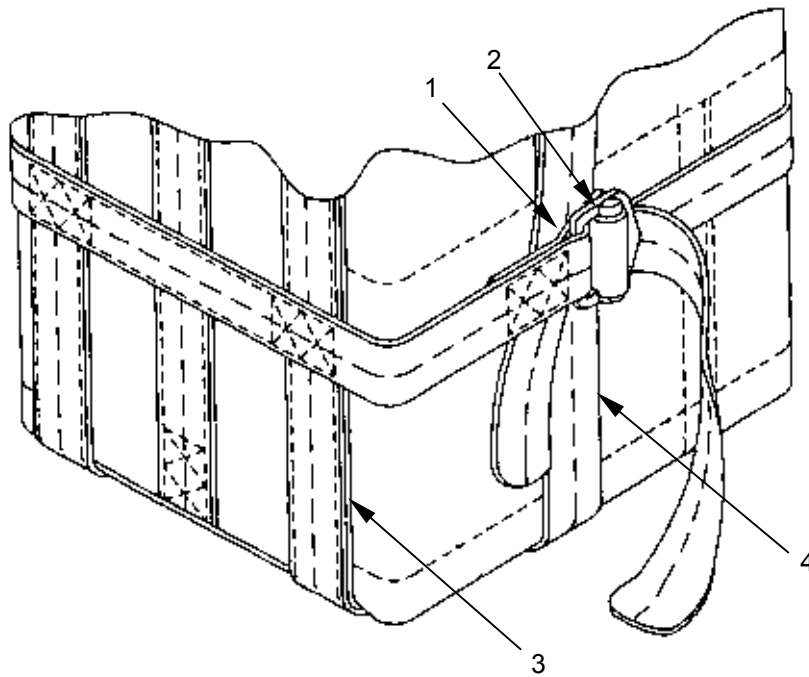

- i. Securing strap running ends (1). Replace damaged running ends of securing strap (2) or end securing strap as follows:
- (1) Remove damaged end by cutting strap along edge of harness.
 - (2) Cut a length of webbing equal to length of end removed plus distance from edge of harness to leading edge (3) of second perpendicular web.
 - (3) Sear exposed ends of nylon webbing smooth and even.
 - (4) Position webbing on harness, with straight end extending to leading edge of second perpendicular web. Sew webbing to harness using size 3 thread, 5 to 8 stitches per inch and a HD sewing machine.

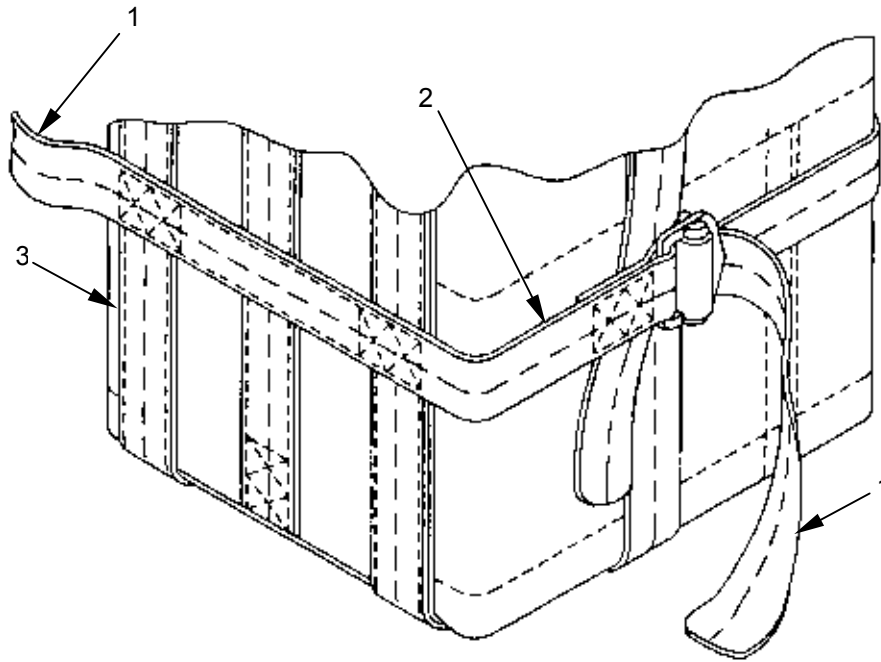

- j. Leg strap. Replace a damaged leg strap **(1)** with a 41 ½ inch length of webbing as follows:
- (1) Cut stitching **(2)**, and remove leg strap from harness. Remove adapter **(3)** and buffer **(4)**. If buffer is damaged, replace it with a 3 ½-inch length of webbing.
 - (2) Sear exposed ends of nylon webbing smooth and even. Pass straight end of replacement webbing through adapter, and fold under end of webbing, 3 ¾-inches. Position buffer between adapter and strap, and sew using size 3 thread, 5 to 8 stitches per inch and a HD sewing machine.
 - (3) Pass replacement webbing under suspension strap from right to left, leaving 7 ¾-inches of webbing between adapter end of replacement and suspension strap. Pass replacement webbing back over and under suspension.
- k. Leg strap guide **(5)**. Replace a damaged leg strap guide with a 6-inch length of webbing as follows:
- (1) Align edges of webbing, and sew them together 1/8 of an inch from edge. Use size 3 thread, 5 to 8 stitches per inch and a HD sewing machine.
 - (2) Cut stitching **(6)**, and remove damaged guide from harness.
 - (3) Position replacement guide **(5)** on harness with sewn edge to the inside as in original construction and sew as in (i) above.

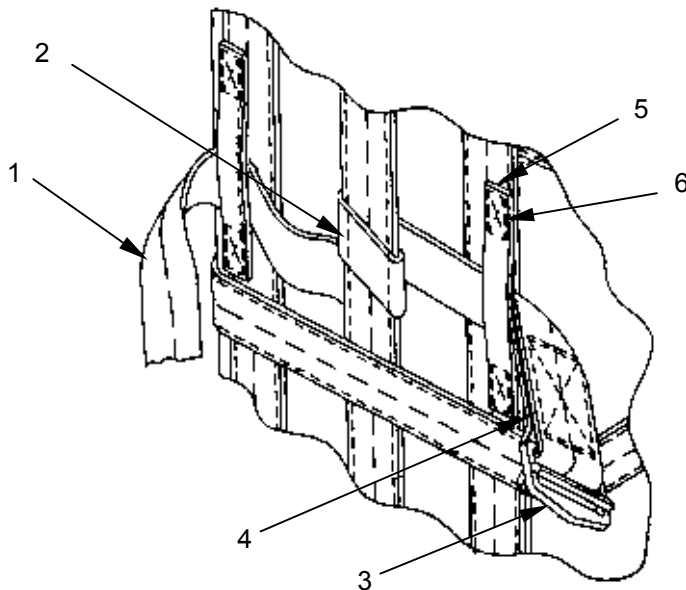

- I. Handle. Replace a damaged handle **(1)** with a 15 ½-inch length of webbing as follows:
- (1) Remove handle **(1)** by cutting stitching **(2)** that secures handle to harness. Cut sufficient stitching so that replacement handle may be inserted between webbing and cotton duck and sewed to the duck without difficulty, if handle on lowering line pocket side of harness is damaged, remove pocket.
 - (2) Fabricate handle **(1)** according to details in WP 0053 00.
 - (3) Position handle **(1)** on harness as in original construction, and sew using size 3 thread, 5 to 8 stitches per inch and a HD sewing machine.
 - (4) Restitch loosened stitching **(2)** according to original construction. If lowering line pocket has been removed, replace it according to original construction.
- m. Quick-release retaining loop. Replace a quick-release retaining loop with a 3-inch length of webbing. Cut stitching, and remove damaged loop. Sew replacement loop to handle strap using size 3 thread, 5 to 8 stitches per inch and a HD sewing machine.

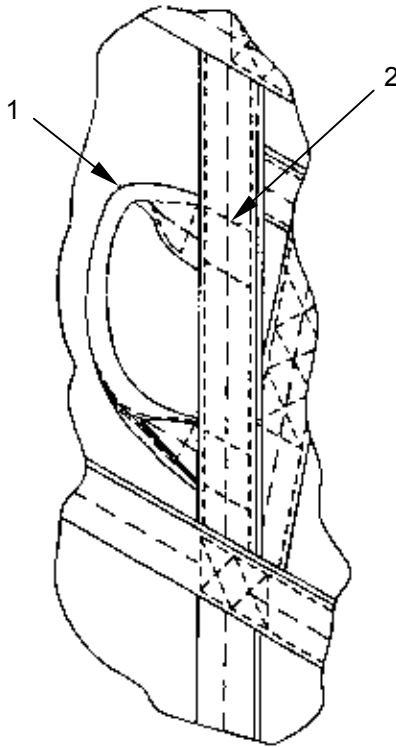

- n. Keeper pin strap. Replace a damaged keeper pin strap (1) with a 13-inch length of 1-inch Type IV nylon webbing as follows:
- (1) Remove damaged keeper pin strap (1) from cable and conduit assembly (2), and remove keeper pin (3) from keeper pin strap (1).
 - (2) Sear ends of replacement webbing.
 - (3) Pass one end of webbing through keeper pin, fold end under 2-inches and sew using Size E thread, 7 to 11 stitches per inch and a LD sewing machine.
 - (4) Pass other end of webbing through cable and conduit assembly, fold end under 2-inches, and sew according to details shown. Use same machine, thread and stitch range as in (iii) above.
- o. Replacing harness hardware.
- (1) Keeper pin (3). Replace a bent, sprung, burred or nicked keeper pin with a serviceable like item from stock. Open damaged pin, and remove it from keeper pin strap. Thread strap loop into place between forks of new pin.

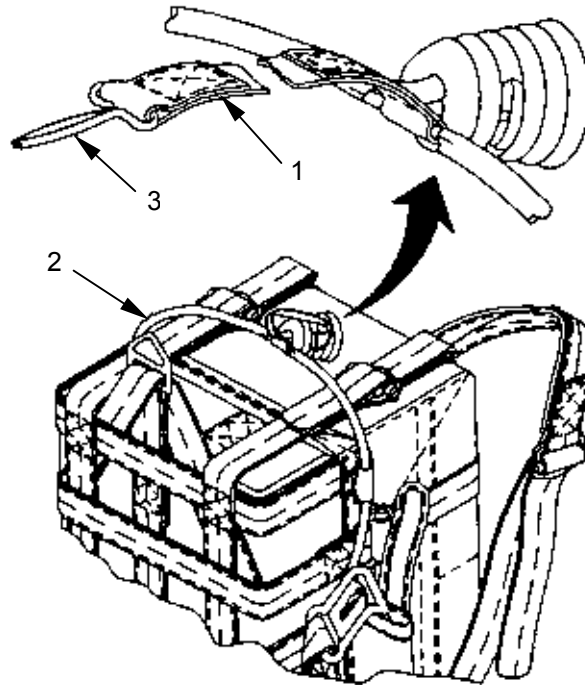

p. Cable and conduit assembly.

- (1) Removal. Unscrew push-pull actuator assembly (1) from release fasteners (2) as shown, and withdraw assembly through quick-release retaining loop (3).
- (2) Installation.
 - (a) Position a 20 x 10-inch preformer, using a rigid wooden or paperboard box, in the top part of the harness and secure with two "F" web straps as shown.

WARNING

Failure to correctly position release knob could result in a safety hazard. If the knob is in the up position it could interfere with the parachutist's reserve parachute.

- (b) With the words "Pull to Release" on the actuator knob facing up, insert the push-pull actuator assembly through the retaining loops in both sides of the harness and attach to release fastener with nuts. Remove preformer.

NOTE

When tightening the nuts, assure that the release fasteners are not twisted away from the harness. When the nuts are fully tightened the actuator knob should be in position shown.

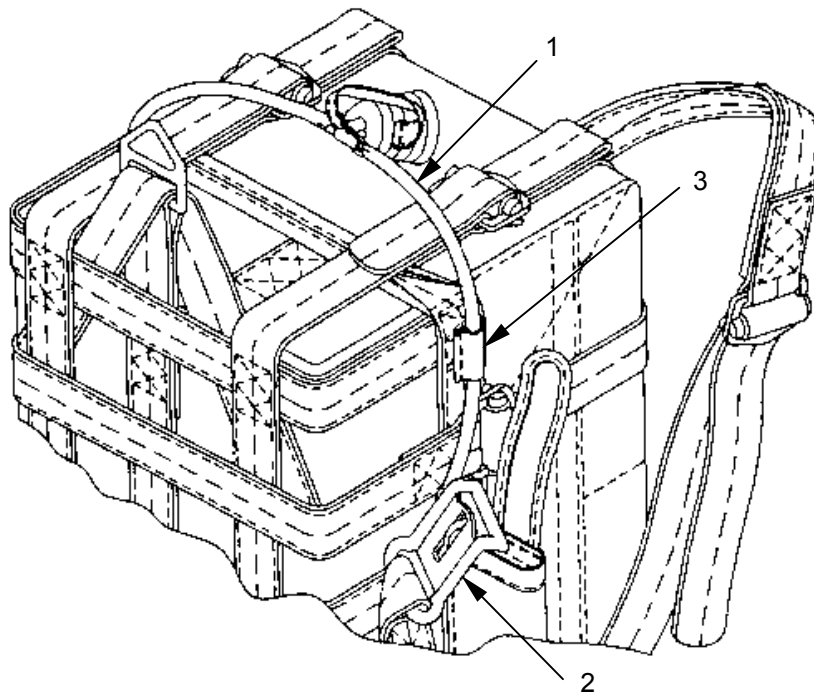

- q. Other items of hardware. Replace other damaged items of hardware on the harness with serviceable like items from stock. Do not attempt to straighten bent hardware or otherwise repair cracked or broken hardware. When it is necessary to cut any stitching to remove damaged hardware from webbing, replace hardware and webbing following procedures in the appropriate section of subparagraph d. above. Do not restitch the webbing.

END OF WORK PACKAGE

UNIT MAINTENANCE

ANCILLARY EQUIPMENT FOR PERSONNEL PARACHUTE SYSTEM

JUMP PACK, STINGER MISSILE
INSPECT, REPAIR, REPLACE

INITIAL SETUP:

Tools

Compressing Tool ((WP 0034 00, Table 2, Item 2)
 Knife (WP 0034 00, Table 2, Item 6)
 Knife, Hot Metal (WP 0034 00, Table 2, Item 7)
 Needle, Tacking (WP 0034 00, Table 2, Item 9)
 Pot, melting (WP 0034 00, Table 2, Item 10)
 Sewing Machine, Darning (WP 0034 00, Table 2, Item 15)
 Sewing Machine, HD (WP 0034 00, Table 2, Item 16)
 Sewing Machine, MD (WP 0034 00, Table 2, Item 18)
 Shears (WP 0034 00, Table 2, Item 20)

Personnel Required

92R(10) Parachute Rigger

Equipment Condition

Stinger Missile Pack should be clean and dry.
 Place Pack on worktable.

Materials/Parts

Beeswax, Technical, 1-Lb Cake (WP 0052 00, Table 1, Item 1)
 Cloth, duck, nylon (WP 0052 00, Table 1, Item 9)
 Cord, fibrous, nylon, red (WP 0052 00, Table 1, Item 11)
 Felt, 1/4-inch (WP 0052 00, Table 1, Item 17)
 Sleeve, swaging (WP 0052 00, Table 1, Item 28)
 Tape, fastener, hook, 1-inch wide (WP 0052 00, Table 1, Item 34)
 Tape, fastener, pile, 1 1/2-inch wide (WP 0052 00, Table 1, Item 35)
 Tape, textile, Type IV (WP 0052 00, Table 1, Item 45)
 Thread, nylon, size 3 (WP 0052 00, Table 1, Item 47)
 Thread, nylon, size 5 (WP 0052 00, Table 1, Item 48)
 Thread, nylon, size E (WP 0052 00, Table 1, Item 50)
 Thread, nylon, size FF (WP 0052 00, Table 1, Item 51)
 Wax, Paraffin, Type I, Technical (WP 0052 00, Table 1, Item 52)

Webbing, Nylon, Type II (WP 0052 00, Table 1, Item 57)
 Webbing, Nylon, Type III (WP 0052 00, Table 1, Item 69)
 Webbing, Nylon, Type VIII (WP 0052 00, Table 1, Item 61)
 Webbing, Nylon, Type X (WP 0052 00, Table 1, Item 62)
 Webbing, Nylon, Yellow, Type VIII (WP 0052 00, Table 1, Item 70)
 Wire, rope (WP 0052 00, Table 1, Item 76)

INSPECT

Perform a before and after technical/rigger type inspection of the Stinger Missile Pack as outlined in WP 0008 00.

REPAIR

The nylon duck material of the pack body may be restitched, darned, and patched. The polyester felt material may be restitched and plugged as described below.

1. Restitching. Restitch the pack fabric **(1)** directly over old stitching using stitching specifications outlined in the appropriate repair procedures. Lock stitching at least $\frac{1}{2}$ -inch.
2. Darning. Darn a hole or tear in the pack fabric that does not exceed 1-inch in length or diameter using size E or FF thread and a darning machine. There is no limit to darns that may be applied, provided they do not weaken or reduce the original strength of the fabric more than 10%. If damage is in the lined portion of the pack body and only the cotton duck is damaged, darn through duck and felt. If felt is also damaged, remove damaged area before darning duck fabric. Then plug felt as in 3. c) below.
3. Patching. There is no limit to the number of times the pack body may be patched. Patch a hole or tear that exceeds 1-inch in length or diameter following procedures in a) or b) below. Use cotton duck cloth according to original construction for patching outside, and $\frac{1}{4}$ -inch thick felt for plugging inside lining. Use a HD sewing machine, size FF thread, and 6 to 9 stitches per inch.
 - a. To patch a lined portion of the pack **(1)** when the felt **(2)** is not damaged, cut nylon duck patch **(3)** 2-inches beyond circumference of damaged portion. Turn under edges of patch $\frac{1}{2}$ -inch and center patch **(3)** over damaged area. Sew patch to pack **(1)** with a double row of stitching **(4)** as shown.

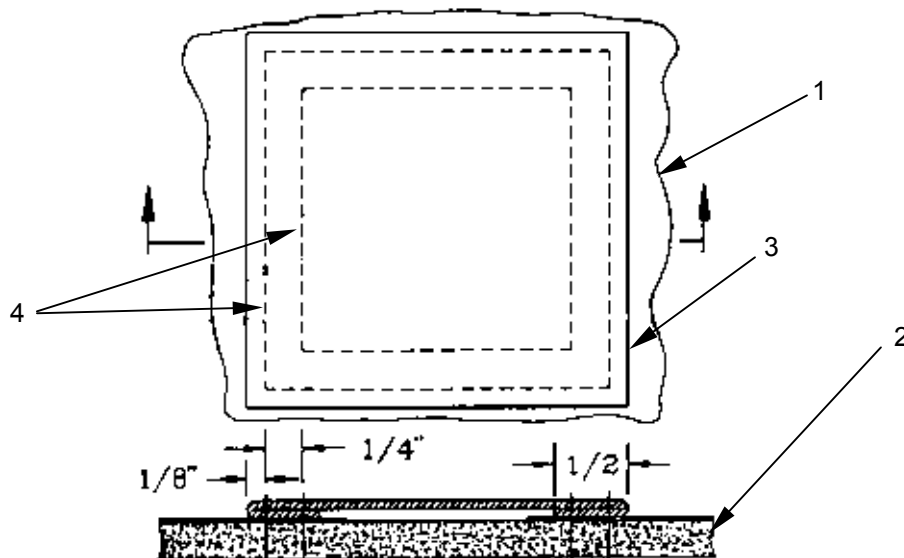

- b. To patch a lined portion of the pack (1) when the felt (2) is damaged, remove the damaged felt as described in c) below. Cut a piece of felt the same size as the piece removed, and position felt plug and cotton duck patch (3) (with edges turned under 1/2-inch) over damaged area. Sew a single box X stitch (4) formation as shown.

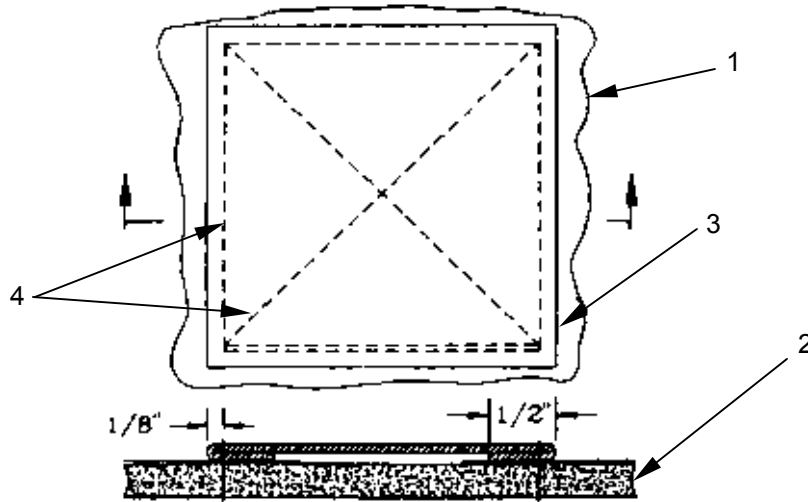

- c. To plug the felt (1) lining of pack, mark a rectangle around the damaged area. Remove the damaged felt while being careful not to damage the nylon duck material (2). Cut a piece of felt the size of the piece removed. Position felt plug into area cleared and sew as shown.

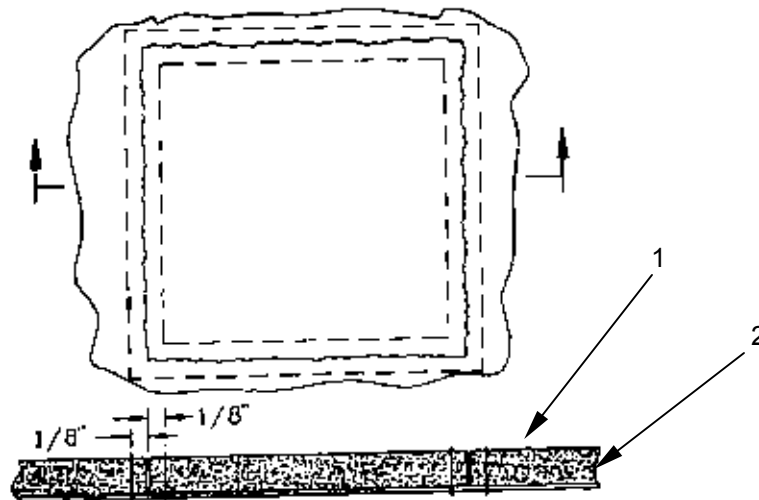

- d. If damage is in an area that cannot be sewed by machine, tack felt (1) plug securely to cotton duck (2) as shown using doubled and waxed size 3 nylon thread. Secure thread ends with suitable knot.

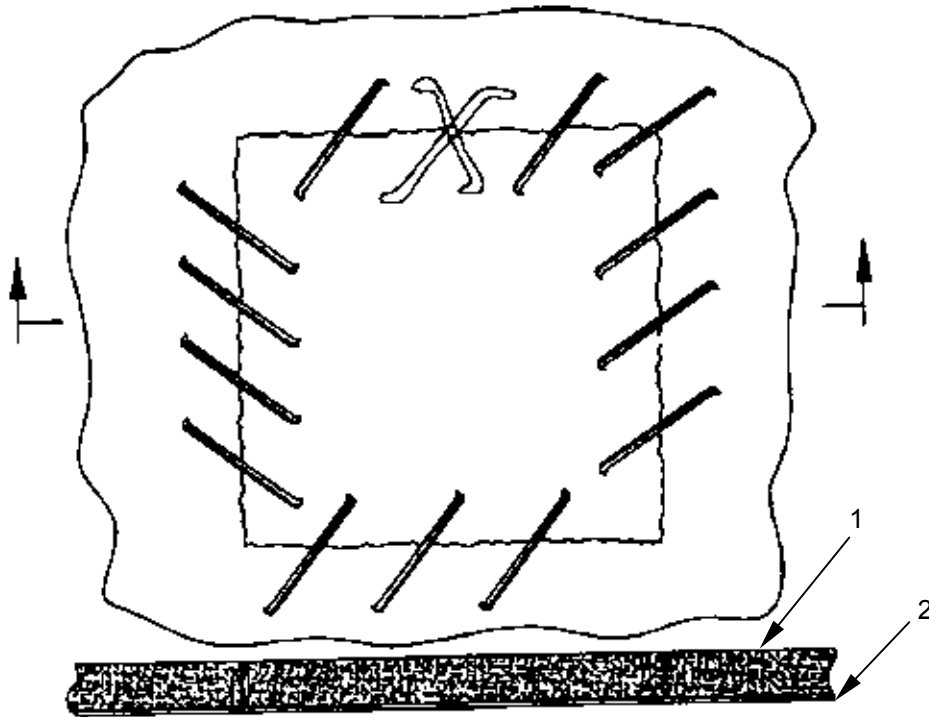

4. Repair of Binding Tape. Overlap the binding tape, extending the new tape at least 1-inch beyond the damaged tape. Stitch tape with two rows of stitching $\frac{1}{8}$ and $\frac{1}{4}$ -inches from edge of tape as in original construction using size FF thread, 6 to 9 stitches per inch and a HD sewing machine.
5. Repairing Webbing. The webbing on the pack may be restitched. Restitch loose, broken, or defective stitching according to original construction details and as outlined in the appropriate repair procedures.

REPLACE

Replacing Webbing. All webbing items may be replaced. Replacement will be accomplished in accordance with the original construction and as prescribed herein. Sear all cut ends of webbing before assembling webbing on pack.

NOTE

Splicing of the lowering line and attaching web is not authorized. Darning of the attaching web is not authorized.

1. Lowering line. Replace lowering line as described in WP 0018 00.
2. Ring Strap Assembly, O-Ring, and O-Ring Chape.

NOTE

Some packs may be equipped with O-Rings in lieu of D-Rings. Replace D-Rings if damaged, with O-Rings.

- a. O-Ring and O-Ring Chape.
 - (1) Cut stitching from Type III nylon retaining strap, **(1)** and remove strap. Replace with a 6-inch length of Type III nylon webbing if damaged. Sew box X stitching using size 5 thread, 4 to 6 stitches per inch and a HD sewing machine.
 - (2) Cut stitching from Type III nylon webbing which secures the O-ring **(2)** to the chape **(3)**. Replace damaged webbing with a 5 $\frac{1}{2}$ -inch length of Type III nylon webbing. Sew as in 1 above. Replace D-Ring with a serviceable O-Ring of the same type.

b. Ring Strap Assembly.

- (1) Cut stitching from Type III nylon webbing following steps a. 1 and 2 above. Set aside webbing and O-Rings.
- (2) Cut stitching from ring strap assembly (4) and remove. Replace ring strap assembly with a 10-inch length of Type X woven nylon webbing. Sew as in original construction using size 3 thread, 5 to 8 stitches per inch and a HD sewing machine.

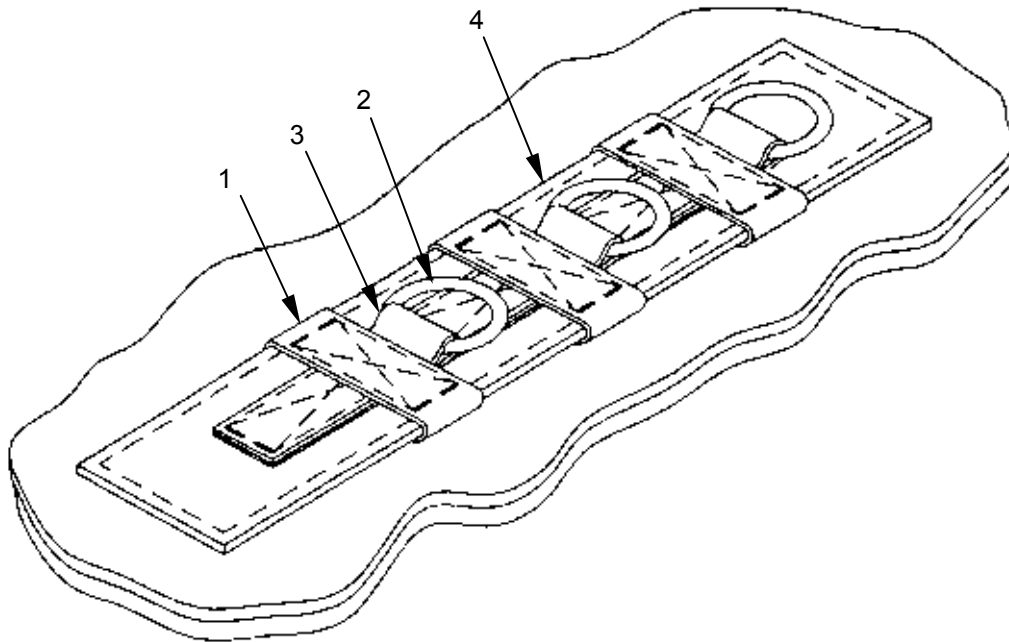

3. Carrying Handle Strap. Replace damaged carrying handle strap as follows:
 - a. Remove the damaged handle **(1)** by cutting and removing stitching of the two 2-inch box X patterns **(2)** that secure handle to the pack, and discard the damaged handle **(1)**.
 - b. Fabricate new handle of Type VIII woven nylon webbing according to details in WP 0053 00.
 - c. Turn under ends 1 ¹/₄-inch and position replacement strap in the original position of the handle. Sew using size 3 thread, 5 to 8 stitches per inch and a HD sewing machine.

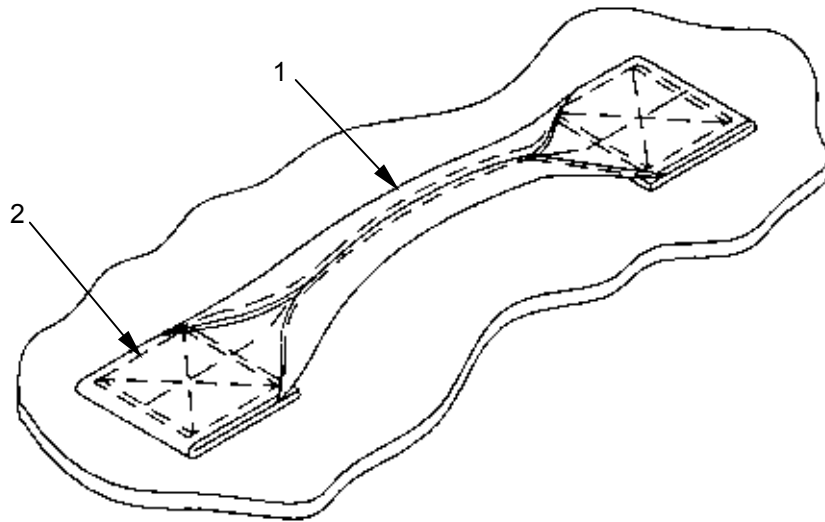

4. Side Securing Straps (running ends). Replace damaged running end of side securing strap as follows:
 - a. Cut strap (1) along stitching that secures strap to pack (2).
 - b. Cut a length of Type VIII nylon webbing equal to the length removed plus 3 1/2-inches. Sear ends.
 - c. Turn under one end 1/2-inch, and position replacement strap 3-inches beyond the cut webbing (3) end on the pack. Stitch with 3 point WW pattern as shown using size 3 thread, 5 to 8 stitches per inch and a HD sewing machine.

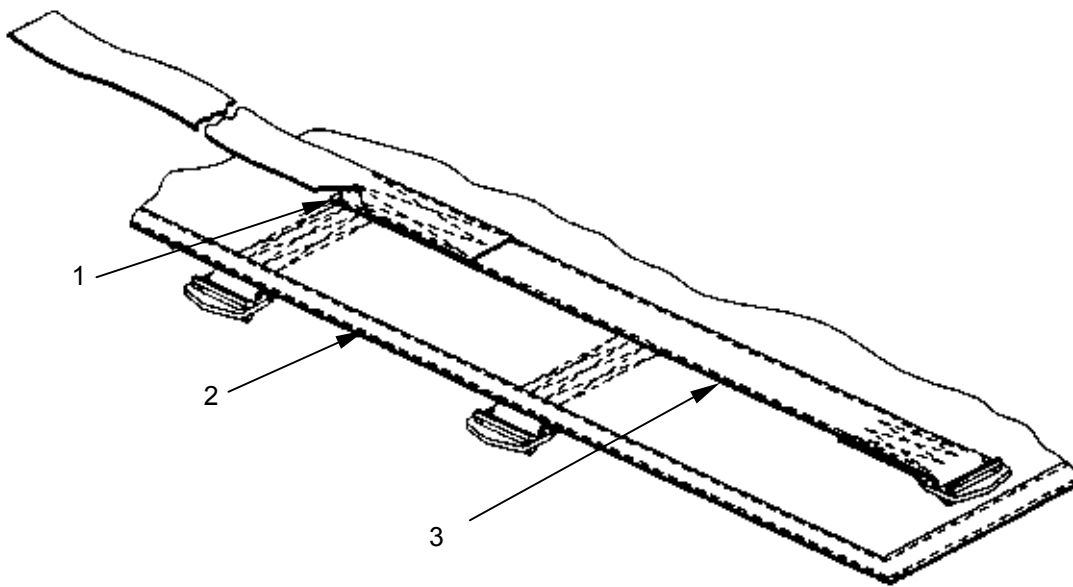

5. Side Securing Strap Quick Fit Adapters. Replace damaged hardware as follows:
 - a. Remove adapter **(1)** by cutting the webbing chape **(2)** as close to the 3-point WW stitch pattern **(3)** as possible. Discard adapter.
 - b. Cut a 3 ³/₄-inch buffer of Type VIII nylon webbing and fold so ends are offset ¹/₂-inch.
 - c. Cut a 7 ¹/₂-inch adapter chape of Type VIII nylon webbing. Fold Webbing ¹/₂ and 3 ³/₄-inches from one end.
 - d. Place buffer and chape on serviceable adapter, position replacement on top of original, and sew with a 3-inch 3 point WW stitch formation using size 3 thread, 5 to 8 stitches per inch and a HD sewing machine.

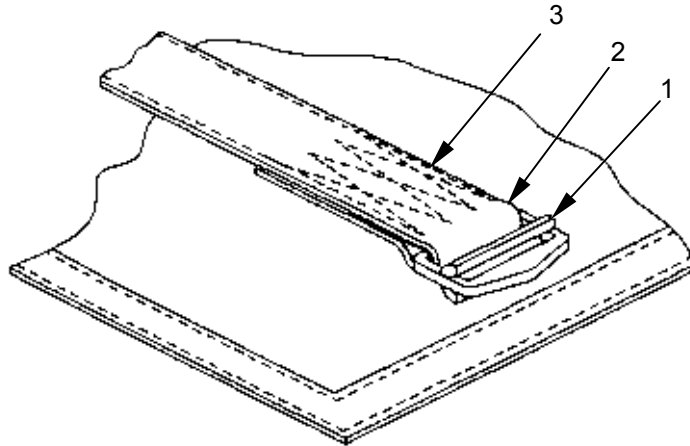

6. Forward End Securing Straps and Heavy Duty Adapters. Replace damaged forward end securing straps **(1)** and heavy duty adapters **(2)** as follows:
 - a. Remove damaged strap **(1)** by cutting along stitching **(3)** that secures strap to pack. Replace strap with a length of Type X nylon webbing equal to the length removed. Replace damaged adapter **(2)** with serviceable adapter of the same type.
 - b. Fold the webbing around the heavy-duty quick fit adapter **(2)** and position strap **(1)** on the pack in its original position, as shown. Stitch with 3-inch three point WW pattern as shown **(3)** using size 5 thread, 4 to 6 stitches per inch and an HD sewing machine.

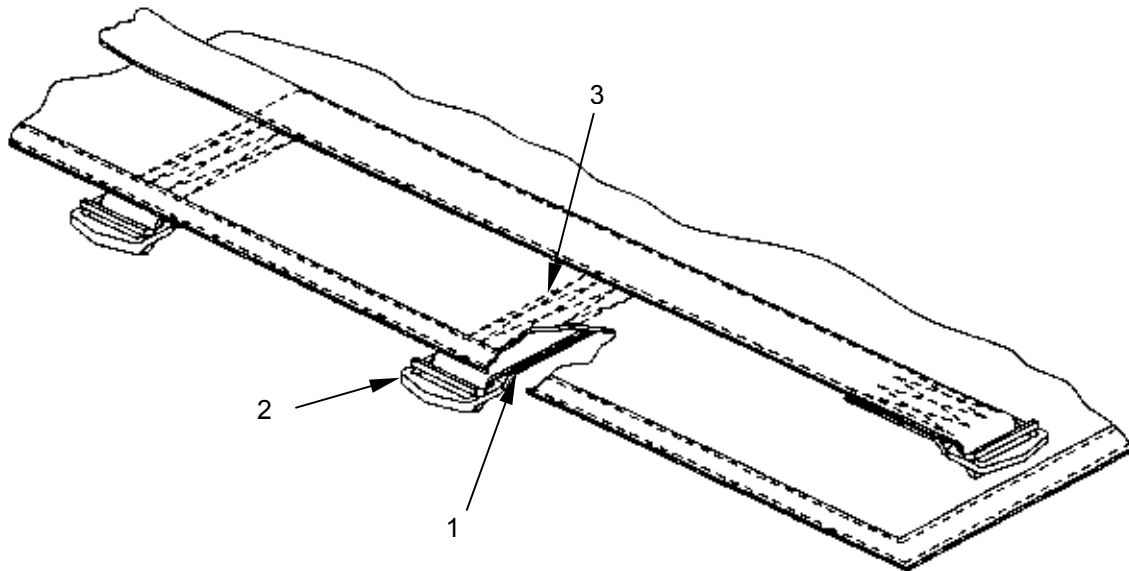

7. Aft End Securing Straps.

- a. Remove damaged aft end securing straps (1) by cutting along stitching (2) that secures straps to pack.
- b. Cut two lengths of type X nylon webbing equal to the lengths removed.
- c. Stitch the two lengths of webbing together, as in original, with a 2-inch double box X stitch (3) formation. Use size 5 thread, 4 to 6 stitches per inch and an HD sewing machine.
- d. Position the four free running ends of the replacement straps, as shown and stitch to the pack body with 3-inch three point WW stitch formation. Stitch as in (c) above.

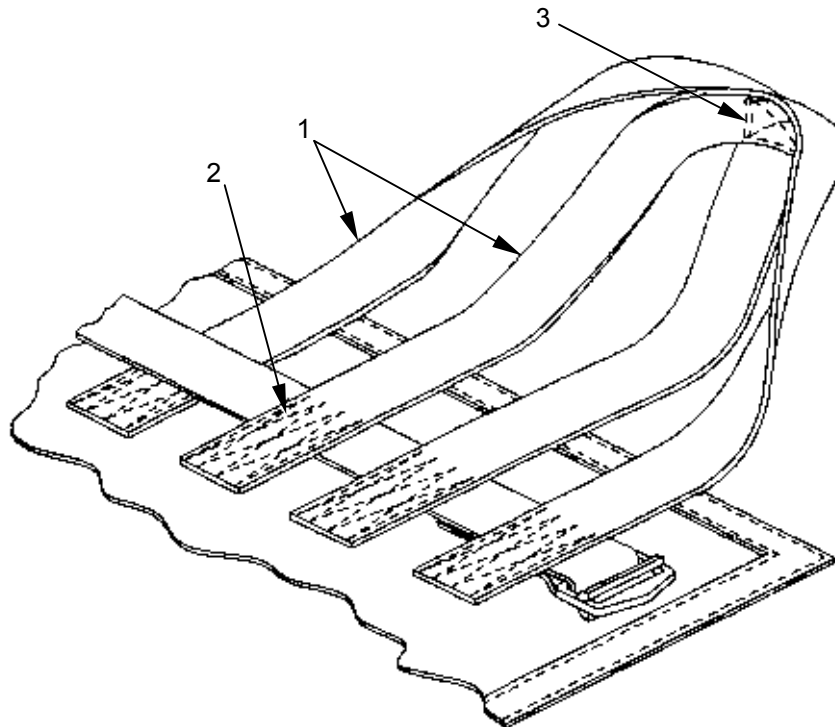

-
8. Chest Tiedown Assembly. Replace a damaged tiedown strap, D-Rings, grommet, Type III nylon loop, or chape as follows:
- a. Chest tiedown strap. Replace a damaged or missing tiedown strap **(1)** as follows:
 - (1) Remove the damaged strap **(1)** from the D-Rings **(2)** and chape.
 - (2) Cut a 36-inch length of Type III nylon webbing, sear one end, and stitch a 4-inch loop **(3)** in the other end using two bartacks. Use size E thread, 7 to 11 stitches per inch and a MD sewing machine.
 - (3) Route the replacement webbing through the D-Rings **(2)**.
 - b. D-Rings and Type III nylon loop. Replace damaged D-Ring **(2)**, and/or Type III nylon loop **(4)** as follows:
 - (1) Remove tiedown strap **(1)** from pack and set aside. Cut stitching on the chape **(5)** and remove and discard damaged D-Ring, and/or Type III nylon loop. Replace damaged Type III nylon loop **(4)** with a 5-inch piece of Type III nylon cord, red 21105. Replace a damaged D-Ring **(2)** with serviceable D-Ring of the same type.
 - (2) Sew to pack as shown and with box X stitch. Use size E thread, 7 to 11 stitches per inch and a MD sewing machine.
 - c. Chape **(5)** and grommet **(6)**. Replace damaged chape and grommet as follows:
 - (1) Remove tiedown strap **(1)** from pack and set aside. Cut stitching on the chape **(5)** and remove chape from D-Rings **(2)** and Type III nylon loop. Set components aside.
 - (2) Cut an 8 $\frac{1}{8}$ -inch length of Type III nylon webbing, fold over two D-Rings and Type III nylon loop. Remove damaged grommet and install a new one as described in WP 0015 00.
 - (3) Hand tack and position the replacement chape as shown.
 - (4) Route tiedown strap around D-Rings.

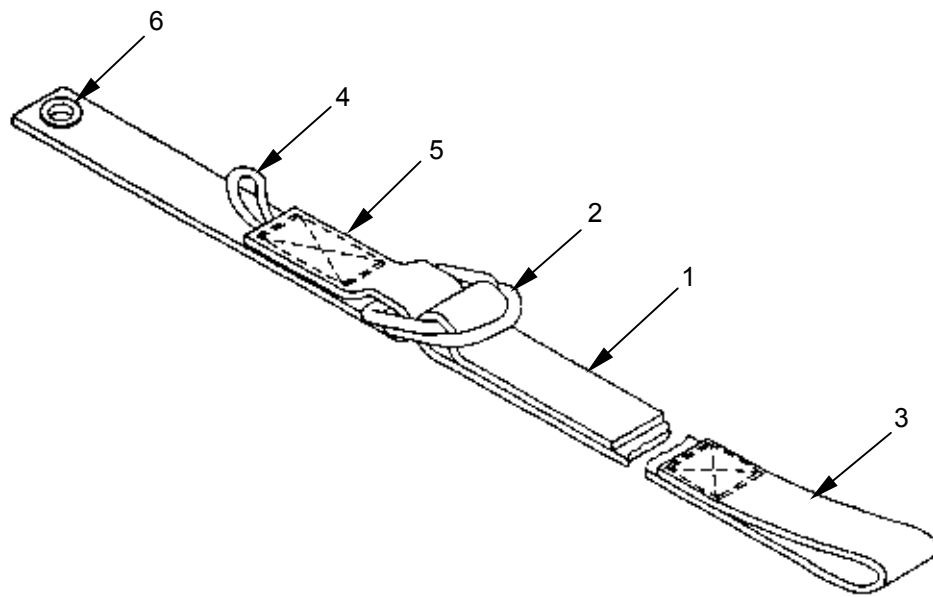

9. Leg Tiedown Assembly. Replace a damaged tiedown strap, D-Rings, grommet, Type III nylon loop, or chape as follows:
 - a. Leg tiedown strap. Replace the leg tiedown strap following paragraph 8. a) above, except cut a 60-inch length of bulked 1-inch nylon webbing in lieu of the 36-inch length.
 - b. D-Rings, and Type III nylon loop. Replace a damaged D-Ring, and/or Type III nylon loop following paragraph 8. (b) ensuring that the new chape is routed under the cable guide assembly strap as shown.
 - c. Grommet and Chape. Replace damaged grommet and/or chape following paragraph 8. c) ensuring that the new chape is routed under the cable guide assembly strap as shown.

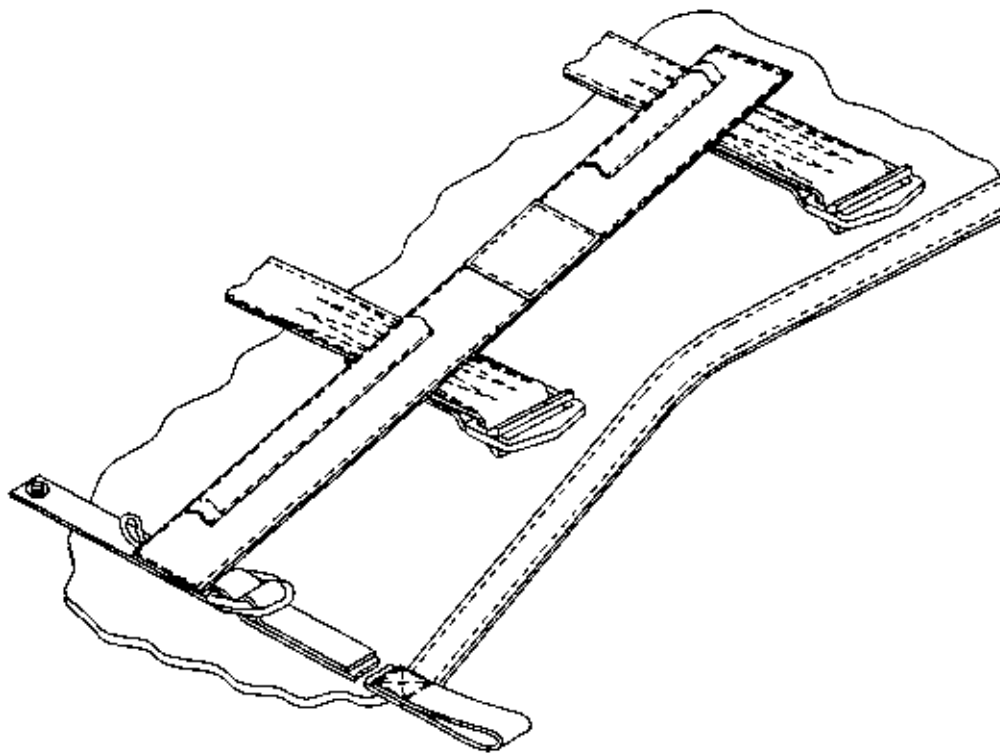

10. Cable Guide Assembly. Replace a damaged cable guide as follows:
- Cut stitching **(1)** that secures the cable guide **(2)** to the pack **(3)**.
 - Cut an appropriate piece of Type II nylon webbing equal in size to the piece being replaced.
 - Stitch as in original using size FF thread, 6 to 9 stitches per inch and a MD sewing machine.
11. Pile Fastener. Replace any damaged or missing pile fastener **(4)** on the pack **(3)** as follows:
- Cut stitching **(5)** that secures the pile fastener to the pack.
 - Cut an appropriate piece of pile tape, as required, equal in size to the piece being replaced.
 - Stitch to pack as in original using size FF thread, 6 to 9 stitches per inch and a MD sewing machine.

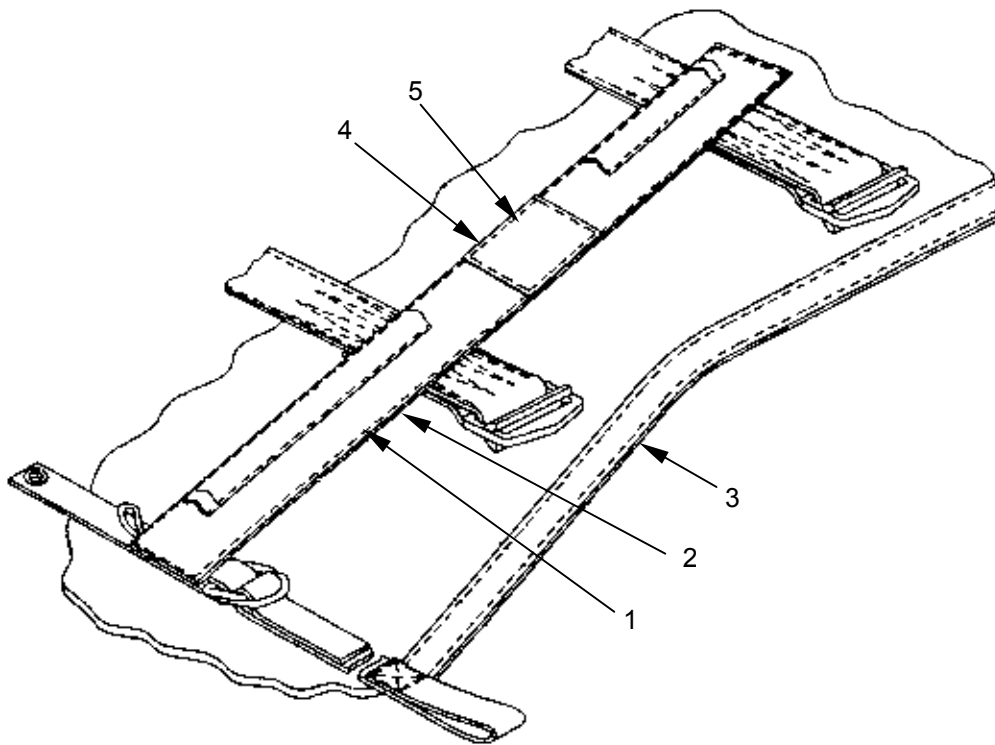

12. Quick-Release Assembly and Snap Shackle. Replace damaged snap shackle, 1-inch webbing, single pull handle, coated wire and swaging as follows:

a. Shackle and loop assembly. Replace any damaged part of the shackle and loop assembly (1) as follows:

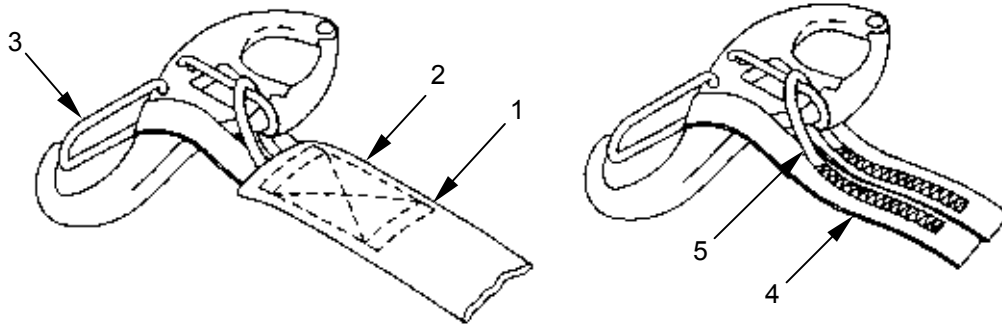

(1) Cut stitching from webbing (2) and remove snap shackle (3), 1/2-inch tape (4) and Type III nylon loop (5). Discard and replace damaged components. Replace 1/2-inch tape with 7-inch length of Type IV 1/2-inch nylon tape. Replace nylon loop with 7-inch length of Type III nylon cord. Sew as shown using size 3 thread, 5 to 8 stitches per inch and a HD sewing machine.

(2) Sew assembly to webbing with box X stitch as shown, using size 3 thread, 5 to 8 stitches per inch and a HD sewing machine.

b. 1-inch Webbing. Replace damaged webbing (1) by shackle and loop assembly as in a 1 above. Set assembly aside.

(1) Cut stitching from pile fastener (6) and 1-inch webbing (1) on the release handle (7) and remove and discard webbing. Replace with 12 1/2-inch length of nylon webbing.

(2) Assemble webbing (1), snap shackle (3), 1/2-inch tape (4), and Type III nylon loop (5) on release handle (7) as shown and using size 3 thread, 5 to 8 stitches per inch and a HD sewing machine.

c. Release Handle, coated wire and swaging.

(1) Cut stitching on pile fastener (6) and webbing (1) on the release handle (7) and remove release handle. Set aside pile fastener and webbing.

(2) Cut stitching on release handle (7) enough to remove coated wire (8) as shown. Discard damaged components.

(3) Replace damaged release handle (7) with an 18-1/2-inch length of Type VIII woven nylon webbing, yellow. Replace damaged wire (8) and swaging (9) with a 25 3/4-inch length of Type IIB, 5/32-inch O.D. coated wire rope and 5/32-inch swaging sleeve. Swage swaging sleeve as shown.

- d. Assemble components as in original construction. Sew using size 3 thread, 5 to 8 stitches per inch and a HD sewing machine

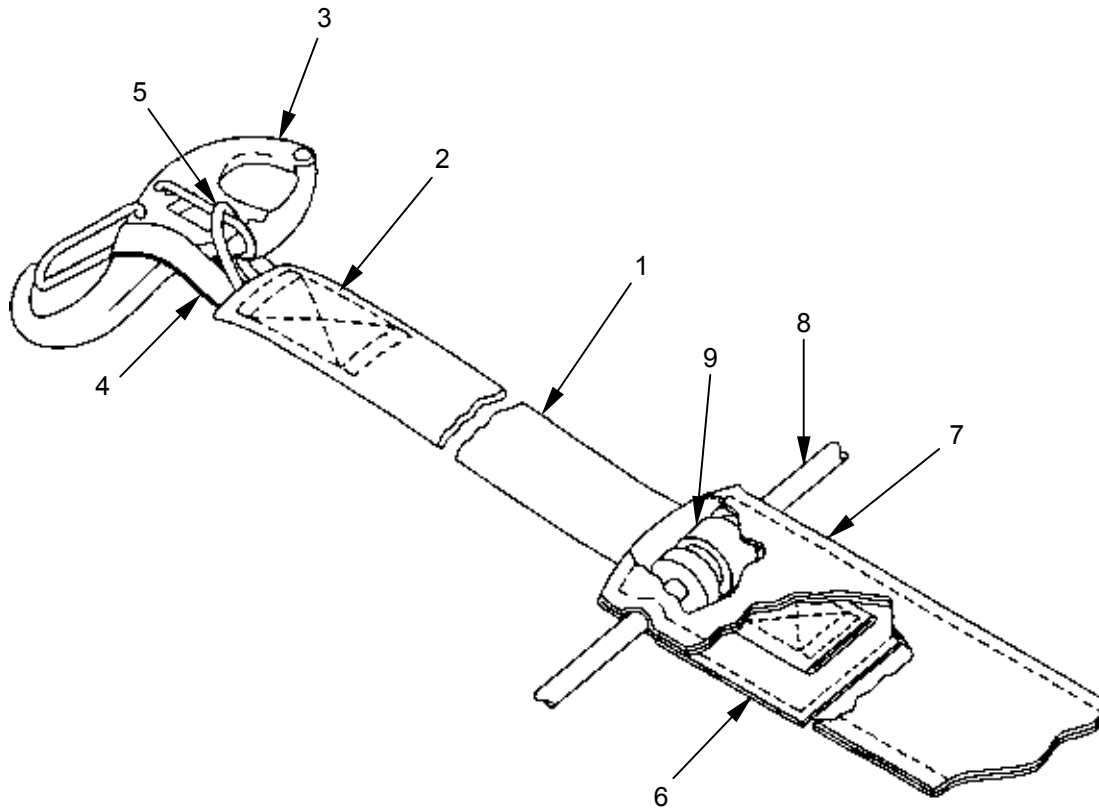

13. Extension Sling. Replace damaged extension sling, D-Ring, and 4-inch length of Type X nylon webbing as follows:

a. D-Ring and 4-inch nylon webbing. Replace damaged D-Ring (1) and 4-inch nylon webbing (2) as follows:

(1) Cut stitching from hook fastener (3) on D-Ring end of extension sling (4), remove and set aside fastener. Cut stitching (5) that supports D-Ring (1) and 4 inch nylon webbing (2) and remove D-Ring and webbing. Replace D-Ring (1) with a serviceable item. Replace 4-inch webbing with a 4-inch length of Type X woven nylon webbing.

(2) Sew D-Ring and hook fastener to extension sling as shown using size 3 thread, 5 to 8 stitches per inch and a HD sewing machine.

b. Extension sling (6) and retaining strap (7). Replace damaged extension sling and retaining strap as follows:

(1) Cut extension sling (6) from pack body (8).

(2) Follow step a) above for replacing D-Ring and 4-inch webbing except discard damaged extension sling (6) and replace with 78-inch length of 1-inch woven nylon webbing. Replace 3 1/2-inch webbing retainer (7) with a 3 1/2-inch length of Type II woven nylon webbing.

(3) Sew sling as shown and as in a) 2 above.

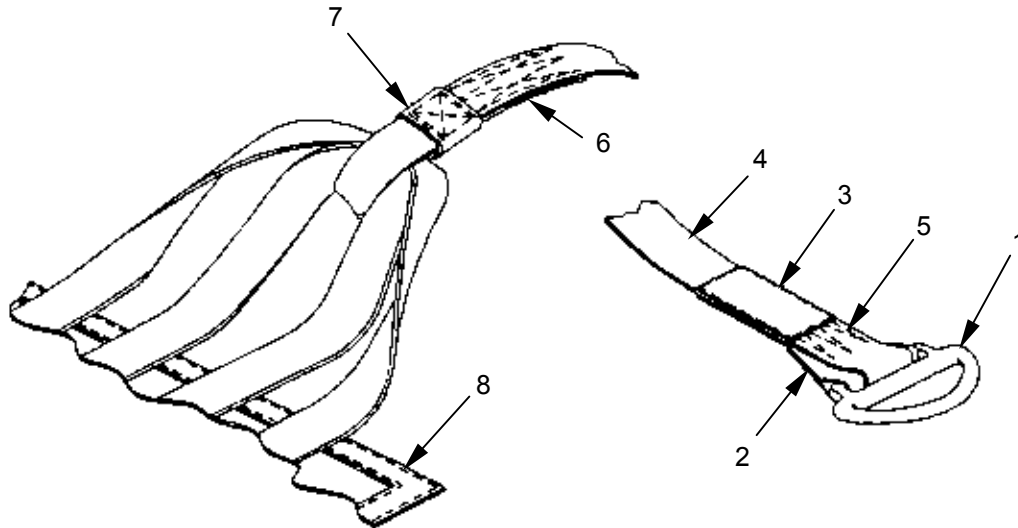

END OF WORK PACKAGE

ANCILLARY EQUIPMENT FOR PERSONNEL PARACHUTE SYSTEM

RELEASE ASSEMBLY
INSPECT, REPAIR, REPLACE

INITIAL SETUP:

Tools

Knife (WP 0034 00, Table 2, Item 6)
Shears (WP 0034 00, Table 2, Item 20)
Sewing Machine, Darning (WP 0034 00, Table 2, Item 15)
Sewing Machine MD (WP 0034 00, Table 2, Item 18)

Personnel Required

92R(10) Parachute Rigger

Materials/Parts

Tape, textile (WP 0052 00, Table 1, Item 44)
Thread, Nylon, size E (WP 0052 00, Table 1, Item 50)
Thread, nylon, size FF (WP 0052 00, Table 1, Item 51)
Cord, fibrous nylon Type III (WP 0052 00, Table 1, Item 12)
Webbing, tubular, nylon, 1-inch (WP 0052 00, Table 1, Item 71)
Cord, nylon, Type III, red (WP 0052 00, Table 1, Item 11)

Equipment Condition

Release Assembly should be clean and dry.
Place the assembly on worktable.

INSPECT

Perform a before and after technical/rigger type inspection of the Release Assembly as outlined in WP 0008 00.

REPAIR

The webbing on the release assembly may be restitched or darned. Splicing is not authorized. Restitch loose, broken, or defective stitching according to original construction details using size FF thread, 6 to 9 stitches per inch and a MD sewing machine. Darn using size E thread and a DN machine.

REPLACE

Replacement of the webbing components on the release assembly is not authorized. If assembly webbing becomes unserviceable and cannot be repaired, remove and retain any serviceable hardware, and discard webbing. Replace any hardware item on an otherwise serviceable release assembly as follows:

1. Shackle. Replace a damaged snap shackle **(1)** by cutting the stitching **(2)** that secures the item to the 1-inch tubular nylon webbing **(3)**.
 - a. Cut nylon cord **(4)** and tape retainers **(5)** from damaged shackle. Cut nylon cord **(4)** and tape retainers **(5)** from damaged shackle.
 - b. Cut a 6-inch length of nylon tape retainer **(5)** and a 5-inch length of nylon cord retainer **(4)**.
 - c. Install retainers on new shackle **(1)** as shown. Sandwich retainer ends between 1-inch tubular nylon webbing **(3)** and stitch with a box X stitch **(2)** using size FF thread, 6 to 9 stitches per inch and a MD sewing machine.

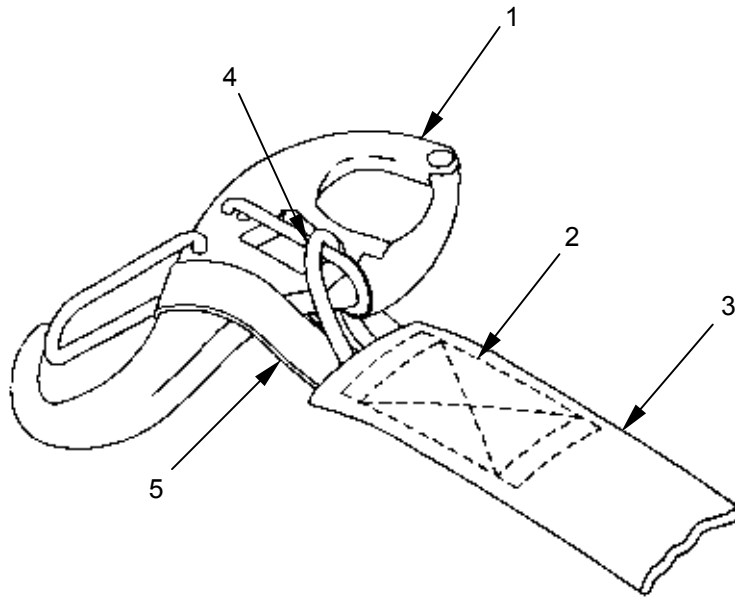

2. Snap Hook. Replace a damaged snap hook (1) by cutting the stitching (2) that secures the item to the 1-inch nylon tape (3).
 - a. Remove the damaged snap hook (1) and discard.
 - b. Thread 1-inch nylon tape (3), through serviceable snap hook (1) and fold back 1 3/8-inch.
 - c. Secure new snap hook (1) with two straight stitch formations (2) as shown using size FF thread, 6 to 9 stitches per inch and a MD sewing machine.

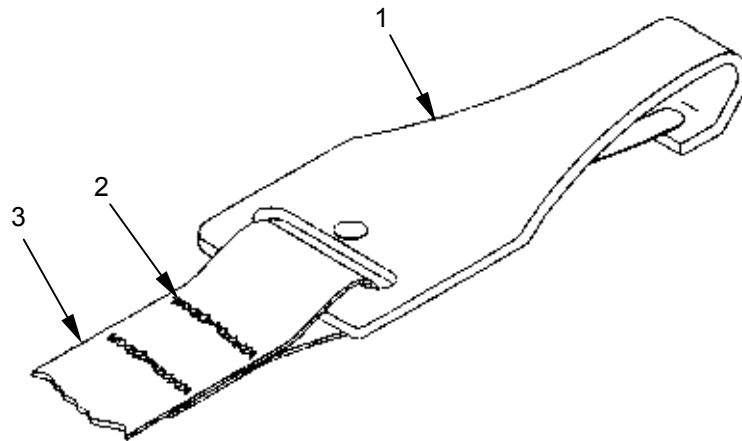

3. D-Ring. Replace a damaged D-Ring (1) by cutting the stitching (2) that secures the item to the 1-inch tubular nylon webbing (3).
 - a. Remove the damaged D-Ring(s) (1) and discard.
 - b. Thread 1-inch tubular nylon webbing (3) through new D-Ring(s) (1) and fold tubular nylon webbing (3) over red nylon cord (4) and release assembly strap (5).
 - c. Position tubular webbing (3) on release assembly strap (5) as in original construction and secure with a box X stitch (2) using size FF thread, 6 to 9 stitches per inch and a MD sewing machine.

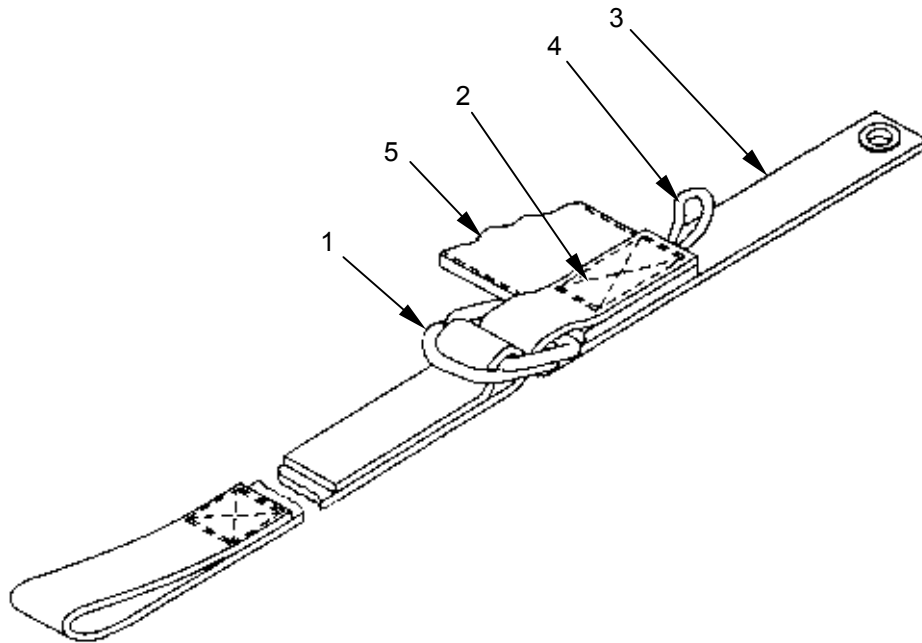

END OF WORK PACKAGE

UNIT MAINTENANCE

ANCILLARY EQUIPMENT FOR PERSONNEL PARACHUTE SYSTEM

CONTAINER, FRONT MOUNT
INSPECT, REPAIR, REPLACE

INITIAL SETUP:

Tools

Knife (WP 0034 00, Table 2, Item 6)
 Shears (WP 0034 00, Table 2, Item 20)
 Needle, Tacking (WP 0034 00, Table 2, Item 9)
 Pot, melting (WP 0034 00, Table 2, Item 10)
 Sewing Machine, Darning (WP 0034 00, Table 2, Item 15)
 Sewing Machine, MD (WP 0034 00, Table 2, Item 18)

Personnel Required

92R(10) Parachute Rigger

Materials/Parts

Cloth, duck, nylon (WP 0052 00, Table 1, Item 9)
 Cord, nylon, Type III, red (WP 0052 00, Table 1, Item 11)
 Felt, 1/4-inch thick (WP 0052 00, Table 1, Item 17)
 Tape, nylon, Type III (WP 0052 00, Table 1, Item 39)
 Thread, nylon, size E (WP 0052 00, Table 1, Item 50)
 Thread, nylon, size FF (WP 0052 00, Table 1, Item 51)
 Thread, nylon, size 3 (WP 0052 00, Table 1, Item 47)
 Wax, Paraffin, Type I, Technical (WP 0052 00, Table 1, Item 52)
 Beeswax, Technical, 1 lb cake (WP 0052 00, Table 1, Item 1)
 Webbing, nylon, type VII (WP 0052 00, Table 1, Item 64)

Equipment Condition

Container should be clean and dry. Place container on worktable.

INSPECT

Perform a before and after technical/rigger type inspection of the Front Mount Container as outlined in WP 0008 00.

REPAIR

The nylon duck material of the container and attached flap assemblies may be restitched, darned, and patched. The felt lining may be restitched and plugged. When making any of these repairs, remove stitching as necessary to gain access to the damaged area. After repairs have been made, replace any stitching that has been removed, as in original construction or as specified in each procedure. Repair duck and felt fabrics by restitching, darning and patching as described below.

1. Restitching. Restitch the container fabric directly over old stitching using size FF thread, 6 to 9 stitches per inch, and a MD sewing machine. Lock stitching at least $\frac{1}{2}$ -inch.
2. Darning. Darn a hole or tear in the container fabric that does not exceed 1-inch in length or diameter using size E thread and a darning machine. There is no limit to darns that may be applied, provided they do not weaken or reduce the original strength of the fabric more than 10%. If damage is in the lined portion of the container body and only the cotton duck is damaged, darn through duck and felt. If felt is also damaged, remove damaged area before darning duck fabric. Then plug felt as in 3. c) below.
3. Patching. There is no limit to the number of times the container body may be patched. Patch a hole or tear that exceeds 1-inch in length or diameter following procedures in (1) or (2) below. Use nylon duck cloth according to original construction for patching outside, and $\frac{1}{4}$ -inch thick felt for plugging inside lining. Use a MD sewing machine, size FF thread, and 6 to 9 stitches per inch.
 - a. To patch a lined portion of the container when the felt is not damaged, cut nylon duck patch 2-inches beyond circumference of damaged portion. Turn under edges of patch $\frac{1}{2}$ -inch and center patch over damaged area. Sew patch to container with a double row of stitching as shown.

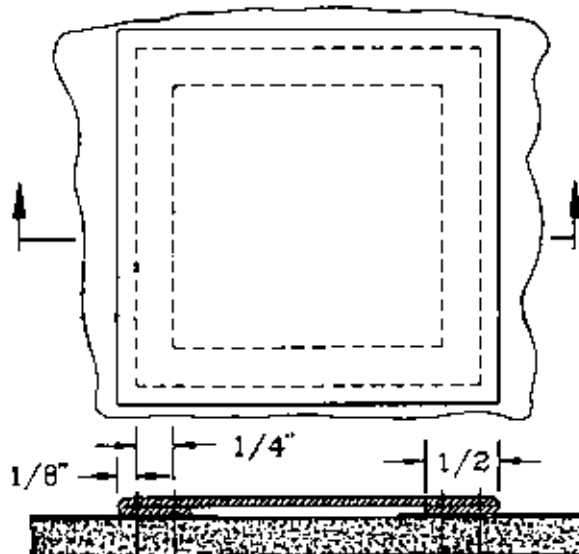

- b. To patch a lined portion of the container when the felt is damaged, remove the damaged felt as described in c below. Cut a piece of felt the same size as the piece removed, and position felt plug and cotton duck patch (with edges turned under 1/2-inch) over damaged area. Sew a single box X stitch formation as shown.

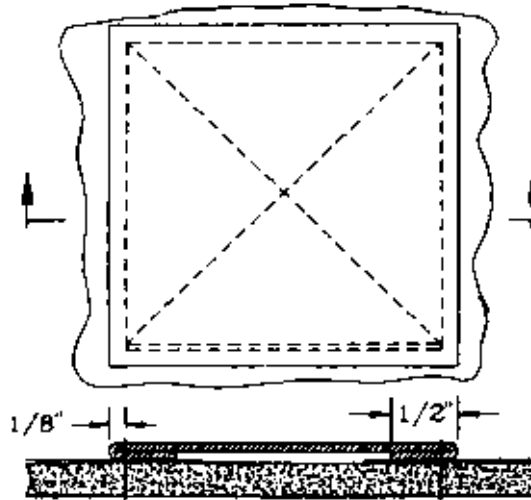

- c. To plug the felt lining of container, mark a rectangle around the damaged area. Remove the damaged felt while being careful not to damage the nylon duck material. Cut a piece of felt the size of the piece removed. Position felt plug into area cleared and sew as shown.

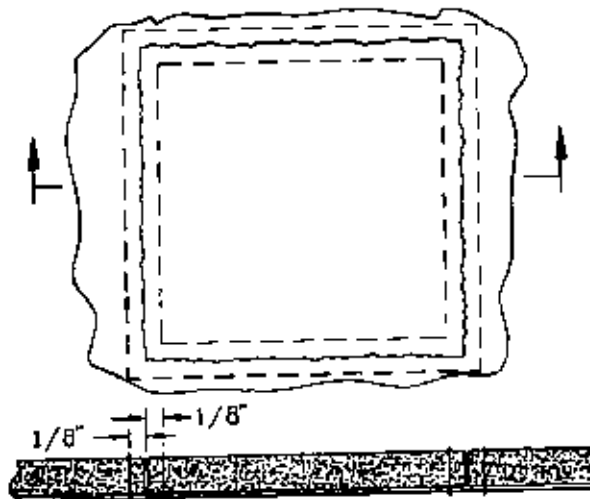

- d. If damage is in an area that cannot be sewed by machine, tack felt plug securely to nylon duck as shown using doubled and waxed size 3 nylon thread. Secure thread ends with suitable knot.

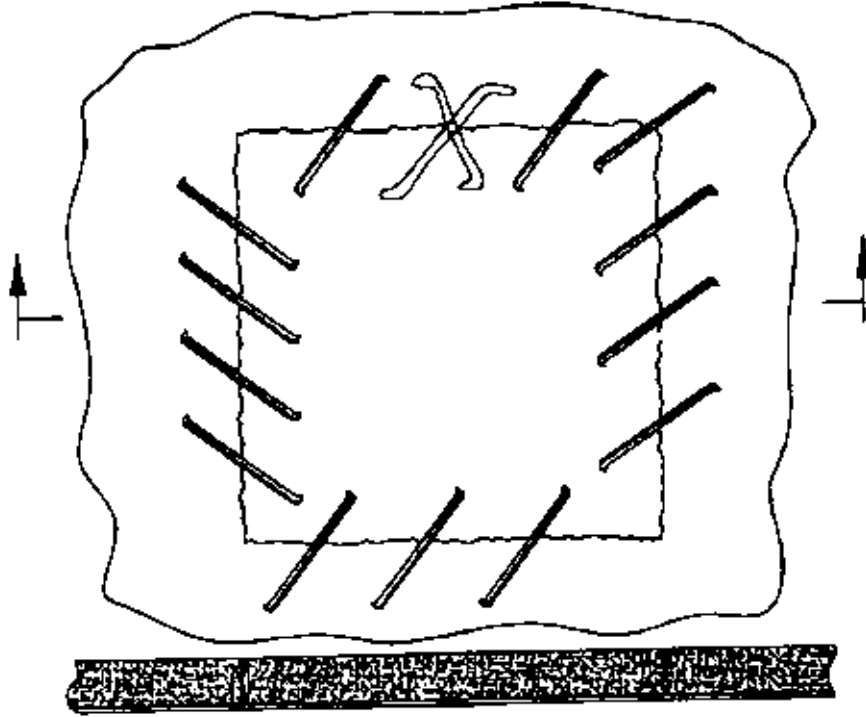

4. Repair of Binding Tape. Overlap the binding tape, extending the new tape at least 1-inch beyond the damaged tape. Stitch tape with two rows of stitching $\frac{1}{8}$ and $\frac{1}{4}$ -inches from edge of tape as in original construction using size FF thread, 6 to 9 stitches per inch and a MD sewing machine.
5. Repairing Webbing. The webbing on the pack may be restitched or darned. Restitch loose, broken, or defective stitching according to original construction details using size FF thread, 6 to 9 stitches per inch and a MD sewing machine. Darn using size E thread and a darning machine.

REPLACE

Replacing Webbing. All webbing in **(1)** through **(11)** below may be replaced. Replacement will be accomplished in accordance with the original construction and as prescribed herein. Seal all cut ends of webbing before assembling webbing on pack.

NOTE

Splicing and darning of the attaching strap assembly is not authorized.

1. Horizontal Restraint Assembly. To replace this assembly **(1)** proceed as follows:
 - a. Cut the stitching **(2)** that secures the damaged assembly to the container body **(3)** and vertical restraint assembly **(4)**.
 - b. Cut off any serviceable hardware items and closing assemblies **(5)** and set aside.
 - c. Fabricate new assembly **(1)** as described in WP 0053 00, using salvaged, serviceable hardware items **(5)** and closing assemblies removed as applicable.
 - d. Place new horizontal restraint assembly **(1)** onto container **(3)** as shown and sew as in original construction using size 3 thread, 5 to 8 stitches per inch and a MD sewing machine.

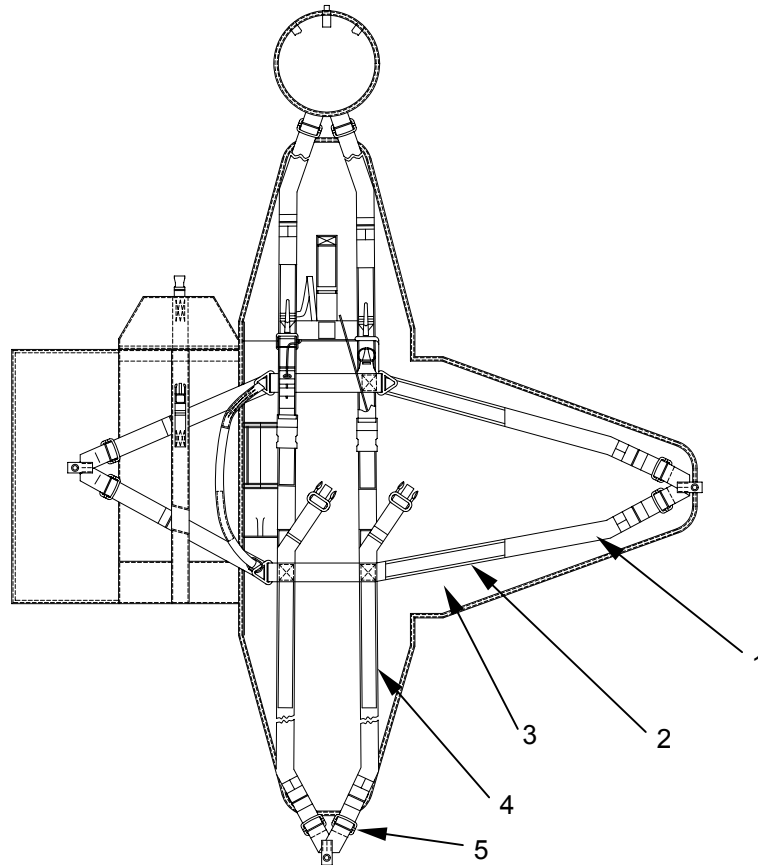

0027 00-5

2. Vertical Restraint Assembly. To replace this assembly (1) proceed as follows:
 - a. Cut the stitching (2) that secures the damaged assembly to the container body (3) horizontal restraint assembly (4) and the release assembly (5).
 - b. Remove serviceable hardware items (6) the flap assemblies (7) and the closing assembly (8).
 - c. Fabricate new vertical restraint assembly (1) as described in WP 0053 00, using salvaged, serviceable hardware items (6) and closing assembly (8) removed, as applicable.
 - d. Place new vertical restraint assembly (1) onto container (3) as shown and sew as in original construction using size 3 thread, 5 to 8 stitches per inch and a MD sewing machine.

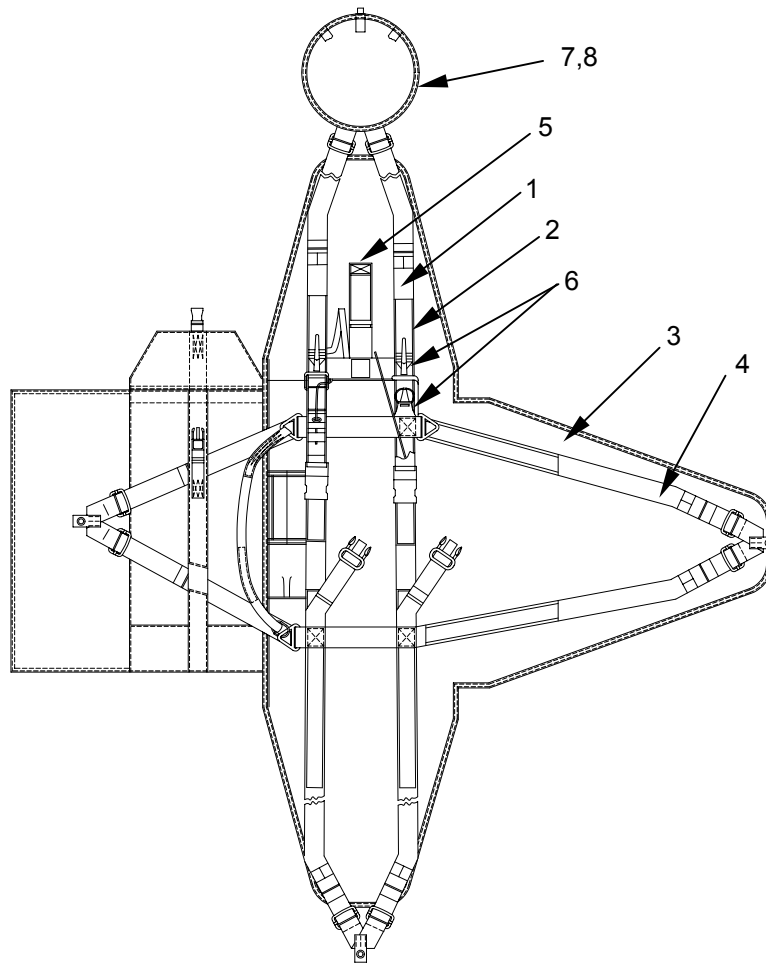

3. Closing Flap Assembly. To replace this assembly (1) proceed as follows:
 - a. Remove the reversible quick fit adapters (2) on the restraining loop assembly (3) from the vertical restraint assembly (4). Remove the flap assembly (1) from the restraining loop assembly (3) by cutting the stitching (5) holding these assemblies together.
 - b. If the restraining loop assembly (3) is also being replaced, remove serviceable quick fit adapters (2) and set aside.
 - c. Fabricate new closing flap assembly (1) and restraining loop assembly (3), if required, as described in WP 0053 00.
 - d. Attach quick fit adapters (2) on restraining loop assembly (3) with new closing flap assembly (1) onto vertical restraint assembly (4).

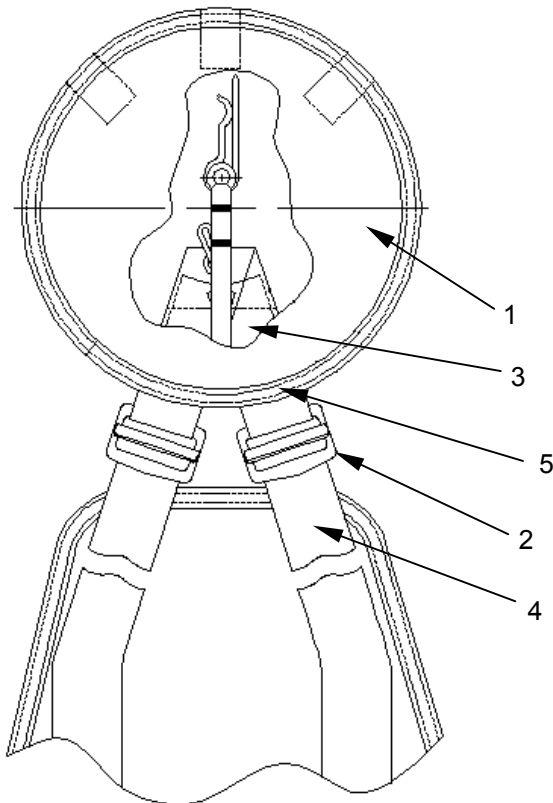

4. Pocket Assembly, Lowering Line, Closure Flap Assembly, and Inner Flap Assembly. To replace these assemblies proceed as follows:
 - a. Cut the stitching that secures the damaged pocket (1), closure (2) and inner flap assembly (3) to the container body (4), vertical restraint assembly (5) and the side container assembly (6).
 - b. Remove nylon tape loop (7) from container body if damaged.
 - c. Fabricate new pocket (1), closure flap (2), and inner flap (3) as described in WP 0053 00.
 - d. Place new pocket (1), closure flap (2), and inner flap (3) onto container body (4) as shown and sew using size 3 thread, 5 to 8 stitches per inch and a MD sewing machine.

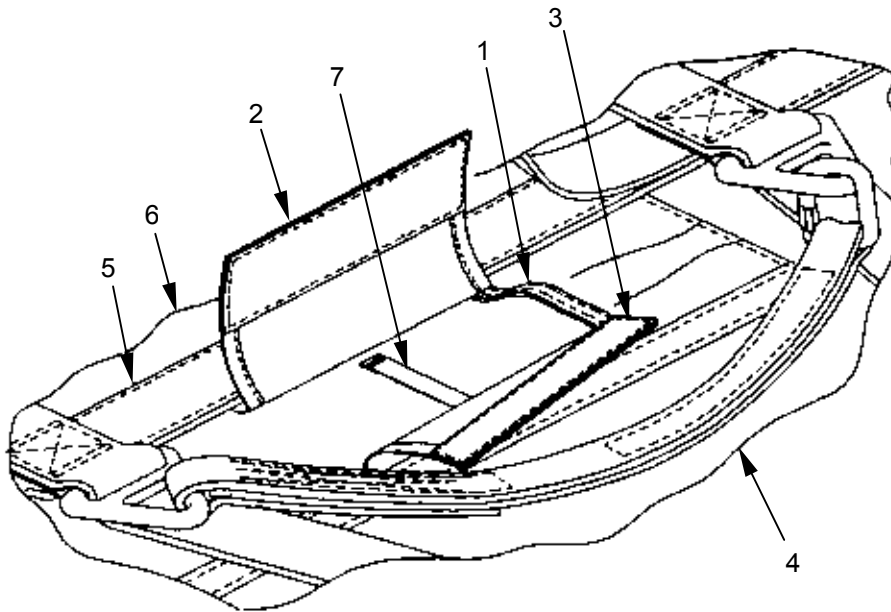

5. Container Assembly, Side. To replace this assembly proceed as follows:
 - a. Remove the horizontal restraint assembly straps (1) from the side container (2).
 - b. Cut the stitching that secures the damaged container (2), to the container body (3).
 - c. Remove serviceable hardware items (6) and set aside.
 - d. Fabricate new container (2) as described in WP 0053 00.
 - e. Place new container (2), onto container body (3) as shown and sew using size 3 thread, 5 to 8 stitches per inch and a MD sewing machine.
 - f. Reinstall the horizontal restraint assembly straps (1) onto the side container (2).

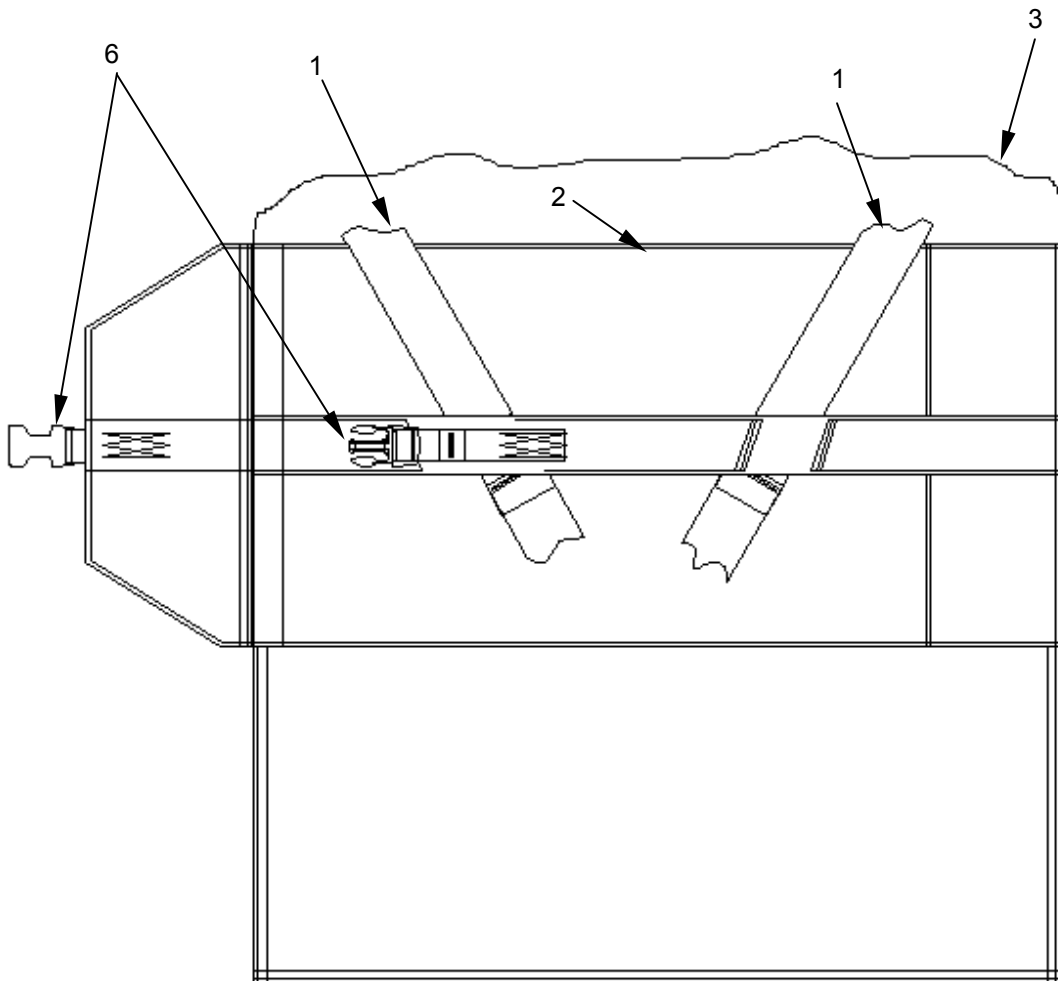

6. Kit, Bag Assembly, Internal. To replace this assembly proceed as follows:
 - a. Cut the stitching (3) that secures the damaged bag (1), to the container body (2).
 - b. Fabricate new bag assembly (1) as described in WP 0053 00.
 - c. Sew new bag assembly (1) to container (2) using size 3 thread, 5 to 8 stitches per inch and a MD sewing machine.

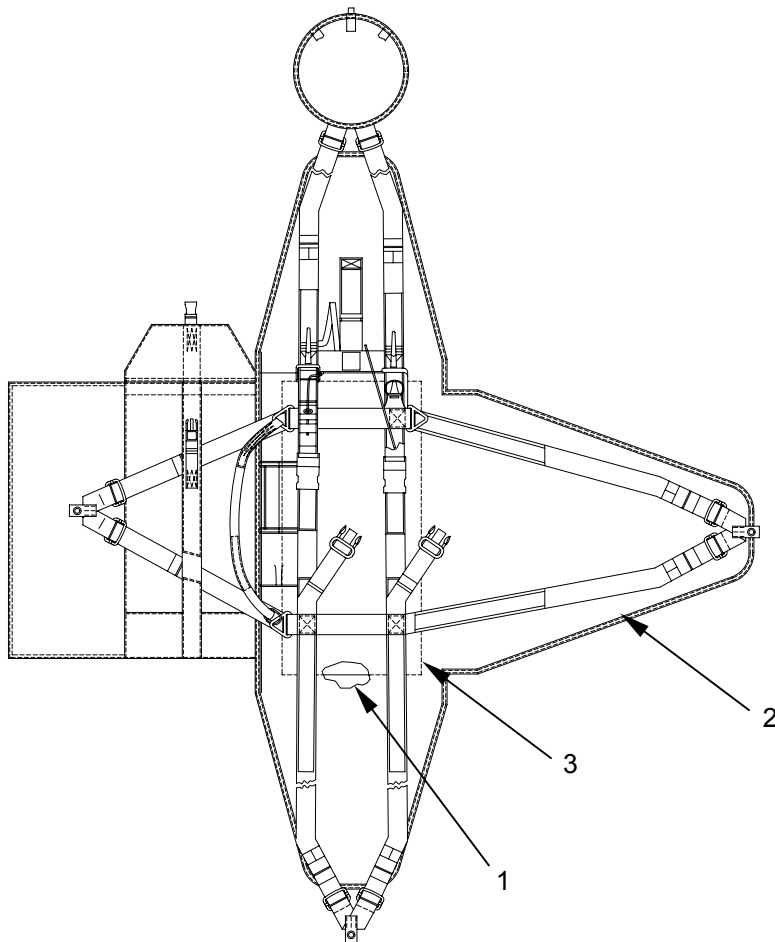

7. Bridle Assembly. To replace this assembly proceed as follows:
 - a. Cut the damaged bridle assembly (1), from the triangle link (2) holding it to the horizontal restraint assembly (3). If link (2) is to be replaced, cut the stitching (4) holding the link chape (5) to the horizontal (3) and vertical restraint assemblies (6).
 - b. Remove rapid connector link (7) from bridle assembly (1).
 - c. Fabricate new bridle assembly (1) as described in WP 0053 00.
 - d. Attach new bridle assembly (1) by threading triangular link (2) to chape and restitching chape with a box X stitch to the vertical restraint assembly using size 3 thread, 5 to 8 stitches per inch and a MD sewing machine. Connect the rapid connector link (7) to the other triangular link.

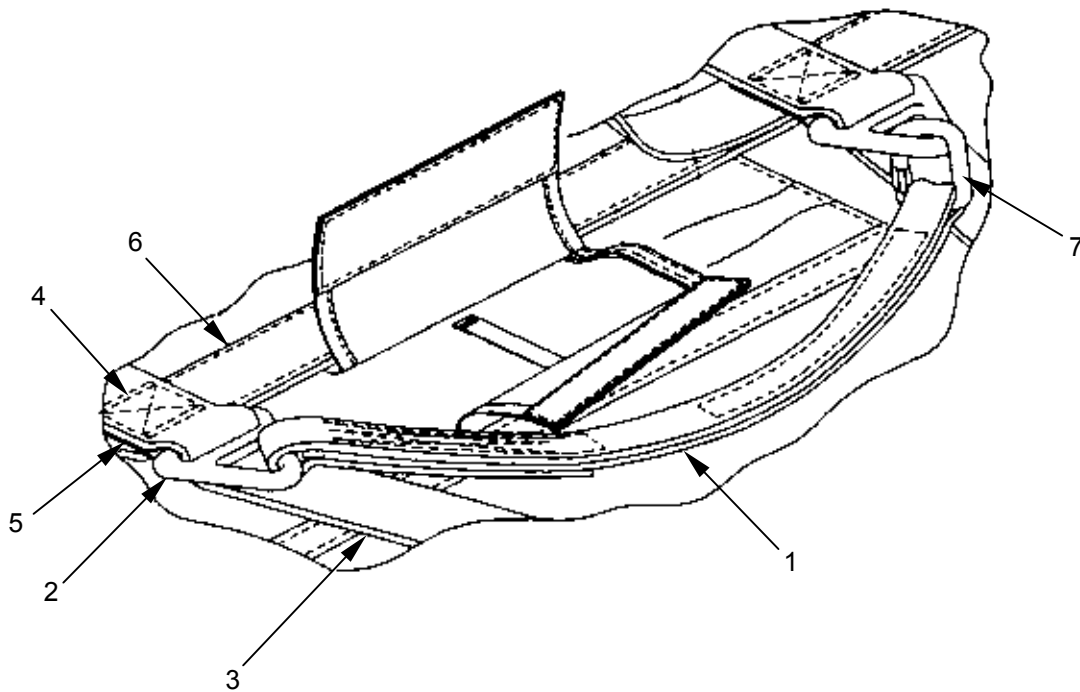

8. Attaching Strap Assembly. To replace this assembly proceed as follows:
- Remove serviceable snap hook (1) and ring (2) by cutting the webbing (3), and set aside.
 - Fabricate new attaching strap assembly (3) as described in WP 0053 00, using serviceable hardware items salvaged as applicable.

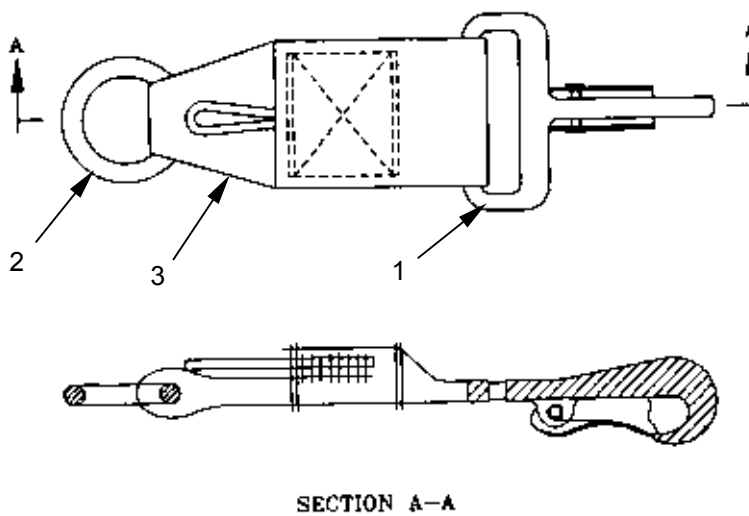

9. Leg strap Assembly. To replace this assembly proceed as follows:
 - a. Remove serviceable plastic side release (1) by cutting the webbing (2), and set aside.
 - b. Cut webbing and remove damaged part, or if the entire strap is to be replaced, cut stitching (3) that holds the strap to the container (4).

NOTE

Splice a leg strap using size 5 thread, 4-6 stitches per inch, and a MD sewing machine only if at least 4-inches of free running, serviceable end from the attachment point on the container is available to facilitate overlap.

- c. Cut an appropriate length of Type VII nylon webbing (2) to splice or replace the leg strap entirely.
- d. Place plastic side release (1) onto strap as on original construction using new, or serviceable hardware items salvaged as applicable.
- e. Turn running end under 1-inch twice and secure with box stitch using size FF thread, 6 to 9 stitches per inch and a MD sewing machine.

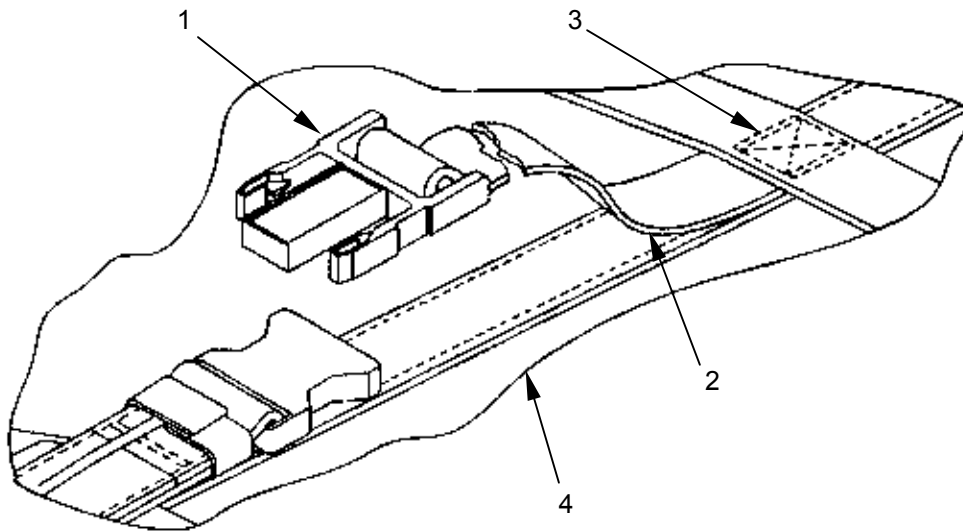

10. Leg Strap Release Assembly. To replace this assembly proceed as follows:

- a. Remove serviceable release (1) by cutting the webbing (2), and set aside.
- b. Fabricate new leg strap release assembly as described in WP 0053 00, using serviceable hardware items salvaged as applicable.

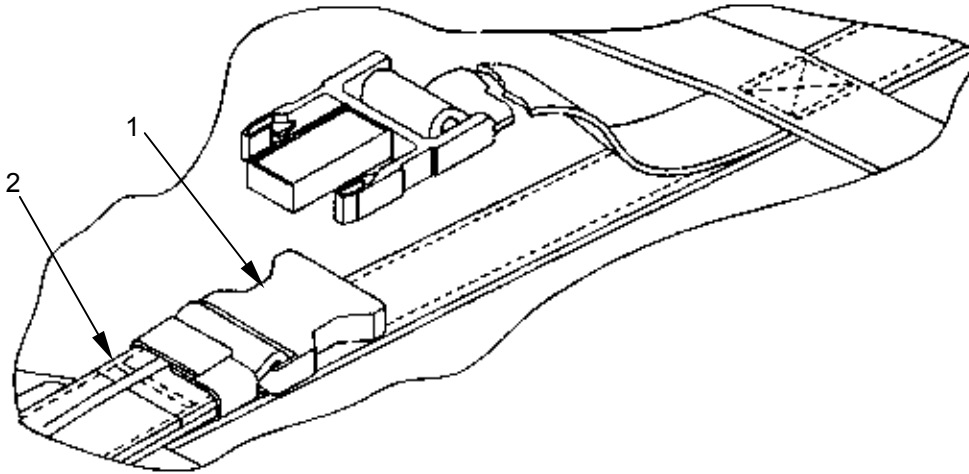

11. Release Assembly Handle. To replace this assembly proceed as follows:

- a. Remove stitching (2) that secures lanyard (1) to the container (4). Discard a damaged handle assembly (3).
- b. Fabricate a new release assembly handle (3) as described in WP 0053 00.
- c. Sew lanyard (1) to container as in original construction using size 3 thread, 5 to 8 stitches per inch and a MD sewing machine.

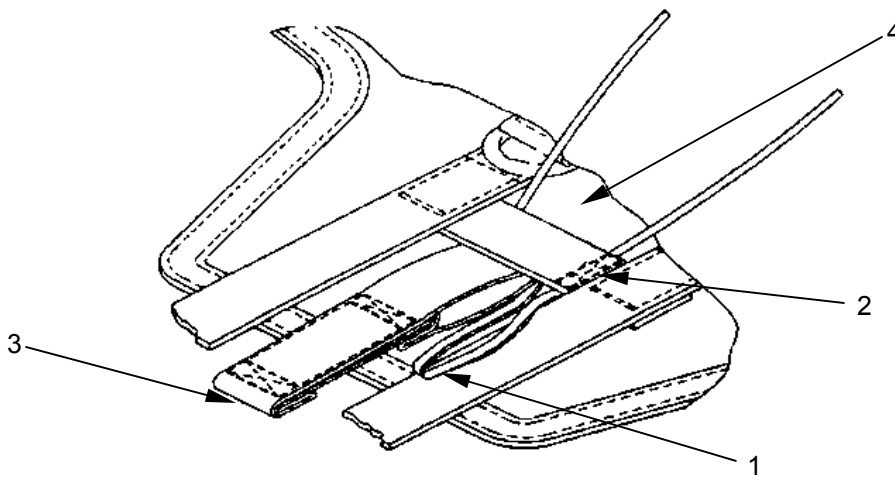

END OF WORK PACKAGE

UNIT MAINTENANCE

ANCILLARY EQUIPMENT FOR PERSONNEL PARACHUTE SYSTEM

CONTAINER, SIDE MOUNT
INSPECT, REPAIR, REPLACE**INITIAL SETUP:****Tools**

Knife (WP 0034 00, Table 2, Item 6)
 Shears (WP 0034 00, Table 2, Item 20)
 Needle, Tacking (WP 0034 00, Table 2, Item 9)
 Pot, melting (WP 0034 00, Table 2, Item 10)
 Sewing Machine, Darning (WP 0034 00, Table 2, Item 15)
 Sewing Machine, MD (WP 0034 00, Table 2, Item 18)
 Sewing Machine, HD (WP 0034 00, Table 2, Item 16)

Personnel Required

92R(10) Parachute Rigger

Materials/Parts

Thread, nylon, size E (WP 0052 00, Table 1, Item 50)
 Thread, nylon, size 3 (WP 0052 00, Table 1, Item 47)
 Thread, nylon, size 5 (WP 0052 00, Table 1, Item 48)
 Thread, nylon, size FF (WP 0052 00, Table 1, Item 51)
 Webbing, nylon, Type VIII (WP 0052 00, Table 1, Item 61)
 Webbing, nylon, Type VII (WP 0052 00, Table 1, Item 64)
 Tape, nylon, Type III (WP 0052 00, Table 1, Item 39)
 Wax, Paraffin, Type I, Technical (WP 0052 00, Table 1, Item 52)
 Beeswax, Technical, 1-lb cake (WP 0052 00, Table 1, Item 1)

Equipment Condition

Container should be clean and dry. Place container on worktable.

INSPECT

Perform a before and after technical/rigger type inspection of the Side Mount Container as outlined in WP 0008 00.

REPAIR

The nylon duck material of the container body may be restitched, darned, and patched. The polyester felt material may be restitched and plugged as described below.

1. Restitching. Restitch the container fabric directly over old stitching using stitching specifications outlined in the appropriate repair procedures. Lock stitching at least $\frac{1}{2}$ -inch.

2. Darning. Darn a hole or tear in the container fabric that does not exceed 1-inch in length or diameter using size E thread and a darning machine. There is no limit to darns that may be applied, provided they do not weaken or reduce the original strength of the fabric more than 10%. If damage is in the lined portion of the container body and only the cotton duck is damaged, darn through duck and felt. If felt is also damaged, remove damaged area before darning duck fabric. Then plug felt as in 3. c) below.
3. Patching. There is no limit to the number of times the container body may be patched. Patch a hole or tear that exceeds 1-inch in length or diameter following procedures in a or b below. Use nylon duck cloth according to original construction for patching outside, and $\frac{1}{4}$ -inch thick felt for plugging inside lining. Use a HD sewing machine, size 3 thread, and 5 to 8 stitches per inch.
 - a. To patch a lined portion of the container when the felt is not damaged, cut nylon duck patch 2-inches beyond circumference of damaged portion. Turn under edges of patch $\frac{1}{2}$ -inch and center patch over damaged area. Sew patch to container with a double row of stitching as shown.

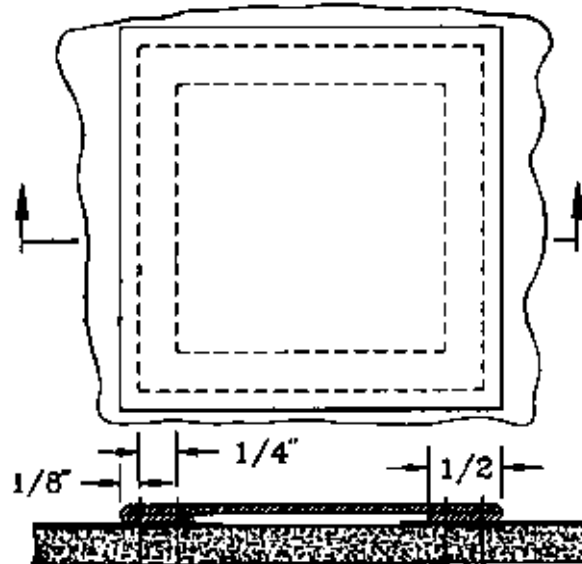

- b. To patch a lined portion of the container when the felt is damaged, remove the damaged felt as described in c) below. Cut a piece of felt the same size as the piece removed, and position felt plug and cotton duck patch (with edges turned under $\frac{1}{2}$ -inch) over damaged area. Sew a single box X stitch formation as shown.

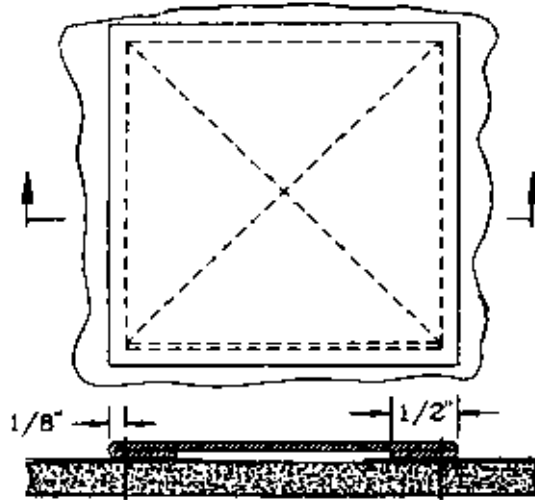

- c. To plug the felt lining of container, mark a rectangle around the damaged area. Remove the damaged felt while being careful not to damage the nylon duck material. Cut a piece of felt the size of the piece removed. Position felt plug into area cleared and sew as shown.

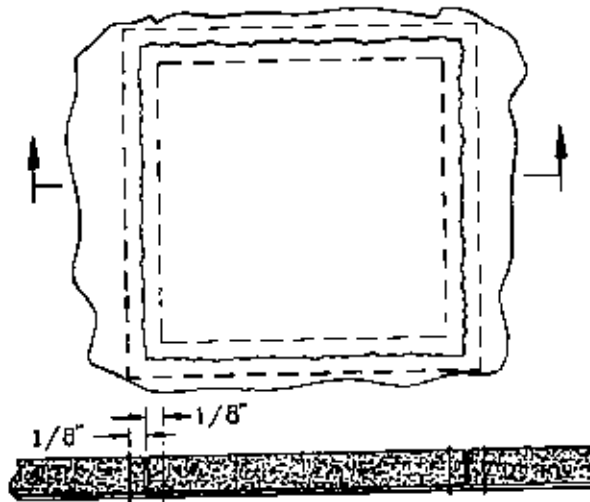

- d. If damage is in an area that cannot be sewed by machine, tack felt plug securely to nylon duck as shown using doubled and waxed size 3 nylon thread. Secure thread ends with suitable knot.

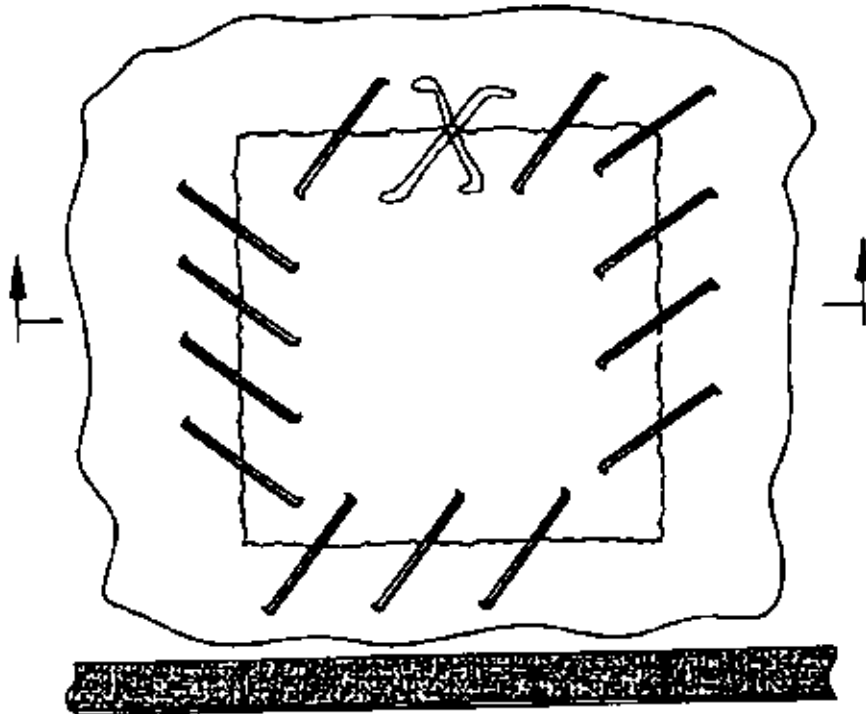

4. Repair of Binding Tape. Overlap the binding tape, extending the new tape at least 1-inch beyond the damaged tape. Stitch tape with two rows of stitching $\frac{1}{8}$ and $\frac{1}{4}$ -inches from edge of tape as in original construction using size FF thread, 6 to 9 stitches per inch and a HD sewing machine.
5. Repairing Webbing. The webbing on the pack may be restitched or darned (do not darn the attaching web). Restitch loose, broken, or defective stitching according to original construction details and as outlined in the appropriate repair procedures. Darn as in original construction.

REPLACE

Replacing Webbing. Webbing components in (1) through (8) below may be replaced. Replacement will be accomplished in accordance with the original construction and as prescribed herein. Sear all cut ends of webbing before assembling webbing on pack.

NOTE

Splicing and darning of the attaching strap assembly is not authorized.

1. Quick Release Link and V-Ring Chape Assembly. To replace this assembly proceed as follows:
 - a. Cut webbing to remove serviceable quick release link (1) and V-Ring (2).
 - b. Cut stitching (3) that holds chapes (4) and (5) to container.
 - c. Cut 25 1/2-inch length of Type VII nylon webbing and sear both ends.
 - d. Thread quick release link (1) onto one end of nylon webbing. Fold back end to form 4 1/2-inch chape (4). Place on container (6) as in original construction and sew as shown using size 5 thread, 4 to 6 stitches per inch and a HD sewing machine.
 - e. Thread V-Ring (2) onto other end of webbing. Fold end back to form 3 1/2-inch chape (5). Sew as V-Ring chape.

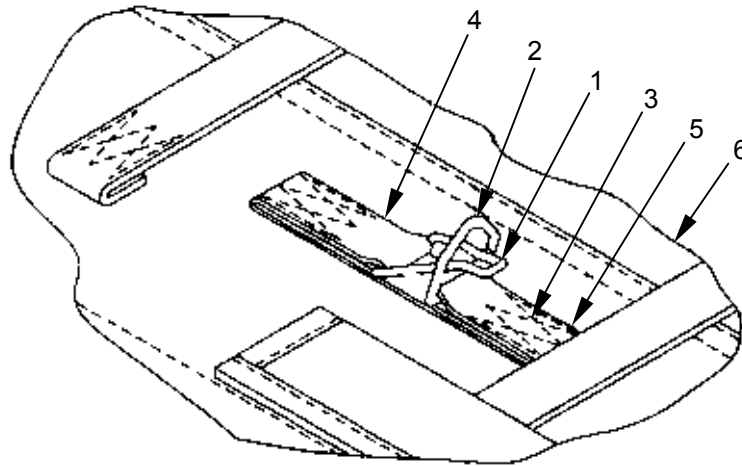

2. Flap Assembly V-Ring Harness. To replace the V-Ring (1) and webbing (2) proceed as follows:
 - a. Cut stitching (3) holding type VII webbing (2) to flap assembly (4). Remove V-Ring (1) from damaged webbing (2) and retain if serviceable.
 - b. Cut a 19-inch length of type VII nylon webbing (2) and sear both ends. Thread serviceable V-Ring (1) onto webbing (2). Fold as shown and place on flap assembly (4) as in original construction.
 - c. Sew as shown using size 5 thread, 4 to 6 stitches per inch and a HD sewing machine.

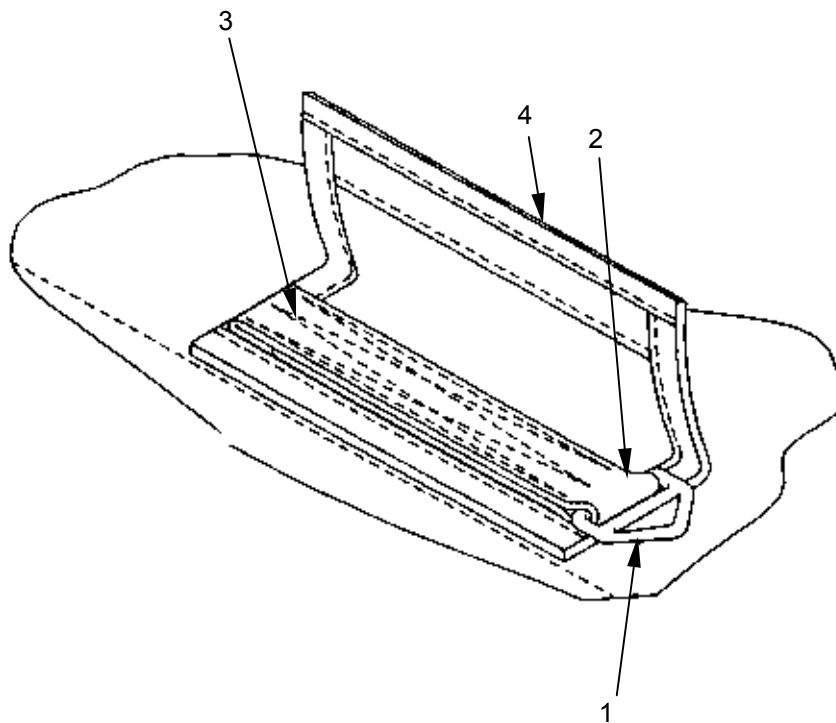

3. Carrying Handle Strap. To replace this strap **(1)** proceed as follows:
 - a. Cut stitching **(2)** that holds webbing **(3)** to container **(4)**.
 - b. Cut 8-inch length of Type VIII nylon webbing **(3)** and sear ends. Fold center 5-inches as shown **(5)** to form handle and place on container **(4)** as in original construction.
 - c. Sew handle strap to container with box X stitch using size 3 thread, 5 to 8 stitches per inch and a MD sewing machine.

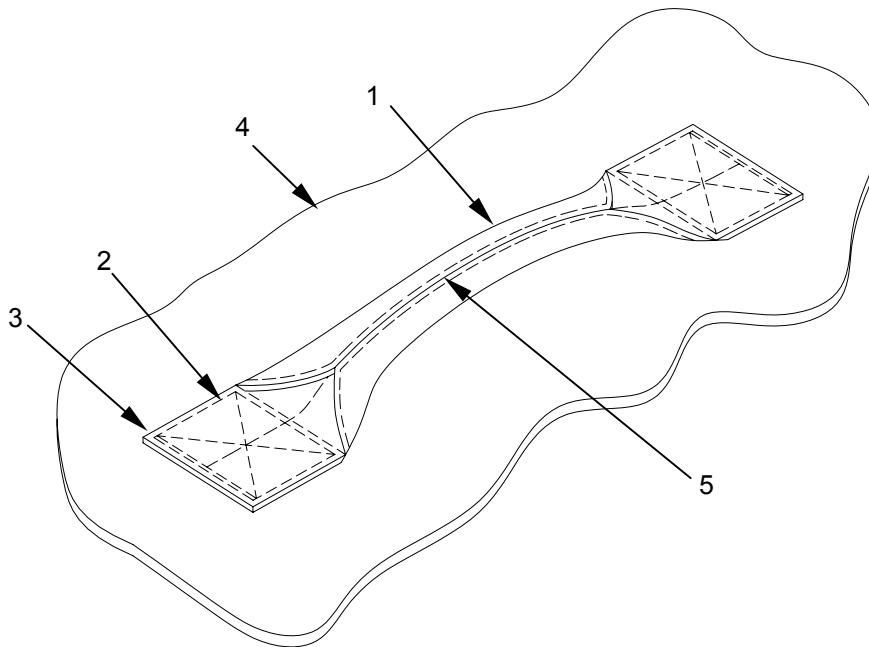

4. Side Securing Straps (Running Ends). To replace these straps **(1)** proceed as follows:
 - a. Cut strap **(1)** along stitching **(3)** that secures strap to container **(2)**.
 - b. Cut a length of Type VIII nylon webbing equal to the length removed.
 - c. Position replacement strap in original location on the container **(2)**. Stitch with 3 point WW pattern as shown using size FF thread, 6 to 9 stitches per inch and a MD sewing machine.

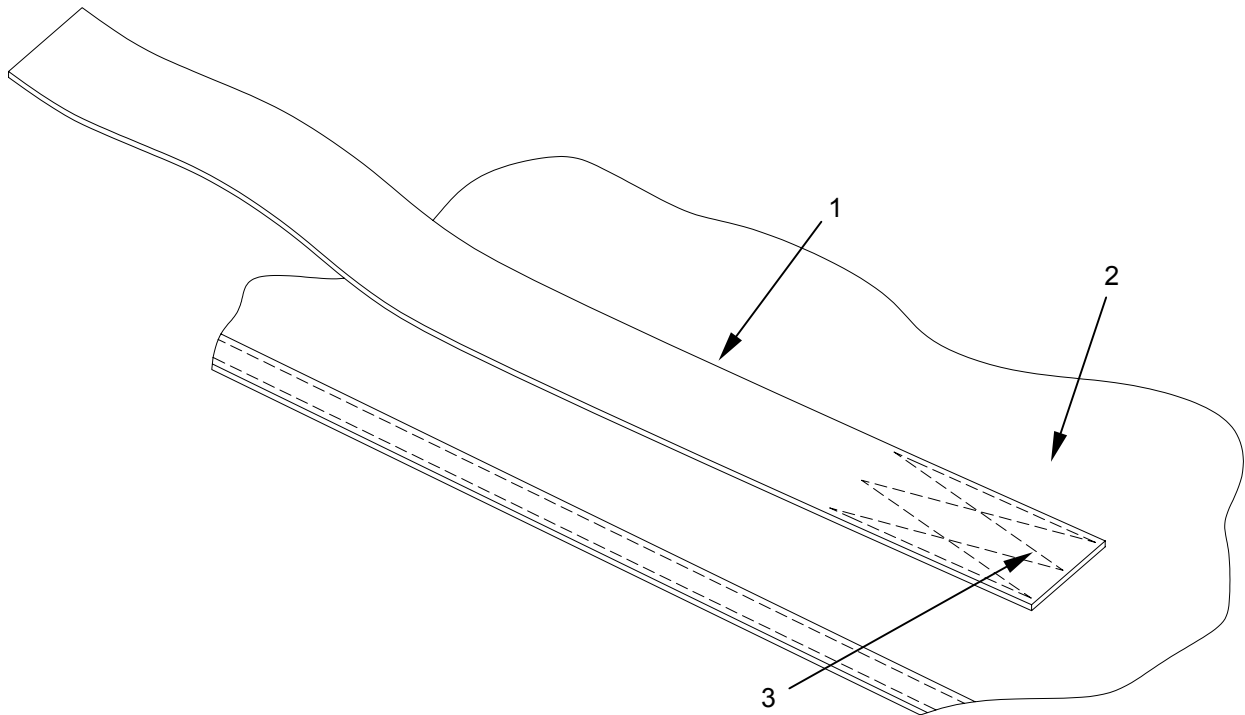

5. Side Securing Strap Quick Fit Adapters. To replace these straps proceed as follows:
 - a. Remove serviceable quick fit adapters **(1)** from webbing **(2)** by cutting the 3 point WW stitch pattern **(3)** and set aside.
 - b. Cut 7-inch length of Type VIII nylon webbing, and fold so ends meet 1-inch under **(4)**.
 - c. Place on container **(5)** as in original construction and stitch with 3 point WW pattern using size 3 thread, 5 to 8 stitches per inch and a MD sewing machine.

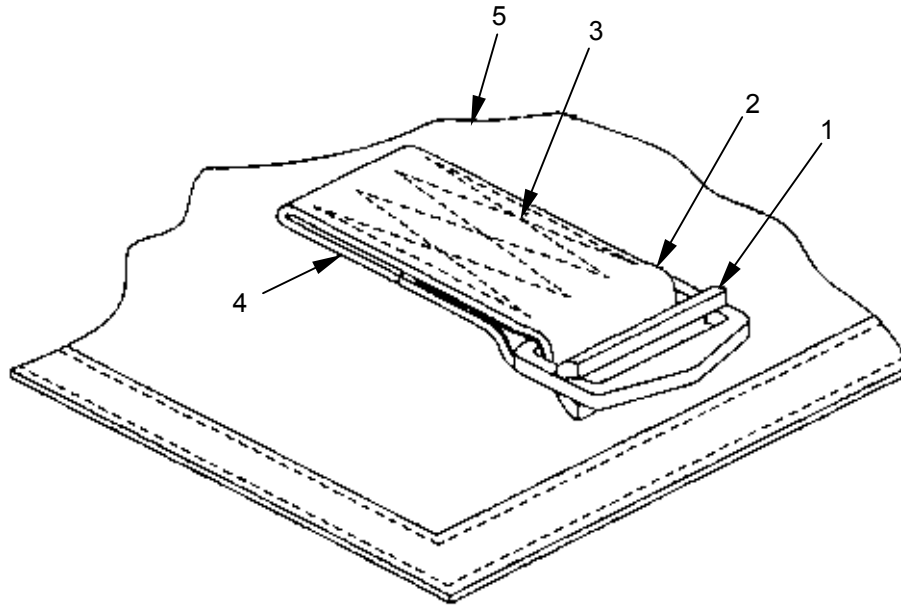

6. Upper Cap Assembly. To replace this assembly **(1)** proceed as follows:
 - a. Cut stitching **(2)** that secures cap assembly to container **(3)**.
 - b. Remove serviceable hardware **(4)** by cutting the webbing and set aside.
 - c. Fabricate a new cap assembly as described in WP 0053 00.
 - d. Place new cap assembly onto container as in original construction using size 3 thread, 5 to 8 stitches per inch and a HD sewing machine.

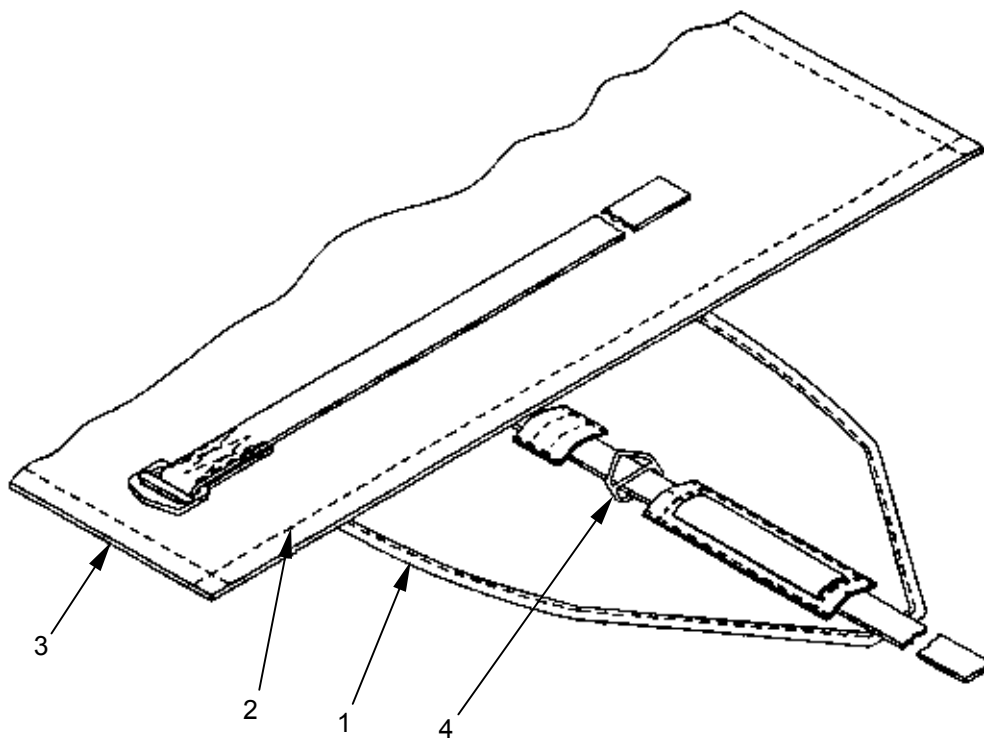

7. Lower Cap Assembly. To replace this assembly (1) proceed as follows:
 - a. Cut stitching (2) that secures cap assembly to container (3).
 - b. Remove serviceable hardware (4) by cutting the webbing and set aside.
 - c. Fabricate a new cap assembly as described in WP 0053 00.
 - d. Place new cap assembly onto container as in original construction using size 3 thread, 5 to 8 stitches per inch and a HD sewing machine.

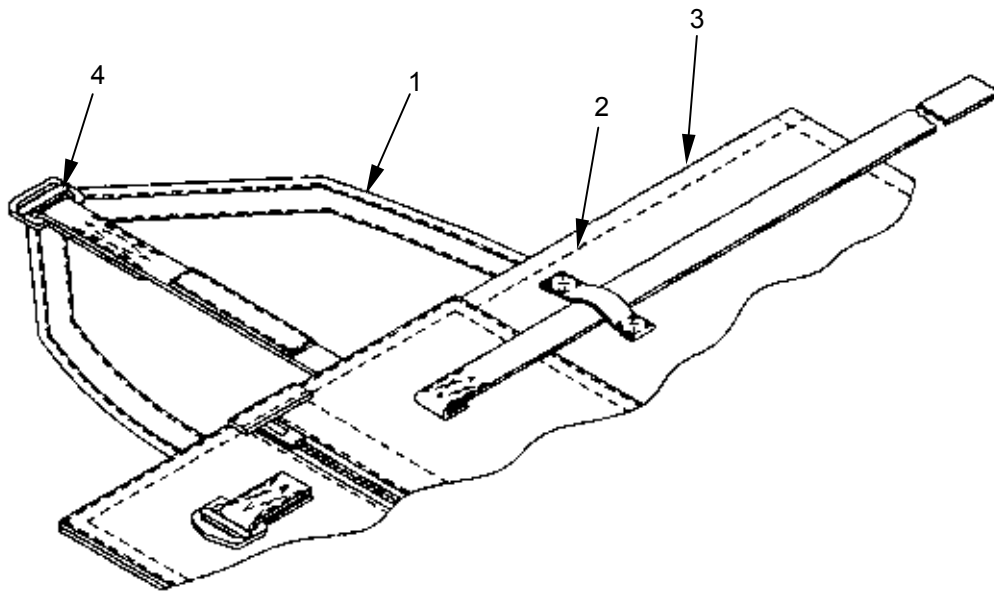

8. Bridle Assembly. To replace this assembly (1) proceed as follows:
 - a. Remove serviceable hardware (2) by cutting the webbing and setting the items aside.
 - b. Fabricate a new bridle assembly as described in WP 0053 00, using serviceable hardware salvaged, if appropriate.

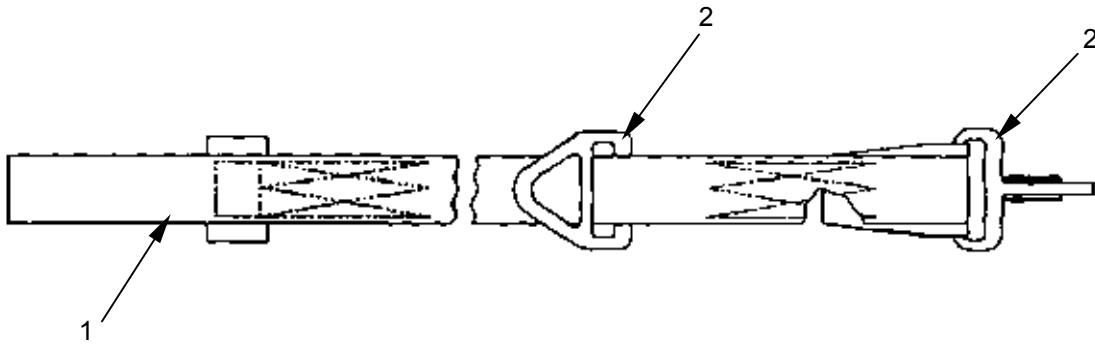

END OF WORK PACKAGE

UNIT MAINTENANCE

ANCILLARY EQUIPMENT FOR PERSONNEL PARACHUTE SYSTEM

PARACHUTE DROP BAG (PDB)
INSPECT, REPLACE, REPAIR**INITIAL SETUP:****Tools**

Knife (WP 0034 00, Table 2, Item 6)
 Sewing Machine, HD (WP 0034 00, Table 2, Item 16)
 Sewing Machine, LD (WP 0034 00, Table 2, Item 18)
 Sewing Machine, MD (WP 0034 00, Table 2, Item 18)
 Shears (WP 0034 00, Table 2, Item 20)

Personnel Required

92R(10) Parachute Rigger

Materials/Parts

Thread, nylon, size 3 (WP 0052 00, Table 1, Item 47)
 Thread, nylon, size 5 (WP 0052 00, Table 1, Item 48)
 Thread, nylon, size E (WP 0052 00, Table 1, Item 50)
 Thread, nylon, size FF (WP 0052 00, Table 1, Item 51)
 Tape, fastener, hook (WP 0052 00, Table 1, Item 34)
 Tape, fastener, pile (WP 0052 00, table 1, item 36)
 Cloth, Duck, Textured Nylon, Class III, CG 483 (WP 0052 00, Table 1, Item 78)
 Dyed dark gray nylon, 9.0 oz, (WP 0052 00, Table 1, Item 16)
 Webbing, nylon, type VIII, CG 483, (WP 0052 00, table 1, Item 61)
 Type XII binding tape (WP 0052, Table 1, Item 31)

Equipment Condition

N/A

INSPECT

Perform a before and after technical/rigger type inspection of the Parachute Drop Bag (PDB) as outlined in WP 0008 00.

REPAIR

The PDB nylon fabric on the main compartment, to include cargo pockets, lowering line stow pocket, incorporated leg strap retainer and retainer flap, incorporated single point release assembly, and exterior and interior shoulder straps may be restitched, darned and patched. When making any of these repairs, remove stitching as necessary to gain access to the damaged area. After repairs have been made, replace any stitching that has been removed, as in the original construction or as specified in each procedure. Repair by restitching, darning, and patching as described below.

1. Restitching. Restitch the main compartment fabric directly over old stitching using size E thread, 6 to 9 stitches per inch, and a MD sewing machine. Lock stitching at least $\frac{1}{2}$ -inch. Restitch loose or broken stitching on the body of the main compartment, outer binding tape, Lowering line stow pocket, incorporated leg strap retainer and retainer flap, YKK zipper, and canteen pockets.
2. Darning. Darn a hole or tear in the main compartment fabric, canteen pockets, or single point release assembly cover that does not exceed 1-inch in length or diameter using size FF thread and a darning machine. There is no limit to darns that may be applied, provided they do not weaken or reduce the strength of the fabric more than 10%.
3. Patching. There is no limit to the number of times the main compartment may be patched. Patch a hole or tear that exceeds 1-inch in diameter following the procedures in a) or b) below. Use cloth, duck, textured nylon, Class III on the exterior and dyed dark gray Cordura nylon, 9.0 oz on the interior according to the original construction for patching. Use a MD sewing machine, size FF thread, and 6 to 9 stitches per inch.
 - a. To patch the main compartment cut the Nylon patch 2-inches beyond circumference of the damaged portion. Turn under edges of patch $\frac{1}{2}$ -inch and center patch over the damaged area. Sew to the main compartment with a double row of stitching.
 - b. To patch a lined portion of the main compartment, (exterior and interior shoulder straps) when the felt is not damaged, cut the nylon fabric patch two inches beyond circumference of damaged portion. Turn under edges of the patch $\frac{1}{2}$ -inch and center patch over damaged area. Sew patch to exterior and interior shoulder straps with a double row of stitching as shown.

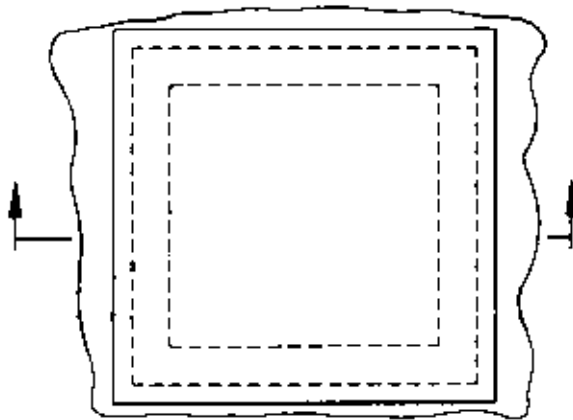

- c. To patch-lined portion of the shoulder straps when the felt is damaged, remove the damaged felt as described in (d) below. Cut a piece of felt the same size as the piece removed, and position felt plug and cordura patch (with the edges turned under 1/2-inch) over the damaged area. Sew a single box stitch formation as shown.

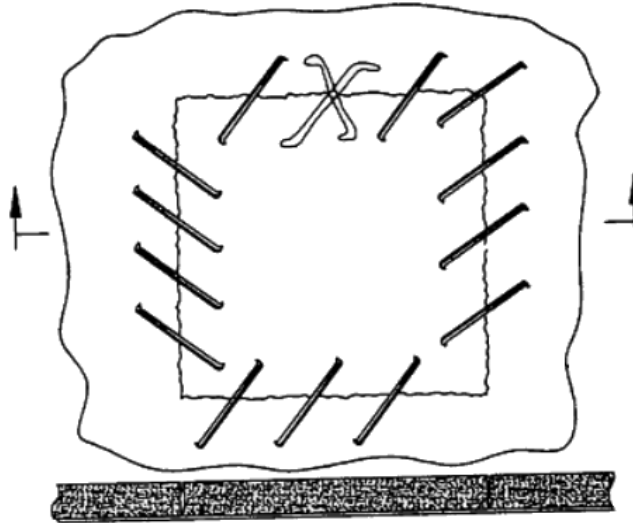

- d. To plug the felt lining of the container, mark a rectangle around the damaged area. Remove the damaged felt being careful not to damage the nylon material. Cut a piece of felt the size of the piece removed. Position felt plug into area cleared and sew as shown.
4. Repair of binding tape. Overlap the binding tape extending the new tape at least 1-inch beyond the damaged tape. Stitch tape with two rows of stitching $\frac{1}{8}$ -inch and $\frac{1}{4}$ -inch from edge of the tape as in the original construction using size E thread, 7 to 11 stitches per inch and a MD sewing machine.
 5. Repairing Webbing **(1)**. If the webbing is inadvertently damaged when stitching is being removed, the webbing will be replaced or the PDB will need to be removed from service.
 - a. **General.** The webbing on the main compartment may be restitched or replaced if authorized in this manual. This includes, the vertical straps, shoulder strap reinforcement, bottom shoulder strap attaching point, bottom vertical strap loop, and shoulder straps.
 - b. **Restitching.** Restitch loose, broken or defective stitching according to original construction using size FF thread, 6 to 9 stitches per inch, if webbing is used as a lifting point use size 5 thread, 4 to 6 stitches per inch and a HD sewing machine. Lock stitching at least $\frac{1}{2}$ -inch.
 6. Repair lowering line stow pocket **(2)** by restitching. Use size FF thread, 6 to 9 stitches per inch, and a MD sewing machine. Locking stitching at least $\frac{1}{2}$ -inch.
 7. Repair incorporated leg strap stow pocket by restitching. Use FF thread, 6 to 9 stitches per inch, and a MD sewing machine. Locking stitching at least $\frac{1}{2}$ -inch.
 8. Repair vertical straps **(3)** and vertical strap keepers **(4)** by restitching. Use 5 thread for 301 stitching, 4 to 6 stitches per inch, for box X stitching use size 5 thread, 4 to 6 stitches per inch and a HD sewing machine.

NOTE

V stitching runs parallel to webbing edges.

9. Repair Shoulder strap reinforcement (**5**) by restitching using (a double-VV w/Box-Stitch formation) size 5 thread, 4 to 6 stitches per inch and a HD sewing machine.
10. Repair bottom shoulder strap attaching point (**6**) by using a double box X stitch formation using size 3 thread, 5 to 8 stitches per inch and a HD sewing machine.

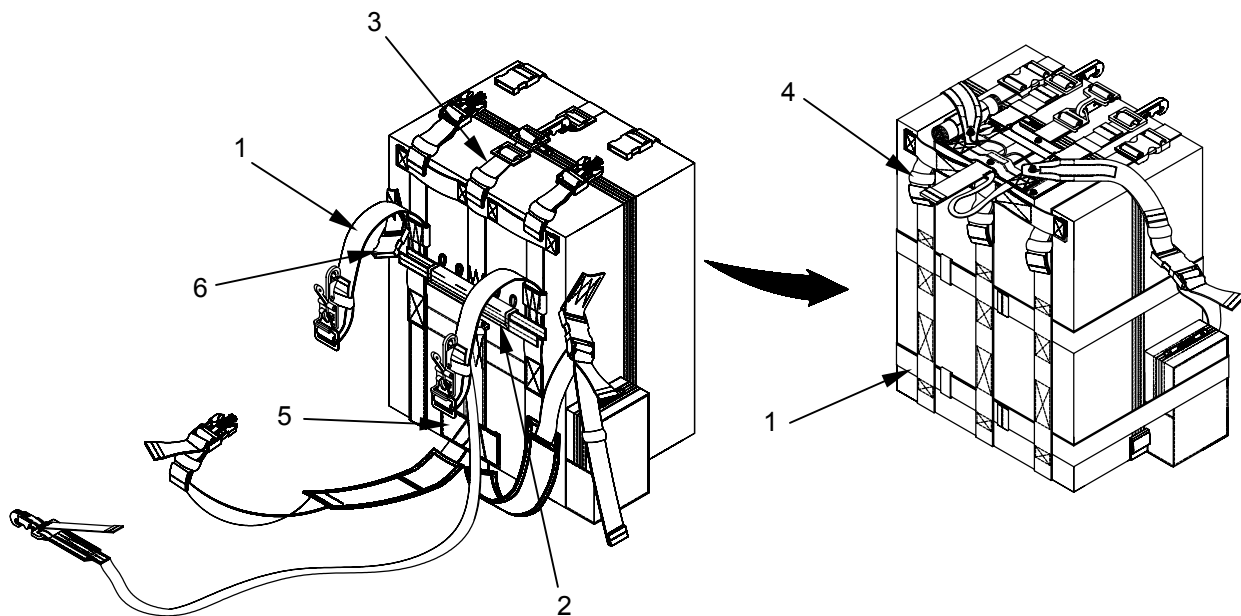

REPLACE

Only minor replacements will be authorized on the Parachutist Drop Bag (PDB), All major repairs will be sent back to manufacture unless authorized per the instruction in following paragraphs:

1. Vertical Straps Assembly, Center Vertical Strap and Restitch and Replace Metal Hardware.
 - a. Center vertical strap **(7)**, webbing, OD, nylon type XIII, if restitching sew using size 5 thread, 4 to 6 stitches per inch, and a MD sewing machine.
 - b. Replace damaged hardware, Ring, V-quick fit, Snap Hook **(8)**, Metal Slide **(9)**, with new metal hardware as in original construction.
 - (1) Replace damaged quick fit V-ring **(10)** by pulling the center vertical strap out from under the Single Point Release (SPR) cross strap, remove all access in center vertical strap and remove damaged quick fit v-ring and replace.
 - (2) Replace by grasping the center vertical strap at the point where it is sewn to the main compartment, trace the strap upwards toward the SPR assembly removing any twists, routing the center vertical strap up through the center of the quick fit v-ring. Ensure the fat portion of the quick fit v-ring is down and facing towards the bottom main compartment, and route back down through quick fit v-ring.
 - (3) Reroute center vertical strap under SPR assembly.
 - c. Replace damaged hardware, Snap Hook **(8)** or Metal Slide **(9)** with new metal hardware as in original construction.

NOTE

If replacing Metal Slide, remove and replace with serviceable hardware.

- (1) Carefully cut and remove the stitching at the folded end of the Center Vertical Strap. Pull the center vertical strap from metal slide, remove snap hook, and replace.
- (2) Replace by grasping the center vertical strap at the point where sewn and routed under the vertical strap loop (Webbing, OD, nylon type XIII).
- (3) Trace the center vertical strap upwards toward the SPR assembly, removing any twists. Route the center vertical strap through the snap hook as in original construction. Fold the end of the strap as in original construction and stitch using size 3 thread, 5 to 8 stitches per inch, and a HD sewing machine.

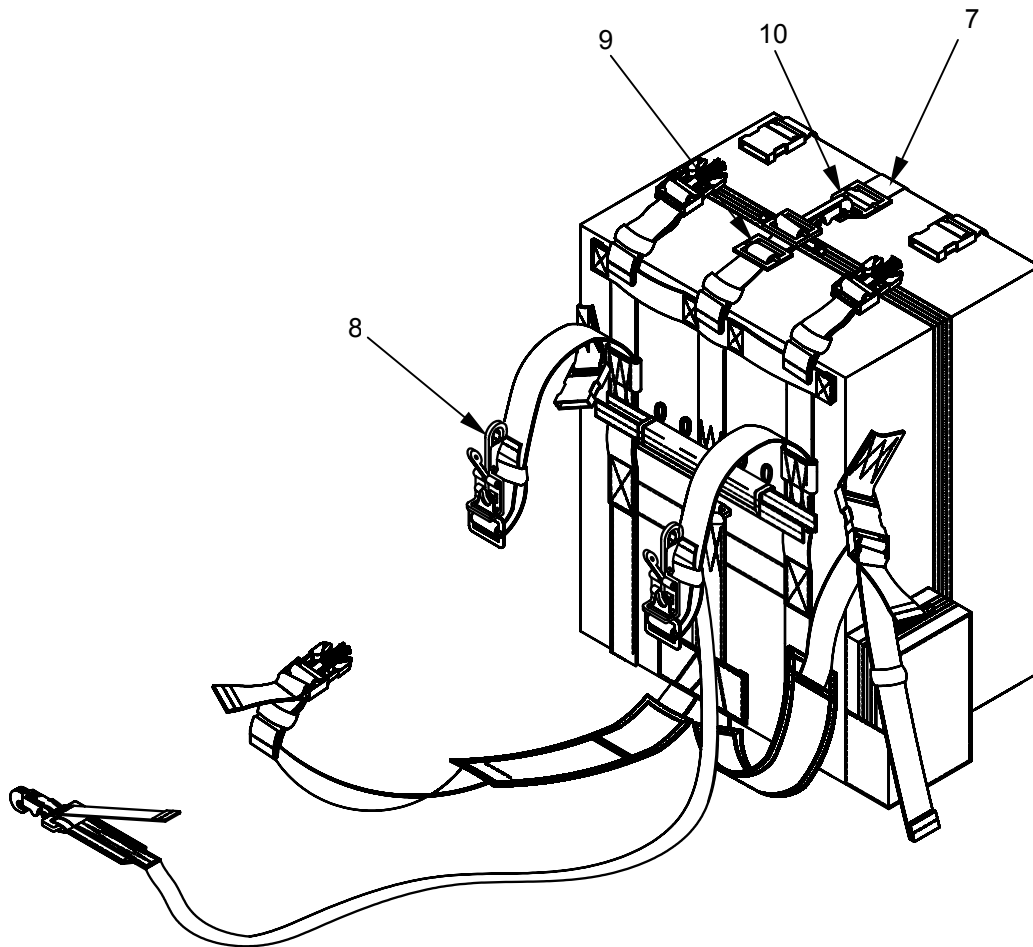

2. Outside Vertical Straps. Restitch and Replace Male and Female Quick Release Buckles.
 - a. Restitch Outside Vertical Strap **(11)**, webbing, OD, nylon seat belt material commercial grade, and restitch using size 5 thread, 4 to 6 stitches per inch and a MD sewing machine as in the original construction. Replace damaged Male quick release buckle **(12)**, or a female quick release buckle **(13)**. Replace with a serviceable quick release buckle as in original construction.
 - b. To replace damaged male quick release buckle **(12)**, or outside vertical strap **(11)**, remove all excess in the outside vertical strap and remove damaged male quick release buckle. Replace with a serviceable quick release buckle.
 - c. Replace by grasping the outside vertical strap at the point where sewn to the main compartment, trace the strap upwards toward the buckle assembly removing any twists, routing the outside vertical strap up through the buckle. Ensure the portion of the buckle with the lip is facing up as you route the strap through the bottom of the buckle and route back down through buckle.
 - d. To replace damaged, female quick release buckle **(13)**, or outside vertical strap, remove all excess in the outside vertical strap **(11)**, and remove damaged female buckle. Replace with a serviceable quick release buckle.
 - e. Replace by grasping the outside vertical strap **(11)** at the point where sewn to the main compartment, trace the strap upwards toward the buckle assembly removing any twists, routing the outside vertical strap up through the buckle. Ensure the portion of the buckle with the lip is facing up as you route the strap through the bottom of the buckle and route back down through buckle.
3. Compression Straps **(14)**. Webbing, OD, nylon seat belt material commercial grade, re-sew using size 5 thread, 4 to 6 stitches per inch and a MD sewing machine as in the original construction. The only authorized repairs will be to restitch or replace female and male quick release buckles. Replace compression strap as described below.

NOTE

No splicing of the compression strap is authorized.

- a. Remove damaged compression strap **(14)** and replace with a new compression strap as in original construction. If restitching, use size FF thread, Box X, stitch formation 6 to 9 stitches per inch and a MD sewing machine.
- b. Remove and replace damaged compression strap, with a new strap as in original construction. Remove compression strap by pulling from one end and removing compression strap from vertical strap channel and discard.
- c. Replace compression strap by re-routing new strap through the vertical strap channels going from one side to the other as in original construction.
- d. If replacing damaged female quick release buckle, remove the compression strap from the main compartment and carefully cut and remove stitching at the folded end and box X, of the compression strap, that secures the damaged buckle.

- e. Remove damaged buckle and replace with a serviceable buckle and sew compression strap as in the original construction using size FF thread, 6 to 9 stitches per inch and a MD sewing machine.
- f. If replacing damaged male quick release buckle, replace by grasping compression strap and trace to the end ensuring all twists are taken out.
- g. Route the compression strap up through the buckle ensuring the portion of the buckle with the lip is facing up as you route the strap through the bottom of the buckle and route back down through buckle.

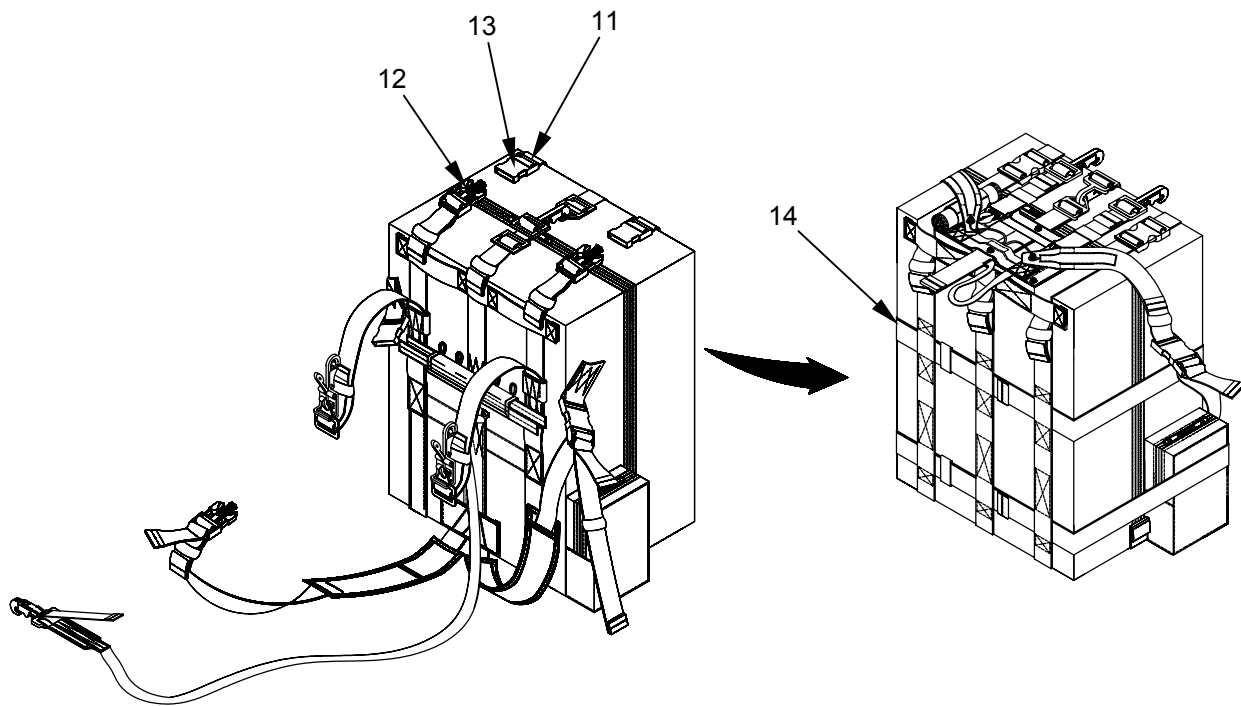

-
4. Breakaway Leg Strap **(15)**. Webbing, OD, nylon seat belt material commercial grade, re-sew using size 5 thread, 4 to 6 stitches per inch and a MD sewing machine as in the original construction. The only authorized maintenance on the breakaway leg strap is replacement or restitch as described below:
 - a. Replacement of the female quick release buckle is authorized for this item.
 - b. Restitching is authorized only to repair broken stitches. If the leg strap is cut it must be replaced with a new item from stock.
 - c. To replace damaged female buckle, take up excess in the leg strap and remove buckle. Replace with a serviceable buckle as in the original construction.
 - d. When placing a serviceable female buckle back onto the breakaway leg strap, make certain the cable guide, $\frac{1}{2}$ -inch OD nylon tape, is facing up.
 - e. Route the leg strap up through the female buckle; make certain that the lip on the female buckle is facing up.
 5. Lowering Line Assembly **(16)**. The only maintenance authorized on the lowering line assembly is restitching or replacement of hook and pile fastener.
 - a. When restitching broken stitching use size FF thread, 6 to 9 stitches per inch and a MD sewing machine on end loops. If repairing or replacing hook & pile tape fastener use size E thread, 7 to 11 stitches per inch and a LD sewing machine.
 - b. To replace hook and pile fastener on the lowering line proceed as follows:
 - (1) Cut the stitching and remove damaged hook or pile fastener from the lowering line.
 - (2) With pile side facing up, cut lengths as prescribed below. Replace both as in original construction; sew using E thread, 7 to 11 stitches per inch and a LD sewing machine.
 - (3) If replacing pile fastener on the topside looped end, cut 1-inch pile tape to a length of $11 \frac{1}{2}$ -inches.
 - (4) If replacing pile fastener on the snap hook side cut 1-inch pile tape to length of $2 \frac{1}{2}$ -inches. Replace both as in original construction; sew using E thread, 7 to 11 stitches per inch and a LD sewing machine.

- c. To replace hook fastener proceed as follows:
 - (1) Cut the stitching and remove damaged hook fastener from the lowering line.
 - (2) With hook side facing up, cut the lengths as prescribed below. Replace as in original construction, sew using size E thread, 7 to 11 stitches per inch and a LD sewing machine.
 - (3) If replacing hook fastener on the looped end, cut 1-inch hook tape to a length of 2-inches.
 - (4) If replacing hook fastener on the snap hook end, cut 1-inch hook tape to a length of 2 1/2-inches.

- d. To replace hook and pile fastener on the lowering line stow pocket (2) proceed as follows:
 - (1) To repair or replace hook & pile fastener, use size E thread, 7 to 11 stitches per inch and a LD sewing machine.
 - (2) Cut the stitching and remove damaged hook or pile fastener from the lowering line stow pocket. Lowering line stow pocket opened.
 - (3) To replace the hook fastener, cut a piece of 1-inch hook fastener to length of 13 1/2-inches and place on the pocket as in the original construction, sew using E thread, 7 to 11 stitches per inch and a LD sewing machine.
 - (4) To replace the pile fastener, cut a piece of 1-inch pile fastener to a length of 13 1/2-inches and place on to the pocket as in original construction, sew using E thread, 7 to 11 stitches per inch and a LD sewing machine.
 - (5) To replace the pile fastener on the outside flap, with the lowering line stow pocket closed, cut a piece of 2-inch pile fastener to a length of 8 1/2-inches and place onto pocket as in original construction, sew using E thread, 7 to 11 stitches per inch and a LD sewing machine.

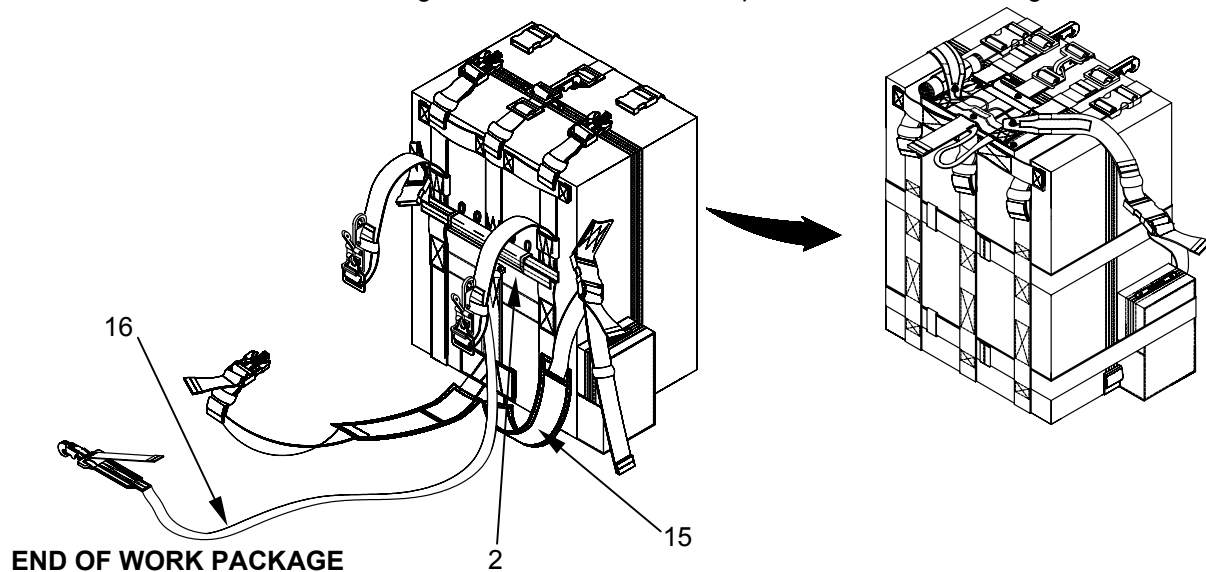

UNIT MAINTENANCE**ANCILLARY EQUIPMENT FOR PERSONNEL PARACHUTE SYSTEM****PREPARATION FOR STORAGE****INITIAL SETUP:****Tools**

N/A

Personnel Required

92R(10) Parachute Rigger

Materials/Parts

N/A

Equipment Condition

Unpacked

STORAGE CRITERIA

Administrative storage of Ancillary Equipment for Personnel Parachute System will be accomplished in accordance with AR 750-1, and the instructions furnished below.

GENERAL STORAGE REQUIREMENTS

To ensure that serviceability standards of the stored items are maintained, every effort will be exerted to adhere to the following general storage requirements:

1. When available, a heated building should be used to store equipment.
2. Ancillary Equipment will be stored in a dry, well-ventilated location and protected from pilferage, dampness, fire, dirt, insects, rodents, and direct sunlight.
3. Equipment will not be stored in a manner which would prevent ventilation or interfere with light fixtures, heating vents, fire fighting devices, cooling units, exits, or fire doors.
4. Equipment will not be stored in a damaged, dirty, or damp condition.
5. All stored items will be marked, segregated, and located for accessibility and easy identification.
6. Equipment will not be stored in direct contact with any building floor or wall. Storage will be accomplished using bins, shelves, pallets, racks, or dunnage to provide airspace between the storage area floor and the equipment. If the pre-constructed shelving or similar storage accommodations are not available, locally fabricate storage provisions using suitable lumber or wooden boxes.
7. All available material handling equipment should be used as much as possible in the handling of Ancillary Equipment.
8. Periodic rotation of stock, conversion of available space, proper housekeeping policies, and strict adherence to all safety regulations will be practiced at all times.

STORAGE SPECIFICS FOR ANCILLARY EQUIPMENT FOR PERSONNEL PARACHUTE SYSTEM

In addition to the storage requirements stipulated in the general storage requirements paragraph, above, the following is a list of specifics that must be enforced when storing ancillary equipment:

1. Equipment will be secured from access by unauthorized personnel.

2. Equipment that is in storage, and is administered a cyclic inspection, will not be exposed to incandescent light or indirect sunlight for a period of more than 36-hours. In addition, exposure to direct sunlight will be avoided entirely.

END OF WORK PACKAGE

UNIT MAINTENANCE

ANCILLARY EQUIPMENT FOR PERSONNEL PARACHUTE SYSTEM

PREPARATION FOR SHIPMENT
IN STORAGE INSPECTION, SHIPMENT

INITIAL SETUP:

Tools

N/A

Personnel Required

92R(10) Parachute Rigger

Materials/Parts

N/A

Equipment Condition

Unpacked

IN-STORAGE INSPECTION

General Information. An in-storage inspection is a physical check conducted on a random sample of airdrop equipment that is located in storage. Authorized rigger personnel (MOS 92R(20)) will conduct this inspection.

Intervals. Equipment in storage will be inspected at least semiannually and at more frequent intervals if prescribed by the local parachute maintenance officer.

Inspection. Inspect to ensure that the equipment is ready for issue.

1. Check the items for proper identification.
2. Check that no damage or deterioration has been incurred.
3. Ensure that all modifications, or similar requirements, have been completed.
4. Check the adequacy of the storage facilities, efforts taken to control pests and rodents, and protection against unfavorable climatic conditions.

SHIPMENT

Initial Shipment. The initial packaging and shipping of ancillary equipment is the responsibility of item manufacturers, who are required to comply with federal and military packing specifications, as stipulated in contractual agreements. Equipment are normally shipped to depot activities, by domestic freight or parcel post, and packed to comply with overseas shipping requirements. Except for those items that are unpackaged and subjected to random inspections or testing by depot activity, equipment received by a using unit will be contained in the original packaging materials.

Shipping Between Maintenance Activities. The shipping of equipment between activities will be accomplished on a signature verification basis using whatever means of military transportation is available. Used equipment and other fabric items will be tagged in accordance with DA PAM 738-751, and rolled, folded, or placed loosely in a suitable container, as required. Unused equipment will be transported in original shipping containers. During shipment, every effort will be made to protect equipment from weather elements, dust, dirt, oil, grease, and acids. Military vehicles used to transport equipment will be inspected to ensure the items are protected from the previously cited material damaging conditions.

Other Shipping Instructions. Equipment destined for domestic or overseas shipment will be packaged and marked in accordance with AR 700-15, TM 38-230-1, and TM 38-230-2. Shipment of equipment will be accomplished in accordance with TM 10-1670-201-23.

END OF WORK PACKAGE

TM 10-1670-299-20&P

**CHAPTER 3
SUPPORTING INFORMATION
FOR
ANCILLARY EQUIPMENT FOR PERSONNEL PARACHUTE SYSTEM**

**ANCILLARY EQUIPMENT FOR PERSONNEL PARACHUTE SYSTEM
REFERENCES**

SCOPE

This Work Package lists all forms, technical manuals, and miscellaneous publications referenced in this manual.

PUBLICATION INDEXES

The following publication indexes should be consulted frequently for the latest changes or revisions of references given in this work package, and for new publications relating to the material covered in this manual:

DA PAM

Consolidated Index of Army Publications and Blank Forms	DA PAM 25-30
Functional Users Manual for The Army Maintenance Management System (TAMMS)	DA PAM 738-750
Functional Users Manual for The Army Maintenance Management System (Aviation) (TAMMSA)	DA PAM 738-751

TECHNICAL MANUALS

General Maintenance of Parachutes and Other Airdrop Equipment	TM 10-1670-201-23/ T.O. 13C-1-41/ NAVAIR 13-1-17
Preservation, Packaging, Packing of Military Supplies and Equipment (Vols. 1 and 2)	TM 38-230-1 and TM 38-230-2
Equipment Maintenance Forms and Procedures	TM 4700-15/1/
Procedures for the Destruction of Air Delivery Equipment to Prevent Enemy Use	TM 43-0002-1/ T.O. 13C3-1-10/ NAVAIR 13-1-19

FIELD MANUALS

First Aid for Soldiers	FM 4-25.11
General Repair for Tents, Canvas and Webbing	FM 10-16

ARMY REGULATIONS

Dictionary of United States Army Terms	AR 310-25
Authorized Abbreviation and Brevity Codes and Acronyms	AR-310-50
Packaging of Material	AR 700-15
Army Material Maintenance Concepts and Policy and Retail Maintenance Operations	AR 750-1
Air Drop, Parachute Recovery and Aircraft Personal Escape Systems	AR 750-32

TECHNICAL BULLETINS

Maintenance Expenditure Limits for FSC Group 16, FSC Class 1670	TB 43-0002-43
---	---------------

FORMS

Parachute Log Record	DA Form 3912
Equipment Inspection & Maintenance Worksheet	DA Form 2404
Supply Discrepancy Report	SF 364
Product Quality Deficiency Report	SF 368
Recommended Changes to Publications and Forms	DA Form 2028
Recommended Changes to Equipment Technical Publications	DA Form 2028-2
Uncorrected Fault Record	DA Form 2408-14

AIR FORCE TECHNICAL ORDER FORMS

Parachute Log	AFTO 391
Parachute Repack Inspection and Component Card	AFTO 392

MARINE CORPS FORMS

Marine Corps Military Incentive Awards Program	MCO 1650.17F
Parachute History Record	NAV WPN CEN or NAV WPNS CL 13512/11
Product Quality Deficiency Report (PQDR)	MCO 4855.10B
Recommended Changes to Technical Publications	NAVMC 10772

END OF WORK PACKAGE

**UNIT MAINTENANCE
ANCILLARY MILITARY FREE-FALL EQUIPMENT
MAINTENANCE ALLOCATION CHART, INTRODUCTION**

INTRODUCTION

The Army Maintenance System MAC

This introduction provides a general explanation of all maintenance and repair functions authorized at various maintenance levels under the standard Army Maintenance System concept.

The MAC (immediately following the introduction) designates overall authority and responsibility for the performance of maintenance functions on the identified end item or component. The application of the maintenance functions to the end item or component shall be consistent with the capacities and capabilities of the designated maintenance levels, which are shown on the MAC in column (4) as:

Unit - includes two subcolumns, C (operator/crew) and O (unit) maintenance

Direct Support - includes an F subcolumn

General Support - includes an H subcolumn

Depot - includes a D subcolumn

The tools and test equipment requirements (immediately following the MAC) list the tools and test equipment (both special tools and common tool sets) required for each maintenance function as referenced from the MAC.

The remarks (immediately following the tools and test equipment requirements) contain supplemental instructions and explanatory notes for a particular maintenance function.

Maintenance Functions

Maintenance functions are limited to and defined as follows:

1. **Inspect.** To determine the serviceability of an item by comparing its physical, mechanical, and/or electrical characteristics with established standards through examination (e.g., by sight, sound, or feel). This includes scheduled inspection and gagings and evaluation of cannon tubes.
2. **Test.** To verify serviceability by measuring the mechanical, pneumatic, hydraulic, or electrical characteristics of an item and comparing those characteristics with prescribed standards on a scheduled basis, i.e., load testing of lift devices and hydrostatic testing of pressure hoses.
3. **Service.** Operations required periodically to keep an item in proper operating condition, i.e. to clean (includes decontaminate, when required), to preserve, to drain, to paint, or to replenish fuel, lubricants, chemical fluids, or gases. This includes scheduled exercising and purging of recoil mechanisms.
4. **Adjust.** To maintain or regulate, within prescribed limits, by bringing into proper or exact position, or by setting the operating characteristics to specified parameters.
5. **Align.** To adjust specified variable elements of an item to bring about optimum or desired performance.

6. Calibrate. To determine and cause corrections to be made or to be adjusted on instruments of test, measuring, and diagnostic equipment used in precision measurement. Consists of comparisons of two instruments, one of which is a certified standard of known accuracy, to detect and adjust any discrepancy in the accuracy of the instrument being compared.
7. Remove/Install. To remove and install the same item when required to perform service or other maintenance functions. Install may be the act of emplacing, seating, or fixing into position a spare, repair part, or module (component or assembly) in a manner to allow the proper functioning of equipment or system.
8. Replace. To remove an unserviceable item and install a serviceable counterpart in its place. "Replace" is authorized by the MAC and assigned maintenance level is shown as the third position code of the Source, Maintenance, and Recoverability (SMR) code.
9. Repair. The application of maintenance services, including fault location/troubleshooting, removal/installation, and disassembly/assembly procedures, and maintenance actions to identify troubles, and restore serviceability to an item by correcting specific damage, fault, malfunction, or failure in a part, subassembly, module (component or assembly), end item, or system.

NOTE

The following definitions are applicable to the "repair" maintenance function:

Services - Inspect, test, service, adjust, align, calibrate, and/or replace.

Fault location/troubleshooting - The process of investigating and detecting the cause of equipment malfunctioning; the act of isolating a fault within a system or Unit Under Test (UUT).

Disassembly/assembly - The step-by-step breakdown (taking apart) of a spare/functional group coded item to the level of its least component, that is assigned an SMR code for the level of maintenance under consideration (i.e., identified as maintenance significant).

Actions - Welding, grinding, riveting, straightening, facing, machining, and/or resurfacing.

10. Overhaul. That maintenance effort (service/action) prescribed to restore an item to a completely serviceable/operational condition as required by maintenance standards in appropriate technical publications. Overhaul is normally the highest degree of maintenance performed by the Army. Overhaul does not normally return an item to like new condition.
11. Rebuild. Consists of those services/actions necessary for the restoration of unserviceable equipment to a like new condition in accordance with original manufacturing standards. Rebuild is the highest degree of material maintenance applied to Army equipment. The rebuild operation includes the act of returning to zero those age measurements (e.g., hours/miles, etc.) considered in classifying Army equipment/components.

Explanation of Columns in the MAC

Column (1) - Group Number. Column (1) lists FGC numbers, the purpose of which is to identify maintenance significant components, assemblies, subassemblies, and modules with the Next Higher Assembly (NHA).

Column (2) - Component/Assembly. Column (2) contains the item names of components, assemblies, subassemblies, and modules for which maintenance is authorized.

Column (3) - Maintenance Function. Column (3) lists the functions to be performed on the item listed in Column (2). (For a detailed explanation of these functions, refer to "Maintenance Functions" outlined above.)

Column (4) - Maintenance Level. Column (4) specifies each level of maintenance authorized to perform each function listed in column (3), by indicating work time required (expressed as manhours in whole or decimals) in the appropriate subcolumn. This work time figure represents the active time required to perform that maintenance function at the indicated level of maintenance. If the number or complexity of the tasks within the listed maintenance function varies at different maintenance levels, appropriate work time figures are to be shown for each level. The work time figure represents the average time required to restore an item (assembly, subassembly, component, module, end item, or system) to a serviceable condition under typical field operating conditions. This time includes preparation time (including any necessary assembly/disassembly time), troubleshooting/fault location time, and quality assurance time in addition to the time required to perform the specific tasks identified for the maintenance functions authorized in the MAC. The symbol designations for the various maintenance levels are as follows:

- C -- Operator or crew
- O -- Unit Maintenance
- F -- Direct Support Maintenance
- L -- Specialized Repair Activity (SRA)
- D -- Depot Maintenance
- H -- General Support Maintenance

NOTE

The "L" maintenance level is not included in column (4) of the MAC. Functions to this level of maintenance are identified by a work time figure in the "H" column of column (4), and an associated reference code is used in the REMARKS column (6). This code is keyed to the remarks and the SRA complete repair application is explained there.

Column (5) - Tools and Equipment Reference Code. Column (5) specifies, by code, those common tool sets (not individual tools) common Test, Measurement and Diagnostic Equipment (TMDE), and special tools, special TMDE and special support equipment required to perform the designated function. Codes are keyed to the entries in the tools and test equipment table.

Column (6) - Remarks Code. When applicable, this column contains a letter code, in alphabetical order, which is keyed to the remarks table entries.

Explanation of Columns in the Tools and Test Equipment Requirements

Column (1) - Tool or Test Equipment Reference Code. The tool or test equipment reference code correlates with a code used in column (5) of the MAC.

Column (2) - Maintenance Level. The lowest level of maintenance authorized to use the tool or test equipment.

Column (3) - Nomenclature. Name or identification of the tool or test equipment.

Column (4) - National Stock Number (NSN). The NSN of the tool or test equipment.

Column (5) - Tool Number. The manufacturer's part number, model number, or type number.

Explanation of Columns in the Remarks

Column (1) - Remarks Code. The code recorded in Column (6) of the MAC.

Column (2) - Remarks. This column lists information pertinent to the maintenance function being performed as indicated in the MAC.

**UNIT MAINTENANCE
ANCILLARY EQUIPMENT FOR PERSONNEL PARACHUTE SYSTEM
MAINTENANCE ALLOCATION CHART**

Table 1. Maintenance Allocation Chart (MAC) for Ancillary Equipment for Personnel Parachute System.

(1) GROUP NUMBER	(2) ASSEMBLY	(3) MAINT. FUNCTION	(4) MAINTENANCE LEVEL					(5) TOOLS & EQUIPMENT CODE	(6) REMARKS
			UNIT		DIRECT SUPPORT	GENERAL SUPPORT	DEPOT		
			C	O	F	H	D		
00	PERSONNEL TROOP PARACHUTE SYSTEM								
01	EXTENSION, STATIC LINE, STANDARD, 5-FT	Inspect		0.2				1,2	A
		Install		0.2					
		Replace		0.2					
		Repair		0.2					
02	ACCESSORY SET, SCUBA	Inspect		0.4				1,2,5	A,B
		Install		0.5					
		Repair		0.2					
		Replace		0.1					
0201	SUPPORT STRAP	Inspect		0.1				1,2	B
		Repair		0.2					
		Replace		0.1					
0202	BACKSTRAP, HARNESS	Inspect		0.1				1,2	B
		Repair		0.2					
		Replace		0.5					
0203	STRAP, WAISTBAND EXTENSION	Inspect		0.1				1,2	B
		Repair		0.2					
		Replace		0.2					
0204	SHIELD	Inspect		0.1				5	A
		Repair		0.2					
		Replace		0.1					
03	LINE, LOWERING 15-FOOT	Inspect		0.1				1,2	B
		Repair		0.5					
		Replace		0.1					
04	JUMP PACK, DRAGON MISSILE	Inspect		0.2				1,2	A
		Repair		0.5					
		Replace		0.5					

Table 1. Maintenance Allocation Chart (MAC) for Ancillary Equipment for Personnel Parachute System.

(1) GROUP NUMBER	(2) ASSEMBLY	(3) MAINT. FUNCTION	(4) MAINTENANCE LEVEL				(5) TOOLS & EQUIPMENT CODE	(6) REMARKS	
			UNIT		DIRECT SUPPORT	GENERAL SUPPORT			DEPOT
			C	O	F	H			D
05	HARNES, SINGLE POINT RELEASE	Inspect		0.3				1,2,3,4	A
		Repair		0.2					
		Replace		0.1					
0501	STRAP, LEG RELEASE	Inspect		0.1				1,2	A
		Repair		0.2					
		Replace		0.1					
0502	HANDLE, RELEASE	Inspect		0.1				1,2	A
		Repair		0.2					
		Replace		0.1					
0503	STRAP, HARNES ATTACHING	Inspect		0.1				1,2	A
		Repair		0.2					
		Replace		0.1					
06	PACK, ASSEMBLY, AT4	Inspect		0.2				1,2	A
		Repair		0.5					
		Replace		0.2					
07	CASE, PARACHUTIST'S INDIVIDUAL WEAPON M-1950 (COTTON)	Inspect		0.2				1,2	A
		Repair		0.5					
		Replace		0.2					
08	CASE, PARACHUTIST'S INDIVIDUAL WEAPON M-1950 (NYLON)	Inspect		0.2				1,2	A
		Repair		0.5					
		Replace		0.2					
09	PARACHUTIST'S WEAPON AND INDIVIDUAL EQUIPMENT PACK AND HARNES ASSEMBLY	Inspect		0.2				1,2	A
		Repair		0.5					
		Replace		0.2					
0901	PACK	Inspect		0.2				1,2	A
		Repair		0.5					
		Replace		0.2					

Table 1. Maintenance Allocation Chart (MAC) for Ancillary Equipment for Personnel Parachute System.

(1) GROUP NUMBER	(2) ASSEMBLY	(3) MAINT. FUNCTION	(4) MAINTENANCE LEVEL				(5) TOOLS & EQUIPMENT CODE	(6) REMARKS	
			UNIT		DIRECT SUPPORT	GENERAL SUPPORT			DEPOT
			C	O	F	H			D
0902	HARNESS	Inspect		0.2					
		Repair		0.5				1,2	
		Replace		0.2					
10	JUMP PACK, STINGER MISSILE	Inspect		0.2					
		Repair		0.5				1,2,3	
		Replace		0.2					
11	RELEASE PARACHUTE INDIVIDUAL EQUIPMENT	Inspect		0.2					
		Repair		0.5				1,2,3	
		Replace		0.2					
12	CONTAINER, FRONT MOUNT	Inspect		0.2					
		Repair		0.5				1,2,3	
		Replace		0.2					
1201	CONTAINER	Inspect		0.2					
		Repair		0.5				1,2,3	
		Replace		0.2					
1202	HARNESS AND BODY ASSEMBLY	Inspect		0.2					
		Repair		0.5				1,2,3	
		Replace		0.2					
1203	RESTRAINT ASSEMBLY, HORIZONTAL	Inspect		0.2					
		Repair		0.5				1,2,3	
		Replace		0.2					
13	CONTAINER, SIDE MOUNT	Inspect		0.2					
		Repair		0.5				1,2,3	
		Replace		0.2					
1301	OUTER PADDED ASSEMBLY	Inspect		0.2					
		Repair		0.5				1,2,3	
		Replace		0.2					
1302	OUTER CAP ASSEMBLY	Inspect		0.2					
		Repair		0.5				1,2,3	
		Replace		0.2					
1303	LOWER CAP ASSEMBLY	Inspect		0.2					
		Repair		0.5				1,2,3	
		Replace		0.2					

Table 1. Maintenance Allocation Chart (MAC) for Ancillary Equipment for Personnel Parachute System.

(1) GROUP NUMBER	(2) ASSEMBLY	(3) MAINT. FUNCTION	(4) MAINTENANCE LEVEL				(5) TOOLS & EQUIPMENT CODE	(6) REMARKS	
			UNIT		DIRECT SUPPORT	GENERAL SUPPORT			DEPOT
			C	O	F	H			D
1304	UPPER BRIDLE ASSEMBLY	Inspect		0.2				1,2,3	A,B
		Repair		0.5					
		Replace		0.2					
1305	LOWERING LINE	Inspect		0.2				1,2,3	A,B
		Repair		0.5					
		Replace		0.2					
14	DROP BAG, PARACHUTIST	Inspect		0.2				1,2,3	A,B
		Repair		0.5					
		Replace		0.2					
1401	VERTICAL STRAPS	Inspect		0.2				1,2,3	A,B
		Repair		0.5					
1402	COMPRESSION STRAP	Inspect		0.2				1,2,3	A,B
		Repair		0.2					
		Replace		0.5					
1403	LOWERING LINE ASSEMBLY	Inspect		0.2				1,2,3	A,B
		Repair		0.5					
1404	ATTACHING STRAPS	Inspect		0.2				1,2,3	A,B
		Repair		0.2					
		Replace		0.2					
1405	BREAKAWAY LEG STRAPS	Inspect		0.2				1,2,3	A,B
		Repair		0.5					
		Replace		0.2					

Table 2. Tools and Test Equipment for Ancillary Equipment for Personnel Parachute Systems.

TOOL OR TEST EQUIPMENT REF CODE	MAINTENANCE LEVEL	NOMENCLATURE	NATIONAL STOCK NUMBER	TOOL NUMBER
1	O	Canvas Repair Kit	5180-00-754-0731	SCS180-90-CL-N07
2	O	Compressing Tool	5120-00-323-2296	0-3/16sc
3	O	Cutter, cable	5110-00-516-4217	
4	O	Cutters, Diagonal Pliers	5110-00-239-8253	A-A-2330
5	O	Double Bow Cutter	5110-00-180-0923	149-1/2
6	O	Knife	5110-00-162-2205	6400 45R
7	O	Knife, Hot, Metal	3439-01-197-7656	4025 (78976)
8	O	Lead Pig	9650-00-264-5050	QQ-C-40
9	O	Needle, Tacking	8315-00-262-3733	FF-N-180
10	O	Pot, Melting, Electric	5120-00-924-5213	L-115
11	O	Press, Hand Operated	5120-00-880-0619	A741
12	O	Punch and Die for O-Grommets	5120-00-357-5754	216-0
13	O	Rawhide Mallet	5120-00-293-3397	GGG-H-33
14	O	Screwdriver, Flat Tip	5120-00-278-1283	1007-6
15	O	Sewing Machine, Darning	3530-01-177-8589	OO-S-00256/16
16	O	Sewing Machine, HD	3530-01-177-8588	OO-S-00256/13
17	O	Sewing Machine, LD	3530-01-177-8590	OO-S-00256/13
18	O	Sewing Machine, MD	3530-01-177-8591	OO-S-00256/13
19	O	Sewing Machine, LD, Zig Zag	3530-01-181-1420	00-S-00256/14
20	O	Shears	5110-00-239-6370	GGG-5-278
21	O	Single Bow Cutter	5110-00-180-0941	GGG-P-833

Table 3. Remarks for Your Ancillary Military Free-Fall Equipment.

REMARKS CODE	REMARKS
A	Technical-rigger type inspection required.
B	Restitching only.

**UNIT AND DIRECT SUPPORT MAINTENANCE
ANCILLARY EQUIPMENT FOR PERSONNEL PARACHUTE SYSTEM
REPAIR PARTS AND SPECIAL TOOLS LIST INTRODUCTION**

SCOPE

This Repair Parts and Special Tools List (RPSTL) lists and authorizes spare and repair parts; special tools; special test, measurement and diagnostic equipment (TMDE); and other special support equipment required for performance of organizational, direct support and general support maintenance of the Ancillary Equipment for Personnel Parachute Systems. It authorizes the requisitioning, issue, and disposition of spares, repair parts, and special tools as indicated by the Source, Maintenance, and Recoverability (SMR) codes.

GENERAL

In addition to the Introduction Work Package, this RPSTL is divided into the following work packages:

1. Repair Parts List Work Packages. Work packages containing lists of spares and repair parts authorized by this RPSTL for use in the performance of maintenance. These work packages also include parts which must be removed for replacement of the authorized parts. Parts lists are composed of functional groups in ascending alphanumeric sequence, with the parts in each group listed in ascending figure and item number sequence. Bulk materials are listed by item name in FIG. BULK at the end of the work packages.
2. Special Tools List. (Not Applicable). No special tools are required to assemble the Ancillary Equipment. Common tools are normally listed in WP 0034 00 if they are required for maintenance procedures/tasks.
3. Cross-Reference Indexes Work Packages. There are 2 cross-reference indexes work packages in this RPSTL: (the National Stock Number (NSN) Index work package, and the Part Number (P/N) Index work package). The National Stock Number Index work package refers you to the figure and item number. The Part Number Index work package refers you to the figure and item number.

EXPLANATION OF COLUMNS IN THE REPAIR PARTS LIST AND SPECIAL TOOLS LIST WORK PACKAGES

ITEM NO. (Column (1)). Indicates the number used to identify items called out in the illustration.

SMR CODE (Column (2)). The Source, Maintenance, and Recoverability (SMR) code containing supply/requisitioning information, maintenance level authorization criteria and disposition instruction, as shown in the following breakout.

Source Code	Maintenance Code	Recoverability Code	
----	----	----	----
XX	X	X	X
----	----	----	----
1st two Positions: How to get an item.	3rd Position: Who can install, replace or use the item.	4th Position: Who can do complete repair* on the item.	5th Position: Who determines disposition action on unserviceable items.

* Complete Repair: Maintenance capacity, capability, and authority to perform all corrective maintenance tasks of the "Repair" function in a use/user environment in order to restore serviceability to a failed item.

Source Code. The source code tells you how to get an item needed for maintenance, repair, or overhaul of an end item/equipment. Explanation of source codes follow.

Source Code	Explanation
PA	Stock items; use the applicable NSN to request/requisition items with these source codes. They are authorized to the category indicated by the code entered in the third position of the SMR code.
PB	
PC**	
PD	
PE	
PF**	
PG	NOTE: Items coded PC are subject to deterioration.
KB	Items with these codes are not to be requested/requisitioned individually. They are part of a kit which is authorized to the maintenance level indicated in the 3rd position of the SMR code. The complete kit must be requisitioned and applied.
KD	
KF	
MO-(Made at Unit/AVUM Level)	Items with these codes are not to be requested/requisitioned individually. They must be made from bulk material which is identified by the P/N in the DESCRIPTION AND USABLE ON CODE (UOC) column and listed in the bulk material group work package of the RPSTL. If the item is authorized to you by the 3rd position code of the SMR code, but the source code indicates it is made at a higher level, order the item from the higher level of maintenance.
MF-(Made at DS/AVIM Level)	
MH-(Made at GS Level)	
ML-(Made at Specialized Repair Act (SRA))	
MD-(Made at Depot)	
AO-(Assembled by Unit/AVUM Level)	Items with these codes are not to be requested/requisitioned individually. The parts that make up the assembled item must be requisitioned or fabricated and assembled at the level of maintenance indicated by the source code. If the third position code of the SMR code authorizes you to replace the item, but the source code indicates the item is assembled at a higher level, order the item from the higher level of maintenance.
AF-(Assembled by DS/AVIM Level)	
AH-(Assembled by GS level)	
AL-(Assembled by SRA)	
AD-(Assembled by Depot)	
XA	Do not requisition an "XA" coded item. Order its next higher assembly. (Also, refer to the NOTE below.)
XB	If an "XB" item is not available from salvage, order it using the CAGEC and part number given.
XC	Installation drawing, diagram, instruction sheet, field service drawing, that is identified by manufacturer's part number.
XD	Item is not stocked. Order an "XD" coded item through normal supply channels using the CAGEC and part number given, if no NSN is available.

NOTE

Cannibalization or controlled exchange, when authorized, may be used as a source of supply for items with the above source codes, except for those source coded "XA" or those aircraft support items restricted by requirements of AR 750-1.

Maintenance Code. Maintenance codes tell you the level(s) of maintenance authorized to use and repair support items. The maintenance codes are entered in the third and fourth positions of the SMR Code as follows:

Third Position. The maintenance code entered in the third position tells you the lowest maintenance level authorized to remove, replace, and use the support item. The maintenance code entered in the third position will indicate authorization to one of the following levels of maintenance.

Maintenance

Code	Application/Explanation
C	Crew or operator maintenance done within unit/AVUM maintenance.
O	Unit level/AVUM maintenance can remove, replace, and use the item.
F	Direct support/AVIM maintenance can remove, replace, and use the item.
H	General support maintenance can remove, replace, and use the item.
L	Specialized repair activity can remove, replace, and use the item.
D	Depot level can remove, replace, and use the item.

Fourth Position. The maintenance code entered in the fourth position tells whether or not the item is to be repaired and identifies the lowest maintenance level with the capability to do complete repair (i.e., perform all authorized repair functions).

NOTE

Some limited repair may be done on the item at a lower level of maintenance, if authorized by the Maintenance Allocation Chart (MAC) and SMR codes.

Maintenance

Code	Application/Explanation
O	Unit/AVUM is the lowest level that can do complete repair of the item.
F	Direct support/AVIM is the lowest level that can do complete repair of the item.
H	General support is the lowest level that can do complete repair of the item.
L	Specialized repair activity is the lowest level that can do complete repair of the item.

- D Depot is the lowest level that can do complete repair of the item.
- Z Nonrepairable. No repair is authorized.
- B No repair is authorized. No parts or special tools are authorized for the maintenance of a "B" coded item. However, the item may be reconditioned by adjusting, lubricating, etc., at the user level.

Recoverability Code. Recoverability codes are assigned to items to indicate the disposition action on unserviceable items. The recoverability code is entered in the fifth position of the SMR Code as follows:

Code	Application/Explanation
Z	Nonreparable item. When unserviceable, condemn and dispose of the item at the level of maintenance shown in 3rd position of SMR Code.
O	Reparable item. When uneconomically repairable, condemn and dispose of the item at organizational or aviation unit level.
F	Reparable item. When uneconomically repairable, condemn and dispose of the item at the direct support level.
H	Reparable item. When uneconomically repairable, condemn and dispose of the item at the general support level.
D	Reparable item. When beyond lower level repair capability, return to depot. Condemnation and disposal of item not authorized below depot level.
L	Reparable item. Condemnation and disposal not authorized below Specialized Repair Activity (SRA).
A	Item requires special handling or condemnation procedures because of specific reasons (such as precious metal content, high dollar value, critical material, or hazardous material). Refer to appropriate manuals/directives for specific instructions.

National Stock Number (NSN) (Column (3)). The NSN for the item is listed in this column.

CAGEC (Column (4)). The Commercial and Government Entity Code (CAGEC) is a 5-digit code which is used to identify the manufacturer, distributor, or Government agency/activity that supplies the item.

PART NUMBER (Column (5)). Indicates the primary number used by the manufacturer (individual company, firm, corporation, or Government activity), which controls the design and characteristics of the item by means of its engineering drawings, specifications, standards, and inspection requirements to identify an item or range of items.

NOTE

When you use an NSN to requisition an item, the item you receive may have a different P/N from the number listed.

DESCRIPTION and Usable On Code (UOC) (Column (6)). This column includes the following information:

1. The federal item name and, when required, a minimum description to identify the item.
2. P/Ns of bulk materials are referenced in this column in the line entry to be manufactured/fabricated.
3. Hardness Critical Item (HCI). A support item that provides the equipment with special protection from electromagnetic pulse (EMP) damage during a nuclear attack.
4. The statement "END OF FIGURE" appears just below the last item description in Column (6) for a given figure in both the repair parts list and special tools list work packages.

QTY (Column (7)). The QTY (quantity per figure) column indicates the quantity of the item used in the breakout shown on the illustration/figure, which is prepared for a functional group, subfunctional group, or an assembly. A "V" appearing in this column instead of quantity indicates that the quantity is a variable with each application.

EXPLANATION OF CROSS-REFERENCE INDEXES WORK PACKAGES FORMAT AND COLUMNS

National Stock Number (NSN) Index Work Package.

STOCK NUMBER Column. This column lists the NSN in National item identification number (NIIN) sequence. The NIIN consists of the last nine digits of the NSN, i.e.,

NSN
5305-01-574-1467
NIIN

When using this column to locate an item, ignore the first four digits of the NSN. Use the complete NSN (13 digits) when requisitioning by stock number.

FIG. Column. This column lists the number of the figure where the item is identified/located. The figures are in the repair parts list and special tools list work packages.

ITEM Column. The Item number identifies the item associated with the figure listed in the adjacent FIG. Column. This item is also identified by the NSN listed on the same line.

2. Part Number (P/N) Index Work Package. P/Ns in this index are listed in ascending alphanumeric sequence (i.e., vertical arrangement of letter and number combinations which place the first letter or digit of each group in order A through Z, followed by the numbers 0 through 9, and each following letter or digit in like order).

PART NUMBER Column. Indicates the P/N assigned to the item.

FIG. Column. This column lists the number of the figure where the item is identified/located in the repair parts list and special tools list work packages.

ITEM Column. The item number is the number assigned to the item as it appears in the figure referenced in adjacent figure number column.

SPECIAL INFORMATION

USABLE ON CODE (UOC). The usable on code appears in the lower left corner of the Description Column heading. Usable on codes are shown as "UOC: ..." in the Description Column (justified left) on the first line under the applicable item/nomenclature. Uncoded items are applicable to all models. Identification of the usable on codes used in this RPSTL are:

Code**Used On**

No usable on codes assigned for this end item.

Fabrication Instructions. Bulk materials required to manufacture items are listed in the bulk material functional group of this RPSTL. Part numbers for bulk material are also referenced in the Description Column of the line item entry for the item to be manufactured/fabricated. Detailed fabrication instructions for items source coded to be manufactured or fabricated are found in WP 0051 00, Illustrated List of Manufactured Items.

Detailed assembly instructions for items source coded to be assembled from component spare/repair parts are found in this manual. Items that make up the assembly are listed immediately following the assembled item entry.

Line item entries for repair part kits and sets appear as the last entries in the repair part listing for the figure in which their parts are listed as repair parts.

Index Numbers. Items which have the word BULK in the figure column will have an index number shown in the item number column. This index number is a cross-reference between the NSN / P/N index work packages and the bulk material list in the repair parts list work package.

Illustrations List. The illustrations in this RPSTL contain unit authorized items. Illustrations published in this technical manual contain unit authorized items that appear in this RPSTL. The tabular list in the repair parts list work package contains only those parts coded "O" in the third position of the SMR code, therefore, there may be a break in the item number sequence.

HOW TO LOCATE REPAIR PARTS

1. When NSNs or P/Ns Are Not known.

First. Using the table of contents, determine the assembly group to which the item belongs. This is necessary since figures are prepared for assembly groups and subassembly groups, and lists are divided into the same groups.

Second. Find the figure covering the functional group or subfunctional group to which the item belongs.

Third. Identify the item on the figure and note the number(s).

Fourth. Look in the repair parts list work packages for the figure and item numbers. The NSNs and part numbers are on the same line as the associated item numbers.

2. When NSN is Known.

First, if you have the NSN, look in the STOCK NUMBER column of the NSN index work package. The NSN is arranged in NIIN sequence. Note the figure and item number next to the NSN.

Second. Turn to the figure and locate the item number. Verify that the item is the one you are looking for.

3. When P/N is Known.

First. If you have the P/N and not the NSN, look in the PART NUMBER column of the P/N index work package. Identify the figure and item number.

Second. Look up the item on the figure in the applicable repair parts list work package.

ANCILLARY EQUIPMENT FOR PERSONNEL TROOP PARACHUTE SYSTEM
EXTENSION, STATIC LINE, STANDARD, 5-FOOT

REPAIR PARTS LIST

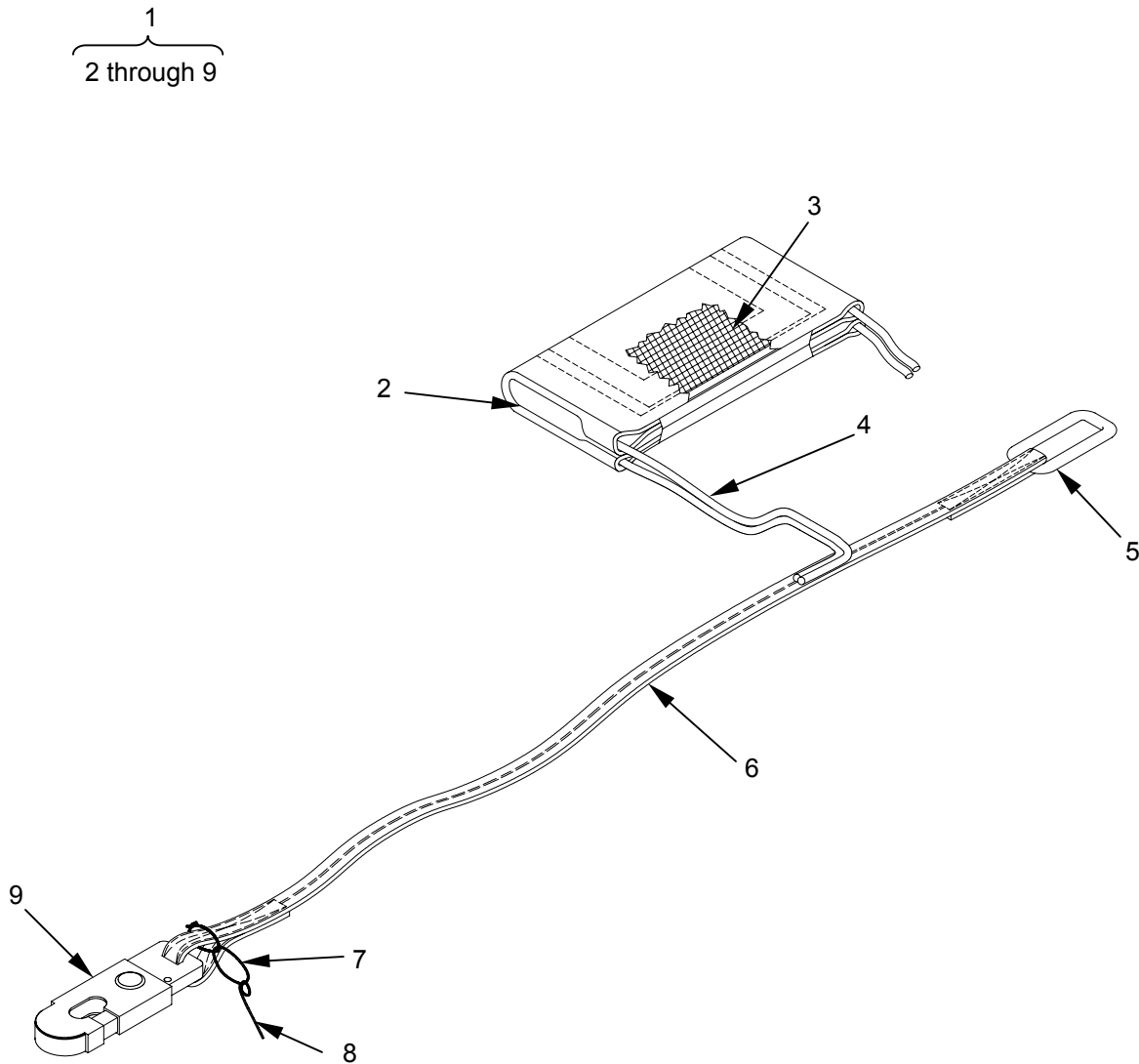

Fig 1. EXTENSION, STATIC LINE

(1)	(2)	(3)	(4)	(5)	(6)	(7)
ITEM NO	SMR CODE	NATIONAL STOCK NUMBER	CAGEC	PART NUMBER	DESCRIPTION AND USABLE ON CODE (UOC)	QTY
					GROUP 01 EXTENSION, STATIC LINE, STANDARD, 5-FOOT	
					FIG. 1 EXTENSION, STATIC LINE, STANDARD, 5-FOOT	
1	PBOOO	1670-00-368-4225	98750	53D6887	Extension, Static Line, Standard.....	1
2	XAOZZ		98750	53D6887-3	.Cover	1
3	XAOZZ		98750	53D6887-4	.Pad	1
4	XAOZZ		98750	53D6887-2	.Cord, Retaining.....	1
5	PAOZZ	1670-01-077-0744	96906	MS70108-1	.Link, Parachute.....	1
6	XAOZZ		98750	53D6887-1	.Static Line.....	1
7	XAOZZ		98750	53D6887-5	.Lanyard.....	1
8	PAOZZ	9509-00-892-4616	81346	ASTM-A580	.Wire, Safety, .08-inch dia., Type 430.....	1
9	PAOZZ	5340-00-491-1065	96906	MS70120	.Snap Hook.....	1
					END OF FIGURE	

ANCILLARY EQUIPMENT FOR PERSONNEL TROOP PARACHUTE SYSTEM

ACCESSORY SET, SCUBA

REPAIR PARTS LIST

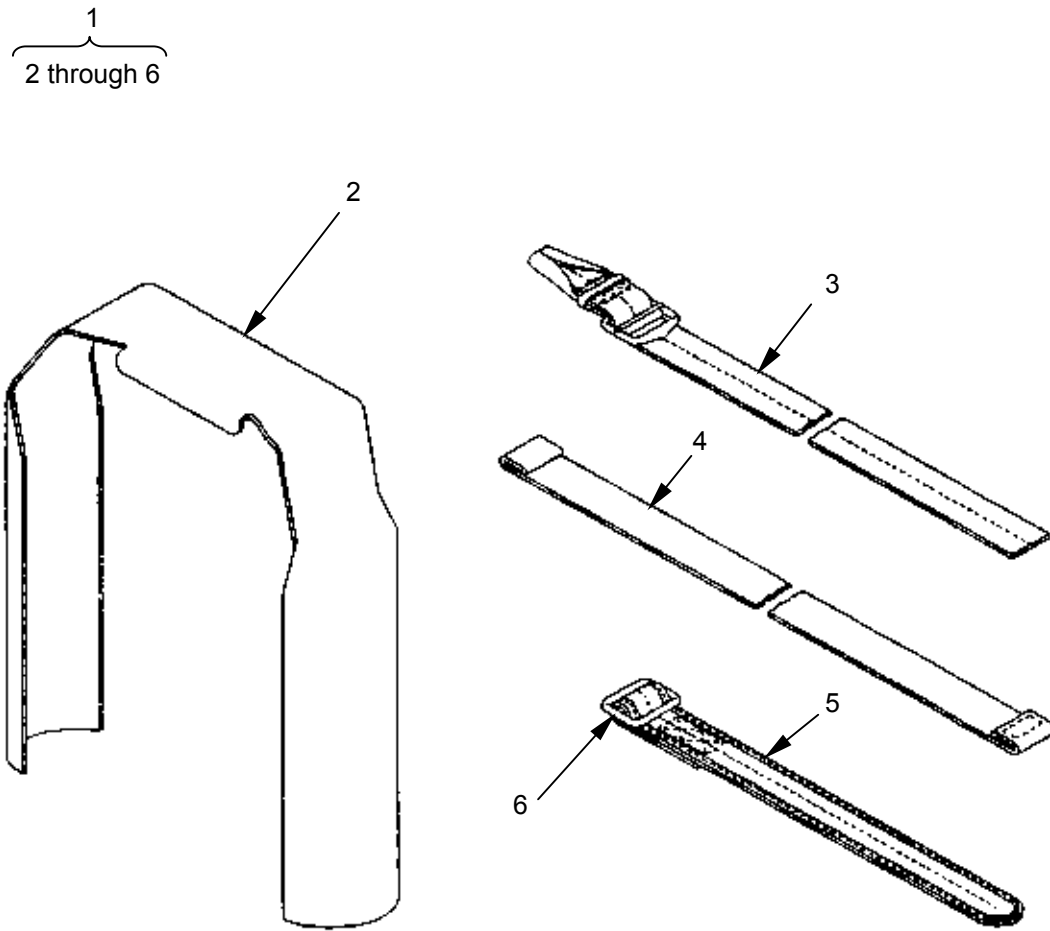

Fig 2. ACCESSORY SET, SCUBA

(1)	(2)	(3)	(4)	(5)	(6)	(7)
ITEM NO	SMR CODE	NATIONAL STOCK NUMBER	CAGEC	PART NUMBER	DESCRIPTION AND USABLE ON CODE (UOC)	QTY
					GROUP 02 ACCESSORY SET, SCUBA	
					FIG. 2 ACCESSORY SET, SCUBA	
1	PAOOO	1670-00-064-5735	81337	11-1-308	Accessory Set, Scuba.....	1
2	XAOZZ		81337	11-1-308-2	.Shield.....	1
3	MOOZZ		81337	11-1-308-1	.Strap, Support	1
4	MOOZZ		81337	11-1-308-3	.Backstrap, Harness	1
5	MOOZZ		81337	11-1-308-4	.Strap, Waistband Extension	1
6	PAOZZ	5340-00-360-0235	96906	MS22014-3	..Buckle.....	1
					END OF FIGURE	

ANCILLARY EQUIPMENT FOR PERSONNEL TROOP PARACHUTE SYSTEM

LINE, LOWERING, 15-FOOT

REPAIR PARTS LIST

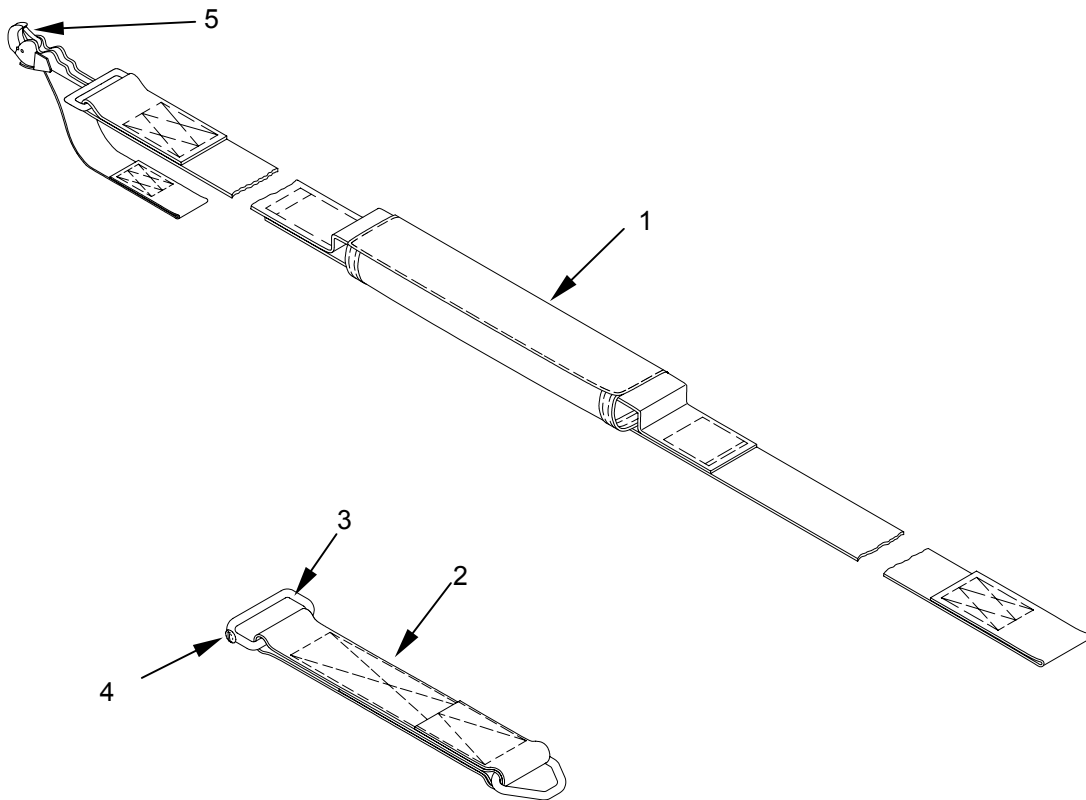

Fig 3. LOWERING LINE, 15-FOOT

(1)	(2)	(3)	(4)	(5)	(6)	(7)
ITEM NO	SMR CODE	NATIONAL STOCK NUMBER	CAGEC	PART NUMBER	DESCRIPTION AND USABLE ON CODE (UOC)	QTY
					GROUP 03 LOWERING LINE, 15-FOOT	
					FIG. 3 LOWERING LINE, 15-FOOT	
1	PAOOO	1670-01-067-6838	81337	11-1-2530-1	Lowering Line, 15-Foot.....	1
2	PAOZZ	1670-01-065-8196	81337	11-1-2721	. Adapter, Web, Lowering Line	1
3	PAOZZ	1670-00-217-2421	96906	MS22002-1	. . Link, Parachute Connector	1
4	PAOZZ	1670-01-263-4387	96906	MS22002-7	...Set Screw.....	2
5	PAOZZ	5340-00-887-2150	96906	MS22017	. Snap, Parachute Harness.....	1
					END OF FIGURE	

ANCILLARY EQUIPMENT FOR PERSONNEL TROOP PARACHUTE SYSTEM

JUMP PACK, DRAGON MISSILE

REPAIR PARTS LIST

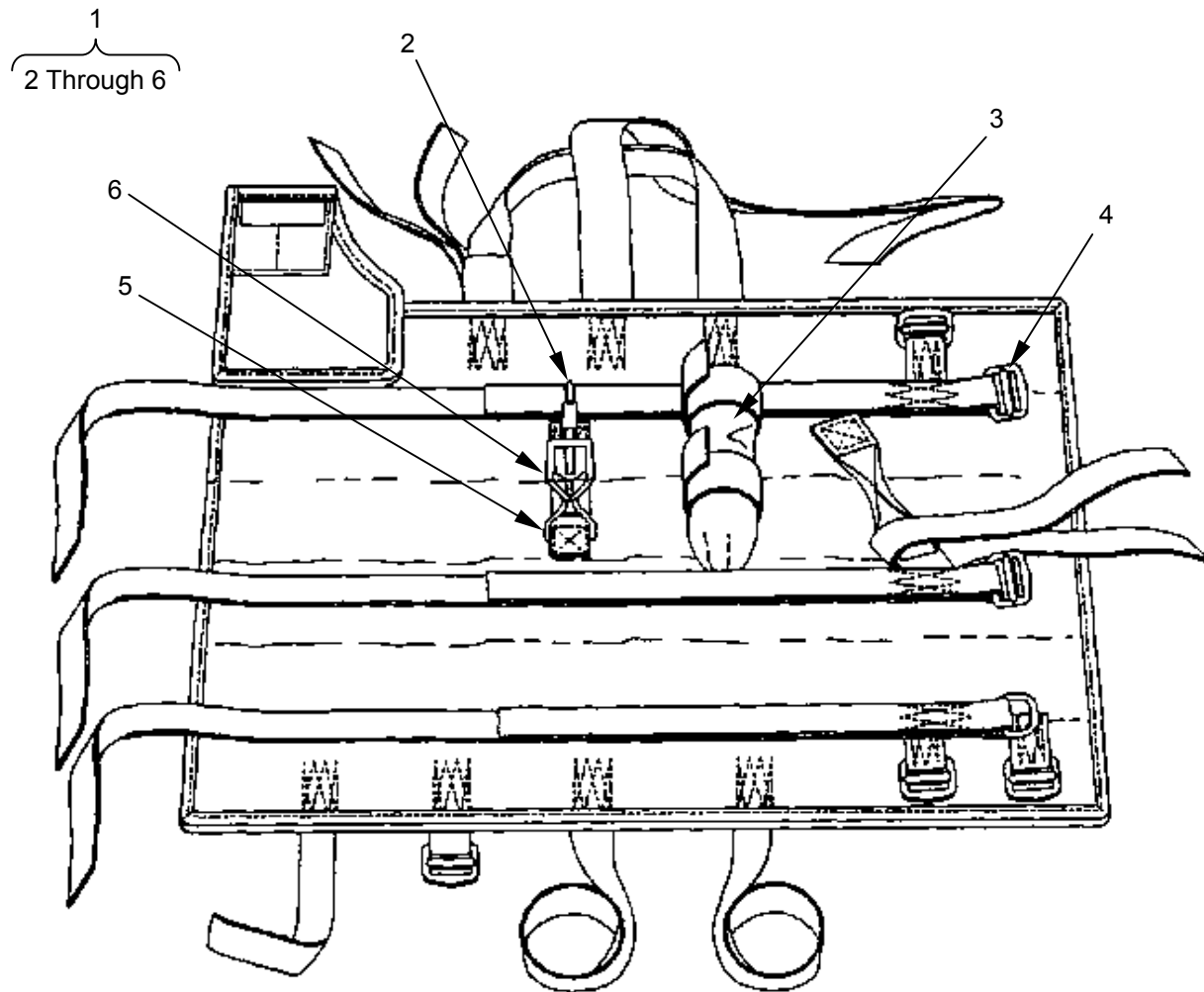

Fig 4. JUMP PACK, DRAGON MISSILE

(1)	(2)	(3)	(4)	(5)	(6)	(7)
ITEM NO	SMR CODE	NATIONAL STOCK NUMBER	CAGEC	PART NUMBER	DESCRIPTION AND USABLE ON CODE (UOC)	QTY
					GROUP 04 JUMP PACK, DRAGON MISSILE	
					FIG. 4 JUMP PACK, DRAGON MISSILE	
1	PAOOO	1670-01-035-7727	81337	11-1-2714	Jump Pack Dragon Missile	1
2	PAOZZ	5340-01-036-0473	96906	PS70099-1	.Snap Hook.....	1
3	MOOZZ		81337	11-1-2716	.Pocket Assembly, Lowering Line.....	1
4	PAOZZ	5340-01-050-7680	96906	MS70101-1	.Adapter, Special	7
5	PAOZZ	1670-00-360-0471	96906	MS22045-1	.Ring, Parachute Harness.....	1
6	PAOZZ	1670-01-079-9653	96906	MS70098	.Link, Quick Release.....	1
					END OF FIGURE	

ANCILLARY EQUIPMENT FOR PERSONNEL TROOP PARACHUTE SYSTEM

HARNESS, SINGLE POINT RELEASE

REPAIR PARTS LIST

- 1
2 Through 30
- 2
3 Through 16
- 17
18 Through 22
- 23
24 and 25
- 26
27 Through 29

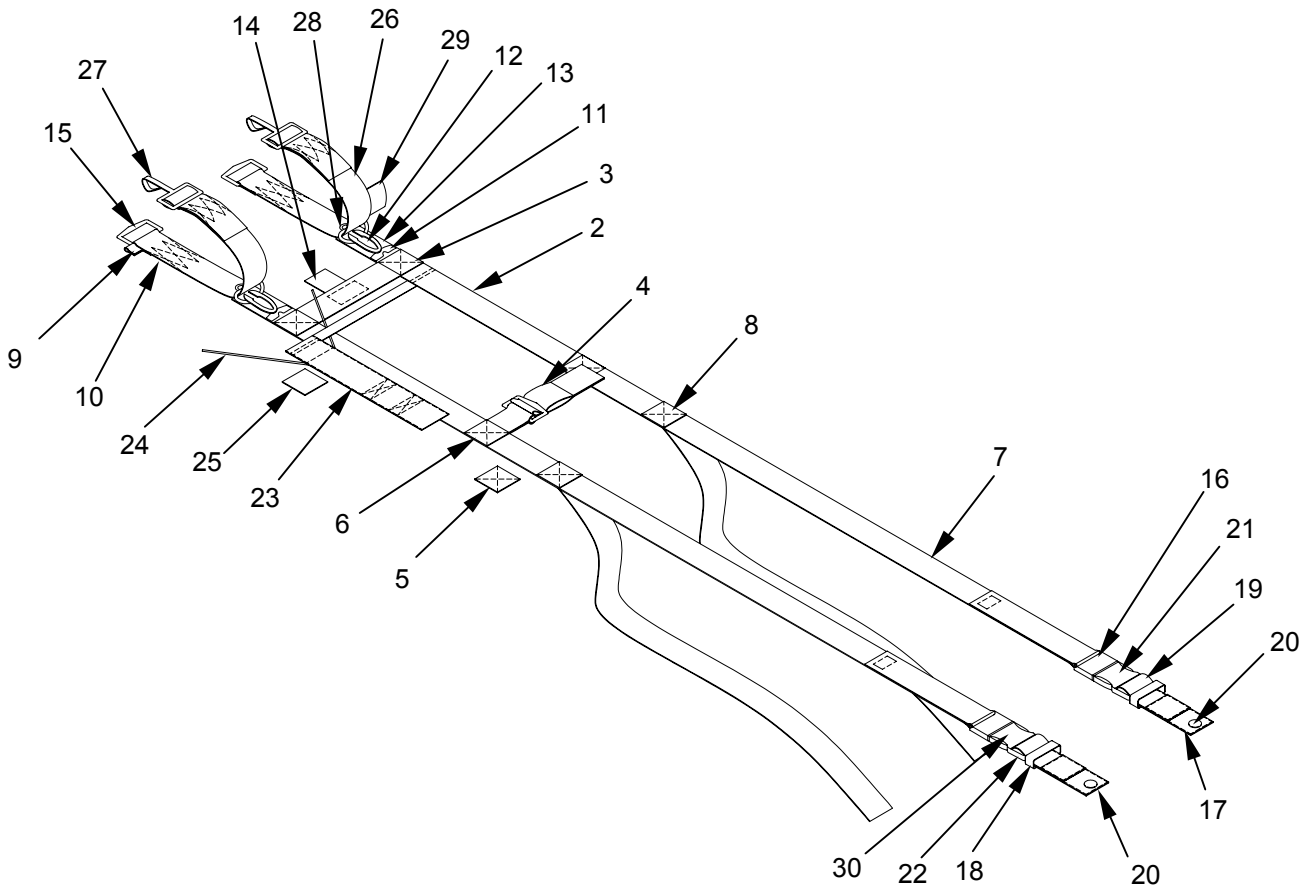

Fig 5. HARNESS, SINGLE POINT RELEASE

(1)	(2)	(3)	(4)	(5)	(6)	(7)
ITEM NO	SMR CODE	NATIONAL STOCK NUMBER	CAGEC	PART NUMBER	DESCRIPTION AND USABLE ON CODE (UOC)	QTY
					GROUP 05. HARNESSES, SINGLE POINT RELEASE	
					FIG. 5. HARNESSES, SINGLE POINT RELEASE	
1	PAOOO	1670-01-227-7792	81337	11-1-3008	Harness, Parachutist, Single Point Release	1
2	XAOOO		81337	11-1-3009	..Harness Assembly.....	1
3	MOOZZ		81337	11-1-3009-2	..Strap, Cross.....	1
4	MOOZZ		81337	11-1-3009-3	..Strap, Cross, Adjustable	1
5	XAOZZ		81337	11-1-3009-1	..Strap, Retainer	1
6	MOOZZ		81337	11-1-3009-4	...Adapter Chape.....	2
7	MOOZZ		81337	11-1-3009-5	..Strap, Leg.....	2
8	MOOZZ		81337	11-1-3009-6	..Keeper.....	2
9	MOOZZ		81337	11-1-3009-7	..Buffer	2
10	MOOZZ		81337	11-1-3012-1	..Web	2
11	MOOZZ		81337	11-1-3009-9	..Loop C.....	2
12	MOOZZ		81337	11-1-3009-10	..Loop B.....	2
13	MOOZZ		81337	11-1-3009-11	..Loop A.....	2
14	MOOZZ		81337	11-1-3009-12	..Fastener, Tape, Hook.....	1
15	PAOZZ	5340-01-050-7680	96906	MS70101-1	..Adapter, Special	2
16	XAOZZ		IES60	SR-2	..Buckle, Male.....	2
17	PAOZZ	1670-01-283-6412	81337	11-1-3010	..Strap, Leg Release.....	2
18	XAOZZ		81337	11-1-3010-2	..Keeper, Elastic	2
19	XAOZZ		81337	11-1-3010-3	..Loop, Web	2
20	PAOZZ	5325-01-028-0945	81337	5-4-1602-12-4	..Grommet, Metallic.....	2
21	XAOZZ		IES60	SR-2	..Buckle, Female.....	2
22	XAOZZ		81337	11-1-3010-7	..Buffer.....	2
23	PAOZO	5340-01-353-0637	81337	11-1-3011	..Lever, Manual Control	1
24	XAOZZ		81337	11-1-3011-2	..Wire Rope Jacket	1
25	MOOZZ		81337	11-1-3011-5	..Fastener, Tape, Pile	1
26	PAOZZ	5340-01-364-6335	81337	11-1-3012	..Strap, Harness Attaching.....	2
27	PAOZZ	5340-00-881-3038	96906	MS22043-1	..Snap Hook.....	2
28	PAOZZ	1670-00-862-5749	96906	MS22020-1	..Link, Parachute Harness	2
29	MOOZZ		81337	11-1-3012-4	..Buffer.....	2
30	PAOZZ	5340-01-097-8651	IES60	SR2	..Buckle, Male/Female	2
					END OF FIGURE	

ANCILLARY EQUIPMENT FOR PERSONNEL TROOP PARACHUTE SYSTEM

PACK, ASSEMBLY, AT4

REPAIR PARTS LIST

1
2 Through 9

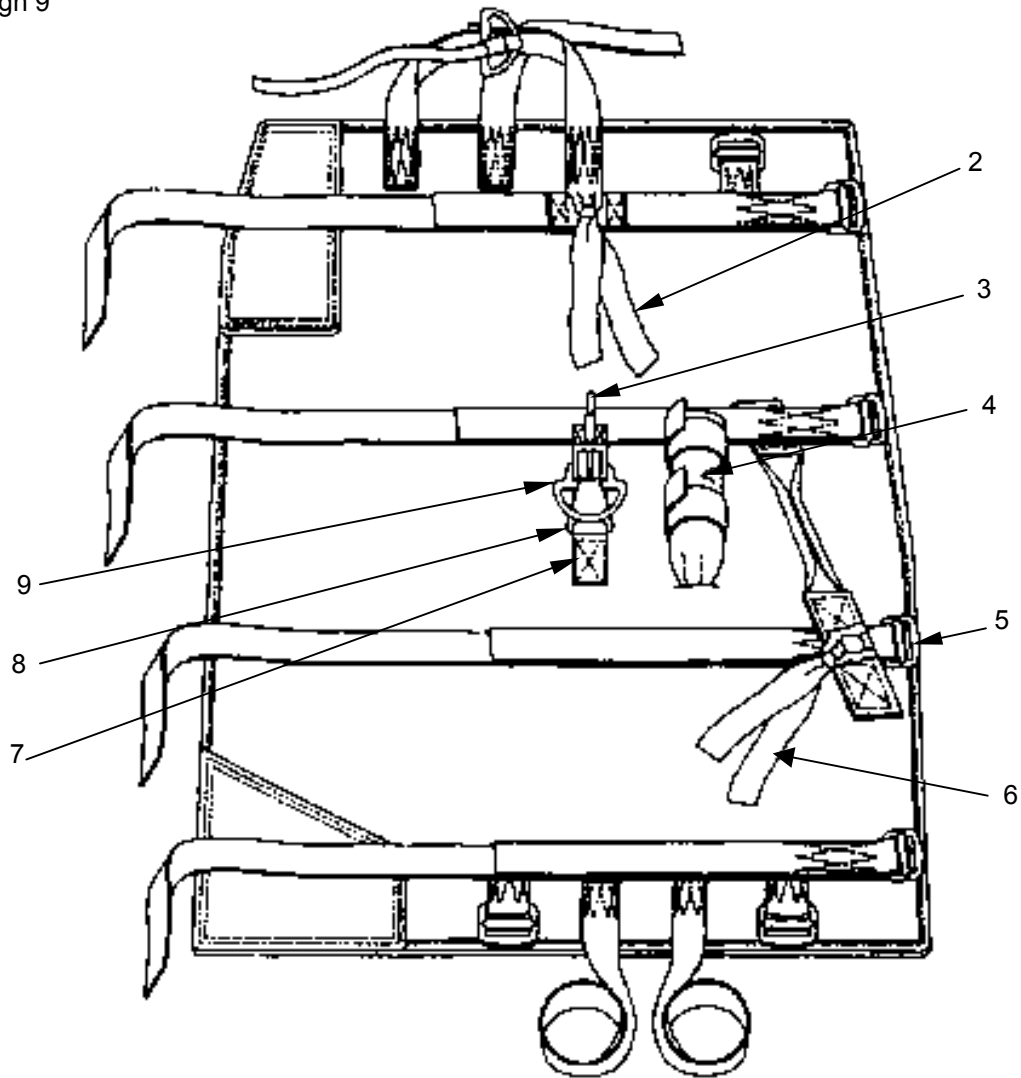

Fig 6. PACK, ASSEMBLY, AT4

(1)	(2)	(3)	(4)	(5)	(6)	(7)
ITEM NO	SMR CODE	NATIONAL STOCK NUMBER	CAGEC	PART NUMBER	DESCRIPTION AND USABLE ON CODE (UOC)	QTY
					GROUP 06 PACK, ASSEMBLY, AT4	
					FIG. 6 PACK, ASSEMBY, AT4	
1	PAOZZ	1670-01-259-5932	81337	11-1-3398	Pack, Assembly, AT4.....	1
2	MOOZZ		81337	11-1-3398-20	.Tiedown Upper	1
3	PAOZZ	5340-01-036-0473	96906	PS70099-1	.Snap Hook.....	1
4	MOOZZ		81337	11-1-3401	.Pocket Assembly, Lowering.....	1
5	PAOZZ	5340-01-050-7680	96906	MS70101-1	.Adapter, Special	7
6	MOOZZ		81337	11-1-3398-21	.Tiedown Leg	1
7	MOOZZ		81337	11-1-3403	.Forward End Cross Strap	1
8	PAOZZ	1670-01-079-9653	96906	MS70098	.Link, Quick Release.....	1
9	PAOZZ	5365-01-278-0418	81337	11-1-485	.Ring, D.....	2
					END OF FIGURE	

ANCILLARY EQUIPMENT FOR PERSONNEL TROOP PARACHUTE SYSTEM

CASE, PARACHUTIST'S INDIVIDUAL WEAPON, M-1950, COTTON

REPAIR PARTS LIST

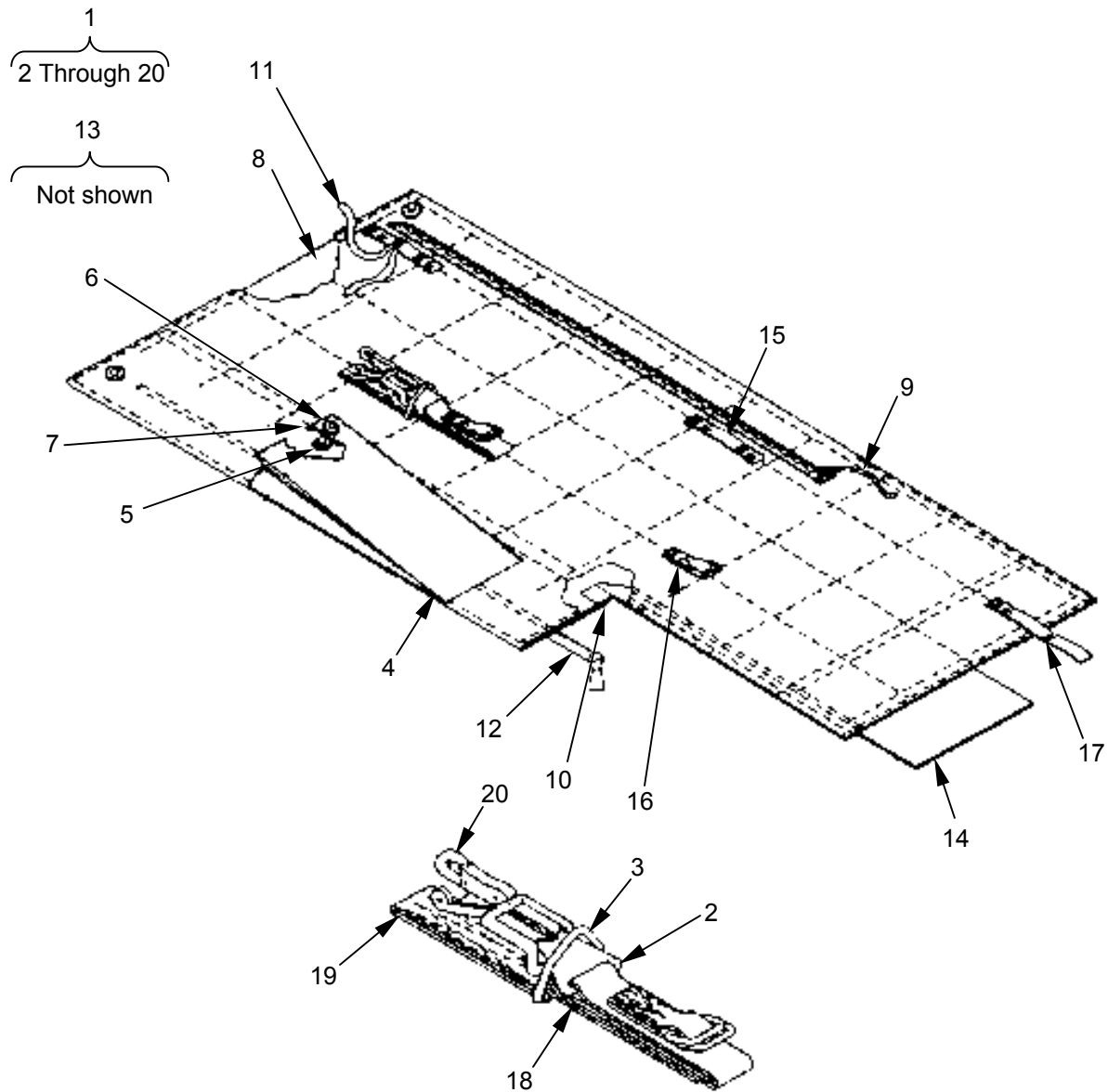

Fig 7. CASE, PARACHUTIST'S INDIVIDUAL WEAPON, M-1950, COTTON

(1)	(2)	(3)	(4)	(5)	(6)	(7)
ITEM NO	SMR CODE	NATIONAL STOCK NUMBER	CAGEC	PART NUMBER	DESCRIPTION AND USABLE ON CODE (UOC)	QTY
					GROUP 07 CASE, PARACHUTIST'S INDIVIDUAL WEAPON, M-1950, COTTON	
					FIG. 7 CASE, PARACHUTIST'S INDIVIDUAL WEAPON, M-1950, COTTON	
1	PAOZZ	8465-00-261-4995	81349	MIL-C-10922	Case, Parachutist's Individual Weapon, M-1950, Cotton	1
2	PAOZZ	1670-01-079-9653	96906	MS70098	. Link, Quick Release	1
3	PAOZZ	1670-00-360-0471	96906	MS22045-1	. Ring, Parachute Harness	1
4	MOOZZ		81337	2-2-116-1	. Pocket, Lowering Line	2
5	PAOZZ	5325-01-356-2566	96906	MS27977-64B	. . Stud, Snap Fastener	1
6	PAOZZ	5325-00-281-4356	96906	MS27977-1B	. . Socket, Snap Fastener	1
7	PAOZZ	5325-00-276-4283	96906	MS27977-3B	. . Clinch Plate, Snap Fastener	1
8	MOOZZ		81337	2-2-116-2	. Panel, Strip	1
9	MOOZZ		81337	2-2-116-4	. Thong, Slide Fastener	1
10	MOOZZ		81337	2-2-116-5	. Reinforcement Corner	1
11	MOOZZ		81337	2-2-116-6	. Tape, Tiedown, Upper	1
12	MOOZZ		81337	2-2-116-9	. Thong, Flap	1
13	MOOZZ		81337	2-2-116-8	. Strap, Tiedown, Lower	1
14	MOOZZ		81337	2-2-116-10	. Reinforcement, Leather	1
15	MOOZZ		81337	2-2-116-11	. Loop Tiedown, Lower	2
16	MOOZZ		81337	2-2-116-12	. Loop, Chape	1
17	MOOZZ		81337	2-2-116-14	. Strap, Adjustable	1
18	MOOZZ		81337	2-2-116-20	. Loop, Chape, Triangular	1
19	MOOZZ		81337	2-2-116-18	. Loop, Chape, Single	1
20	PAOZZ	5340-01-036-0473	96906	MS70099	Snap Hook, Quick Release	1
					END OF FIGURE	

(1)	(2)	(3)	(4)	(5)	(6)	(7)
ITEM NO	SMR CODE	NATIONAL STOCK NUMBER	CAGEC	PART NUMBER	DESCRIPTION AND USABLE ON CODE (UOC)	QTY
					GROUP 08 CASE, PARACHUTIST'S INDIVIDUAL WEAPON, M-1950, NYLON	
					FIG. 8 CASE, PARACHUTIST'S INDIVIDUAL WEAPON, M-1950, NYLON	
1	PAOOZ	8465-01-109-0702	81349	MIL-C-10922	Case, Parachutist's Individual Weapon, M-1950	1
2	MOOZZ		81337	2-2-114-15	. Loop, Chape, Assembly.....	1
3	PAOZZ		81337	2-2-114-28	. . Loop, Chape, Single	1
4	MOOZZ	5340-01-036-0473	96906	PS70099-1	. . Snap Hook, Quick Release.....	1
5	PAOZZ	1670-00-360-0471	81337	MS22045-1	. . Ring, Parachute Harness.....	2
6	PAOZZ	1670-01-079-9653	96906	MS70098	. Link, Quick Release.....	1
7	PAOZZ	5325-00-281-4356	96906	MS27977-1B	. Socket, Snap Fastener	1
8	PAOZZ	5325-00-276-4283	81337	MS27977-3B	. Clinch Plate, Snap Fastener	1
9	PAOZZ		81337	2-2-627	. Felt, Backing	1
10	MOOZZ		81337	2-2-114-9	. Loop, Tiedown, Upper	1
11	MOOZZ	5325-00-785-8146	96906	MS27977-8B	. Stud, Snap Fastener.....	1
12	MOOZZ	5325-00-776-1219	96906	MS27977-10B	. Washer, Snap Fastener.....	1
13	MOOZZ		81337	2-2-114-8	. Strap, Tiedown, Upper.....	1
14	MOOZZ		81337	2-2-114-10	. Slide Fastener	1
15	MOOZZ		81337	2-2-632	. Webbing, Lower Tiedown	1
16	MOOZZ		81337	2-2-114-23	. Thong, Slide Fastener	1
17	MOOZZ		81337	2-2-114-6	. Protective Cover	1
18	MOOZZ		81337	2-2-114-7	. Strap, Adjustable	1
19	MOOZZ		81337	2-2-628	. Reinforcement Webbing	1
20	MOOZZ		81337	2-2-114-11	. Loop, Chape	1
21	MOOZZ		81337	2-2-114-13	. Reinforcement Corner	1
22	MOOZZ		96906	2-2-269	. Pocket, Lowering Line	1
					END OF FIGURE	

ANCILLARY EQUIPMENT FOR PERSONNEL TROOP PARACHUTE SYSTEM
PARACHUTIST'S WEAPONS AND INDIVIDUAL EQUIPMENT PACK AND HARNESS ASSEMBLY

REPAIR PARTS LIST

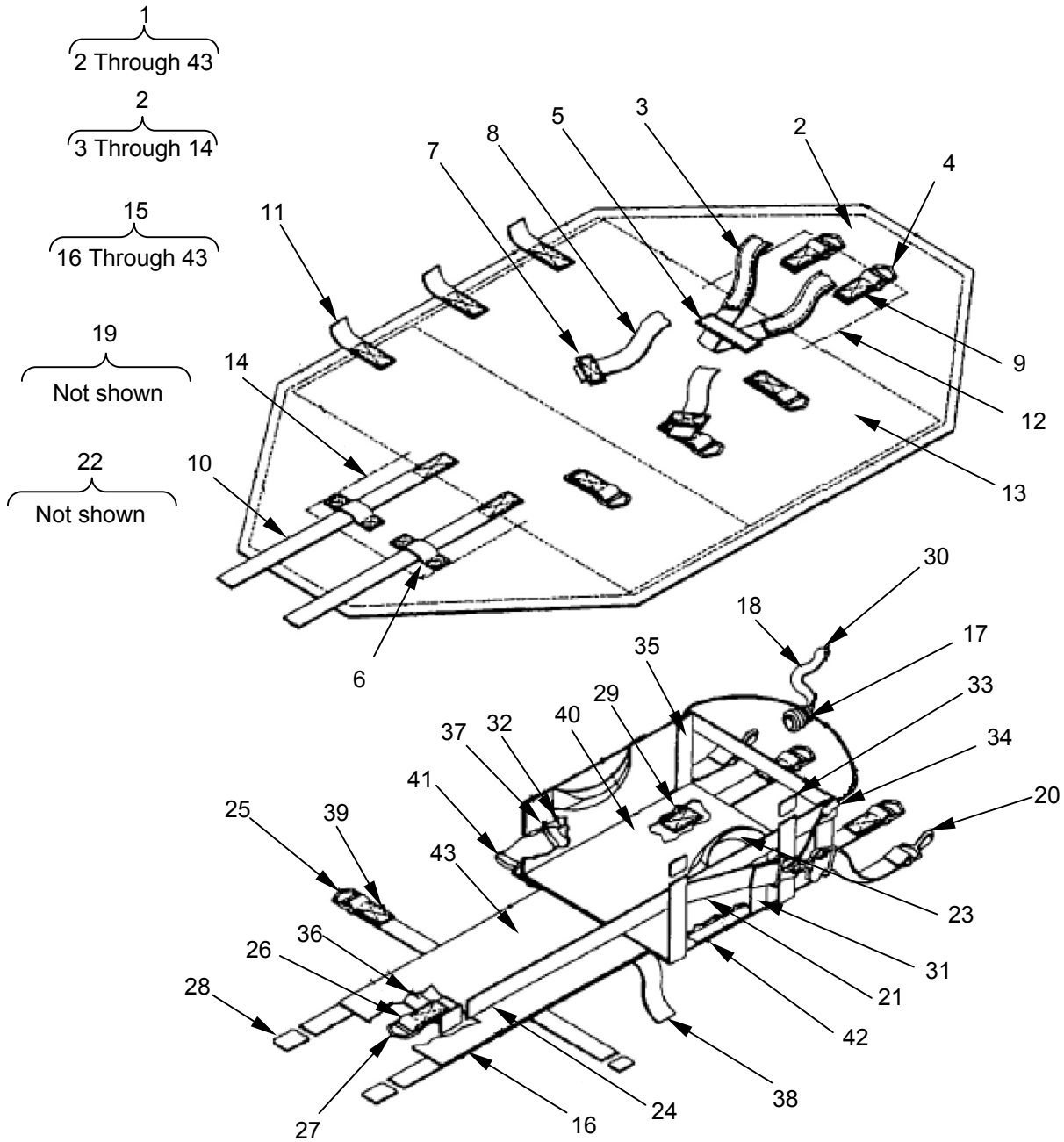

Fig 9. PARACHUTIST'S WEAPONS AND INDIVIDUAL EQUIPMENT PACK AND HARNESS ASSEMBLY

(1)	(2)	(3)	(4)	(5)	(6)	(7)
ITEM NO	SMR CODE	NATIONAL STOCK NUMBER	CAGEC	PART NUMBER	DESCRIPTION AND USABLE ON CODE (UOC)	QTY
					GROUP 09 PARACHUTIST'S WEAPONS AND INDIVIDUAL EQUIPMENT PACK AND HARNES ASSEMBLY	
					FIG. 9 PARACHUTIST'S WEAPONS AND INDIVIDUAL EQUIPMENT PACK AND HARNES ASSEMBLY	
1	PAOOO	8465-00-753-6549	81349	MIL-P-43304	Pack and Harness Assembly.....	1
2	PAOOO	8465-00-753-6547	81337	5-4-693	. Pack Assembly.....	2
3	MOOZZ		81337	5-4-693-2-1	. . Suspender A Assembly.....	1
4	PAOZZ	5340-01-050-7680	81337	MS70101-1	. . Adapter, Special.....	1
5	MOOZZ		81337	5-4-693-2-4	. . Tape, Reinforcement.....	1
6	MOOZZ		96906	5-4-693-2-5	. . Strap Guide.....	1
7	MOOZZ		81337	5-4-693-2-6	. . Reinforcement Band.....	1
8	MOOZZ		81337	5-4-693-2-7	. . Suspender Lower.....	2
9	MOOZZ		81337	5-4-693-2-13	. Adapter and Chape.....	1
10	MOOZZ		81337	5-4-693-2-14	. . Web Strap.....	2
11	MOOZZ		81337	5-4-693-2-15	. . Web Strap.....	2
12	XDOZZ		81337	5-4-693-2-9	. . Pad.....	1
13	XDOZZ		81337	5-4-693-2-16	. . Pad.....	3
14	XAOZZ		96906	5-4-693-2-17	. . Pad.....	2
15	PAOZO	8465-00-753-6548	81349	MIL-P-43304	. Harness, Parachutist's.....	1
16	XAOZZ		81337	5-4-697-3-1	. . Harness Body.....	1
17	XCOZZ		81337	MIL-R-45906	. . Release Assembly.....	1
18	MOOZZ		81337	5-4-697-3-3	. . Release Strap.....	2
19	MBOZZ		81337	5-4-697-3-5	. . Keeper.....	2
20	PAOZZ	5340-01-023-9442	81337	11-1-2501	. . Snap Hook.....	1
21	MOOZZ		81349	5-4-697-3-13	. . Strap A, Side.....	1
22	MOOZZ		81337	5-4-697-3-14	. . Buffer.....	1
23	MOOZZ		81337	5-4-697-3-15	. . Handle.....	2
24	MOOZZ		81337	5-4-697-3-22	. . Handle, Strap.....	1
25	PAOZZ	5340-01-050-7680	81337	MS70101-1	. . Adapter, Special.....	1
26	MOOZZ		81337	5-4-697-3-24	. . Strap, Upper Suspension.....	1
27	XAOZZ		81337	MS220454	. . V-Ring.....	1
28	MOOZZ		81337	5-4-697-3-26	. . Lower Suspension Strap.....	1
29	MOOZZ		81337	5-4-697-3-27	. . Strap, F Reinforcement.....	2
30	XBOZZ		81337	5-4-697-3-28	. . Strap, Keeper Pin.....	2
31	MOOZZ		81337	5-4-697-3-30	. . Body Reinforcement.....	1
32	MOOZZ		96906	5-4-697-3-31	. . Pocket Flap.....	1

(1)	(2)	(3)	(4)	(5)	(6)	(7)
ITEM NO	SMR CODE	NATIONAL STOCK NUMBER	CAGEC	PART NUMBER	DESCRIPTION AND USABLE ON CODE (UOC)	QTY
33	MOOZZ		81337	5-4-697-3-34	. . Strap	2
34	MOOZZ		81337	5-4-697-3-35	. . Retaining Loop	2
35	MOOZZ		81337	5-4-697-3-36	. . Reinforcement 4	1
36	MOOZZ		81337	5-4-697-3-37	. . Reinforcement K	1
37	MOOZZ		81337	5-4-697-3-38	. . Tie Tape	1
38	MOOZZ		81337	5-4-697-3-39	. . Leg Strap	2
39	MOOZZ		81337	5-4-697-3-40	. . Strap L Adapter	2
40	MOOZZ		81337	5-4-697-3-41	. . Body M Reinforcement	1
41	MOOZZ		81337	5-4-697-3-42	. . Pocket.....	1
42	MOOZZ		81337	5-4-697-3-43	. . Leg Strap Guide	2
43	MOOZZ		81337	5-4-697-3-44	. . Body Piece	2
END OF FIGURE						

ANCILLARY EQUIPMENT FOR PERSONNEL TROOP PARACHUTE SYSTEM

JUMP PACK, STINGER MISSILE

REPAIR PARTS LIST

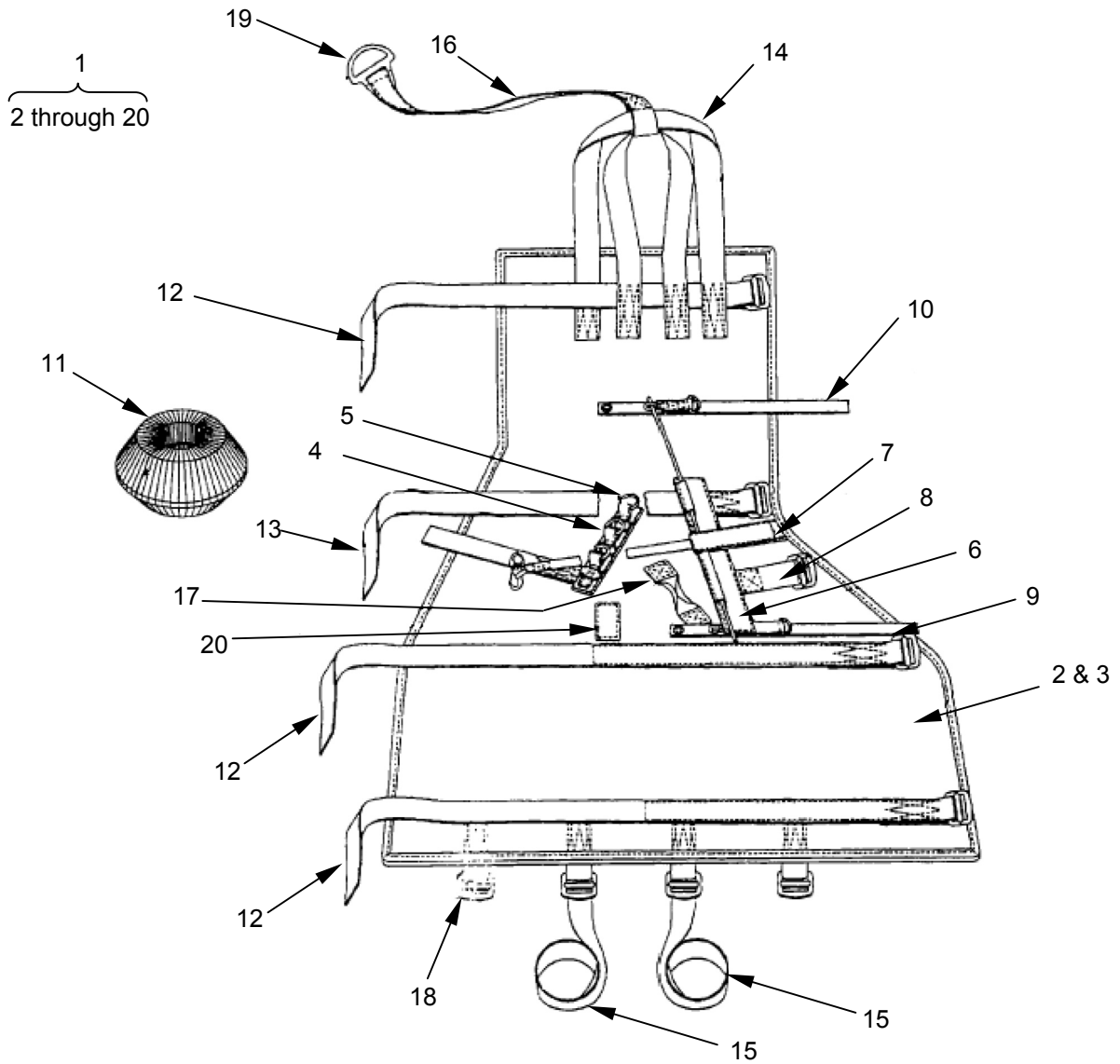

Fig 10. JUMP PACK, STINGER MISSILE

(1)	(2)	(3)	(4)	(5)	(6)	(7)
ITEM NO	SMR CODE	NATIONAL STOCK NUMBER	CAGEC	PART NUMBER	DESCRIPTION AND USABLE ON CODE (UOC)	QTY
					GROUP 10 JUMP PACK, STINGER MISSILE	
					FIG. 10 JUMP PACK, STINGER MISSILE	
1	PAOOO	1670-01-352-9264	81337	11-1-3890	Jump Pack, Stinger Missile.....	1
2	XAOZZ		81337	11-1-3891-1	. Shell, Nylon	1
3	XAOZZ		81337	11-1-3891-2	. . Liner, Felt.....	1
4	XAOZZ		81337	11-1-3893-1	. Strap, Ring.....	1
5	XDOZZ	5365-00-202-0228	96906	MS51925-2	. . Ring, D Medium	3
6	MOOZZ		81337	11-1-3894-1	. Strap, Cable Guide	1
7	PAOZZ		81337	11-1-3895-1	. Quick-Release	1
8	MOOZZ		81337	11-1-3890-6	. Strap, Quick Release.....	1
9	MOOZZ		81337	11-1-3898-1	. Tie-Down, Leg	1
10	MOOZZ		81337	11-1-3898-2	. Tie-Down, Chest.....	1
11	PAOZZ		81337	11-1-3896-1	. End Cap, Foam	2
12	MOOZZ		81337	11-1-3890-10	. Strap/Suspender Quick-Release	3
13	MOOZZ		81337	11-1-3890-11	. Strap, Closing	1
14	MOOZZ		81337	11-1-3890-12	. Strap, Riser.....	2
15	MOOZZ		81337	11-1-3890-13	. Strap, Securing	2
16	MOOZZ		81337	11-1-3890-14	. Strap, Lowering	1
17	MOOZZ		81337	11-1-3890-15	. Strap, Carrying	1
18	MOOZZ		81337	11-1-3890-16	. Strap, Attaching, Quick Release.....	2
19	PAOZZ	5365-01-278-0418	81337	11-1-485	. Ring, D.....	1
20	MOOZZ		81337	11-1-3890-21	. Fastener, Pile	1
					END OF FIGURE	

ANCILLARY EQUIPMENT FOR PERSONNEL TROOP PARACHUTE SYSTEM
RELEASE, PARACHUTIST'S, INDIVIDUAL EQUIPMENT
REPAIR PARTS LIST

1
2 through 9

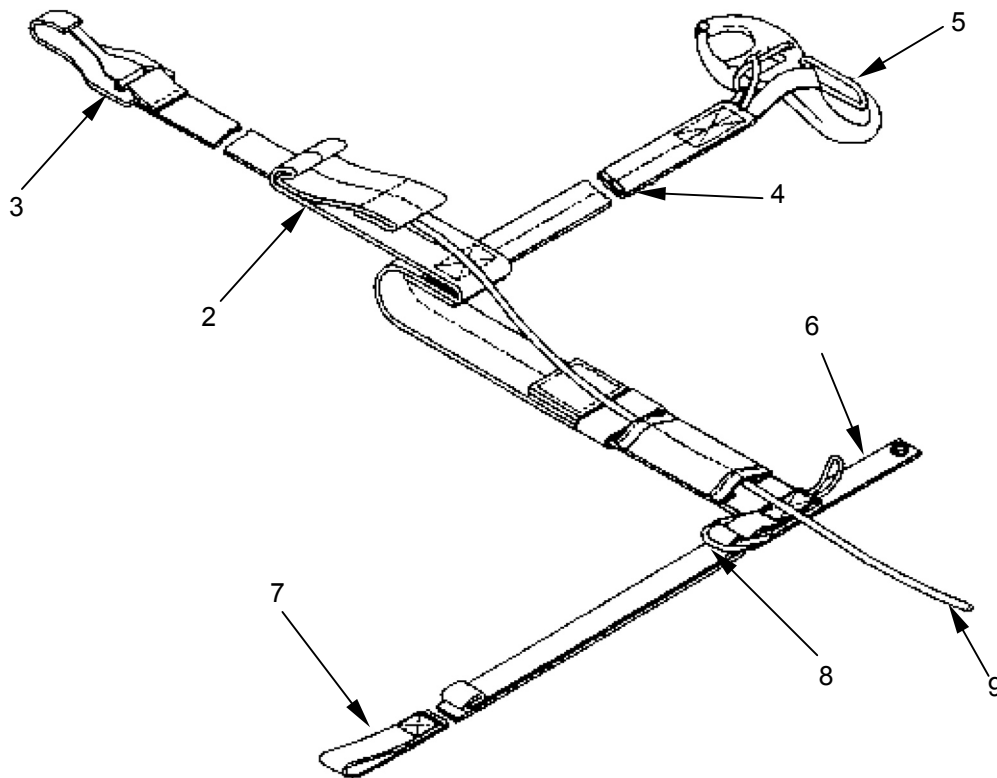

Fig 11. RELEASE, PARACHUTIST'S, INDIVIDUAL EQUIPMENT

(1)	(2)	(3)	(4)	(5)	(6)	(7)
ITEM NO	SMR CODE	NATIONAL STOCK NUMBER	CAGEC	PART NUMBER	DESCRIPTION AND USABLE ON CODE (UOC)	QTY
					GROUP 11 RELEASE, PARACHUTIST'S, INDIVIDUAL EQUIPMENT	
					FIG. 11 RELEASE, PARACHUTIST'S, INDIVIDUAL EQUIPMENT	
1	PAOOO	1670-01-415-0035	81337	11-1-6860-1	Release Assembly, AIRPAC.....	1
2	XAOZZ		81337	11-1-6863-1	. Cable Release Assembly.....	1
3	XBOOO		81349	M43770/10- CCBC1	. . Snap Hook, Cast Body	1
4	XAOOO		81337	11-1-6864-1	. Quick Release Assembly.....	1
5	XBOZZ		81337	11-1-3901-1	. . Shackle, Snap, w/Snap Hook.	1
6	XAOZZ		81337	11-1-6862-1	. Release Assembly, Upper Attachment	1
7	XAOZZ		81337	11-1-6865-1	. . Strap, Upper Attachment	1
8	XBOOO		81349	MIL-R-3390	. . Ring, D, Style 1, Class 1, 1-in X 7/8-in H.....	12
9	PAOZZ	4010-00-618-4717	81337	M83420/3-002	. . Wire, Rope, Flexible, Type II (Jacketed) Comp A.	A/R
					END OF FIGURE	

ANCILLARY EQUIPMENT FOR PERSONNEL TROOP PARACHUTE SYSTEM

CONTAINER, FRONT MOUNT

REPAIR PARTS LIST

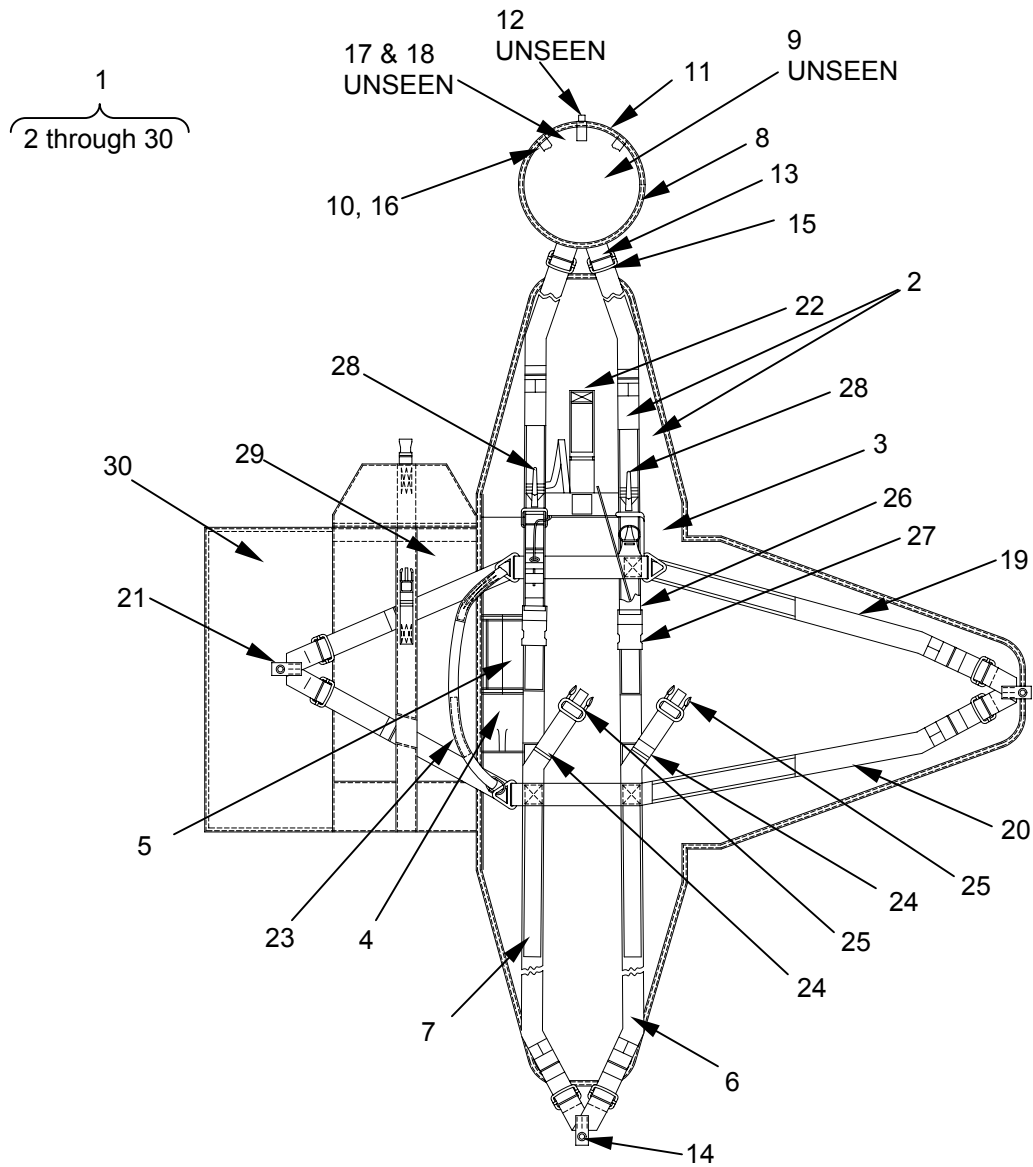

Fig 12. CONTAINER, FRONT MOUNT

(1)	(2)	(3)	(4)	(5)	(6)	(7)
ITEM NO	SMR CODE	NATIONAL STOCK NUMBER	CAGEC	PART NUMBER	DESCRIPTION AND USABLE ON CODE (UOC)	QTY
					GROUP 12 CONTAINER, FRONT MOUNT	
					FIG. 12 CONTAINER, FRONT MOUNT	
1	PAOZZ	1670-01-413-7836	81337	11-1-6832	Container, Front Mount.....	1
2	XAOOO		81337	11-1-6833	Harness and Body Assembly.....	1
3	XAOZZ		81337	11-1-6836-1	. Body Assembly, Container	1
4	XAOZZ		81337	11-1-6847-1	. Pocket, Lowering Line	1
5	XAOZZ		81337	11-1-6845-1	. Closure Flap, Lowering Line	1
6	XAOOO		81337	11-1-6837	. Restraint Assembly, Vertical.....	1
7	XAOZZ		81337	11-1-6848-2	. . Strap, Reinforcement, 86-Inch.....	2
8	XAOOO		81337	11-1-6850	. . Closing Flap Assembly	1
9	XAOOO		81337	11-1-6855FD1	...Flap.	1
10	MOOZZ		81337	11-1-6855FD2	...Fastener, Hook	3
11	XAOZZ		81337	11-1-6855FD3	...Reinforcement, Edge	1
12	MOOZZ		81337	11-1-6854-1	...Loop Assembly, Restraint	1
13	XAOZZ		81337	11-1-6854FD1	...Strap, Nylon	1
14	XAOZZ		81337	11-1-6854FD2	...Loop, Cord, TY I, 8-Inch.....	1
15	XAOZZ		81337	11-1-6854FD3	...Adapter, Quick Fit	2
16	XAOZZ		81337	11-1-6857FD2	...Fastener, Pile.....	3
17	XAOZZ		81337	11-1-6857FD4	...Strap, Locking Pin.....	1
18	XAOZZ		81337	11-1-6856	...Pin, Locking	1
19	XAOZZ		81337	11-1-6838	...Restraint Assembly, Horizontal	1
20	XAOZZ		81337	11-1-6848-1	...Strap, Assembly.....	2
21	XAOZZ		81337	11-1-6849FD1	. . Tab, Closing	3
22	XAOOO		81337	11-1-6844	. . Release, Handle	1
23	XAOZZ		81337	11-1-6841	. . Bridle	1
24	XAOOO		81337	11-1-6842	. . Strap, Leg.....	2
25	XAOZZ		81337	5-4-7605M	. . Side Release, Male.....	2
26	XAOOO		81337	11-1-6842	. . Release, Strap, Leg.....	2
27	XAOZZ		81337	5-4-7605F	...Side Release, Female.....	2
28	XAOZZ		81337	11-1-6840	. . Strap, Attaching	2
29	XAOZZ		81337	11-1-6834	. . Container, Side.....	1
30	XAOOO		81337	11-1-6835	Kit Bag, Internal.....	1
					END OF FIGURE	

ANCILLARY EQUIPMENT FOR PERSONNEL TROOP PARACHUTE SYSTEM

CONTAINER, SIDE MOUNT

REPAIR PARTS LIST

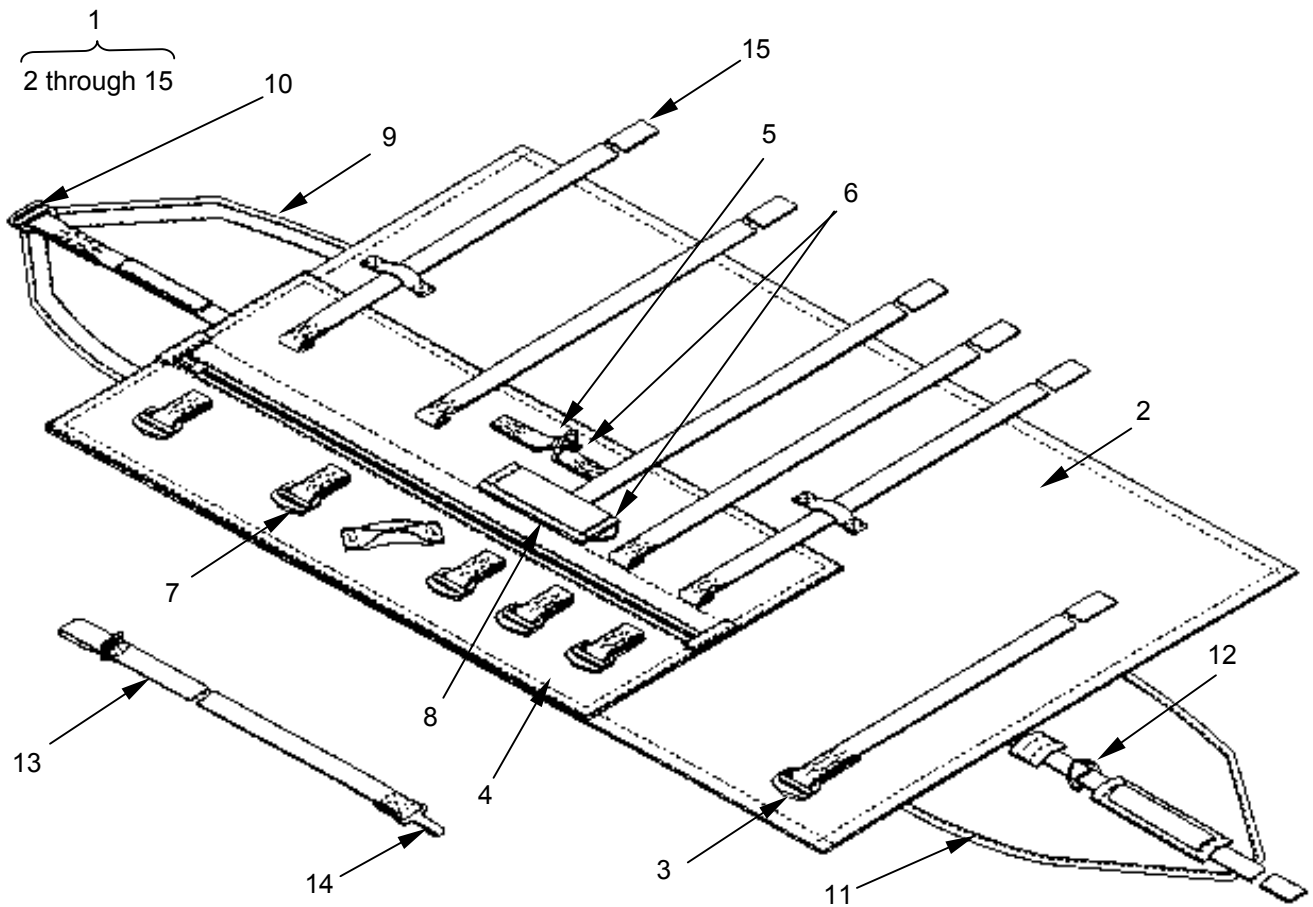

Fig 13. CONTAINER, SIDE MOUNT

(1)	(2)	(3)	(4)	(5)	(6)	(7)
ITEM NO	SMR CODE	NATIONAL STOCK NUMBER	CAGEC	PART NUMBER	DESCRIPTION AND USABLE ON CODE (UOC)	QTY
					GROUP 13 CONTAINER, SIDE MOUNT	
					FIG. 13 CONTAINER, SIDE MOUNT	
1	PAOOO	1670-01-414-2757	81337	11-1-6866	Container, Side Mount	1
2	XAOZZ		81337	11-1-6867	. Cover Assembly, Outer	1
3	PAOZZ	5340-01-050-7680	81337	MS70101-1	. . Adapter, Reversible, Quick Fit	1
4	XAOZZ		81337	11-1-6868	. Padded Assembly, Outer	1
5	PAOZZ	1670-01-079-9653	81337	MS70098-1	. . Link, Snap, Quick Release, 1-3/4 Inches	1
6	PAOZZ	1670-00-360-0471	96906	MS22045-1	. . Ring, Parachute Harness "V"	2
7	PAOZZ	5340-01-050-7680	81337	MS70101-1	. . Adapter, Reversible, Quick Fit	5
8	XAOZZ		81337	11-1-6880	. . Rap Assembly, Lowering Line	1
9	MOOZZ		81337	11-1-6870	. Cap Assembly, Lower	1
10	PAOZZ	1670-00-884-3668	81337	MS22040-1	. . Adapter, Parachute Harness	1
11	MOOZZ		81337	11-1-6871	. Cap Assembly, Upper	1
12	MOOZZ	1670-00-360-0471	81337	MS22045-1	. . Ring, Parachute Harness "V"	2
13	PAOZZ		81337	11-1-6839	. Bridle Assembly, Lowering Harness	1
14	MOOZZ		81337	11-1-2501	. . Snap Hook, Parachute Harness	1
15	MOOZZ		81337	U/O #4	. . Strap, Securing	5
					END OF FIGURE	

ANCILLARY EQUIPMENT FOR PERSONNEL TROOP PARACHUTE SYSTEM

PARACHUTE DROP BAG

REPAIR PARTS LIST

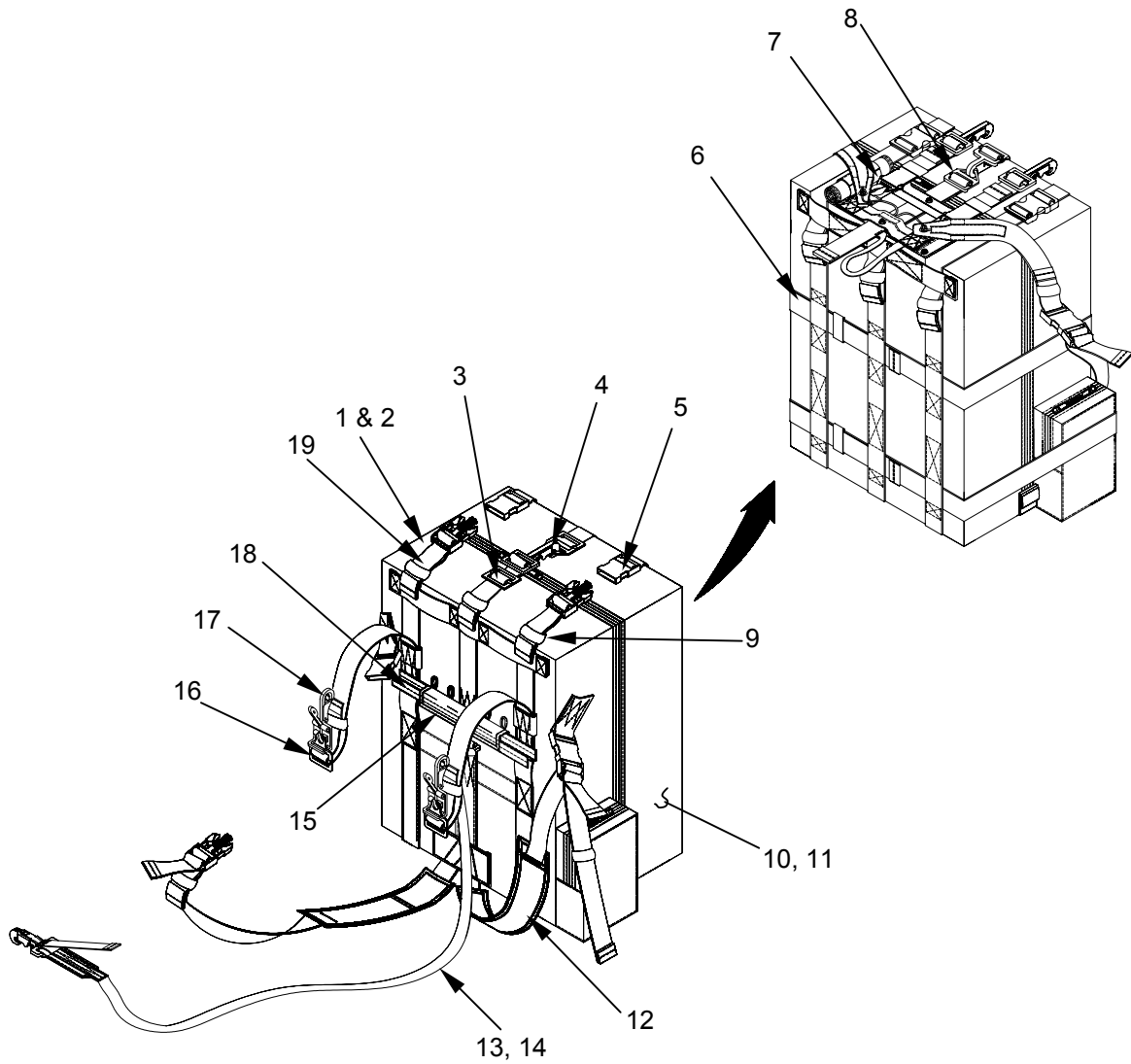

Fig 14. PARACHUTE DROP BAG

(1)	(2)	(3)	(4)	(5)	(6)	(7)
ITEM NO	SMR CODE	NATIONAL STOCK NUMBER	CAGEC	PART NUMBER	DESCRIPTION AND USABLE ON CODE (UOC)	QTY
					GROUP 14. PARACHUTE DROP BAG	
					FIG. 14. PARACHUTE DROP BAG	
1	PAOOZ	1670-01-508-9051	OD1Z5	PDB-SPR/DR-W/HW-1	Drop Bag, Parachute with 7-FT Lowering Line.....	1
2	PAOOZ	1670-01-508-9053	OD1Z5	PDB-SPR/DR-W/HW-2	Drop Bag, Parachute with 15-FT Lowering Line	1
3	PAOOZ	5342-01-073-5304	96906	MS70101-2	. Adapter, Center Vertical Strap.....	1
4	PAOOZ	5340-00-881-3038	96906	MS22043-1	. Buckle, Center Vertical Strap.....	3
5	PAOOZ	1670-01-508-0398	OD1Z5	HP0004-0200	. Buckle, Quick Release.....	2
6	PAOOZ	1670-01-508-0400	OD1Z5	PDB-SPR-HCS	. Compression Strap, Horizontal.....	2
7	PAOOZ	1670-00-862-5749	96906	MS22020-1	. Link, Triangular.....	3
8	PAOOZ	1670-01-508-3185	96906	MS70113-1	. V-Ring, Center Vertical Strap	1
9	PAOOZ	8305-00-270-1894	81349	MIL-W-5664	. Keepers, Elastic.....	AR
10	PAOOZ	8305-01-506-0532	81349	MIL-C-43734	. Cloth, duck, textured nylon, Class III. CG 483	AR
11	XDOOZ			MIL-C-43734	. Nylon, Dyed, Dark Gray.....	AR
12	PAOOZ	1670-01-508-0401	OD1Z5	PDB-SPR-BLS	. Leg Straps, Breakaway.....	2
13	PAOOZ	1670-01-508-0399	OD1Z5	PBD-SPR-15LL	. Line, Lowering, 15-Foot (Static Line).....	1
14	PAOOZ	1670-01-508-1565	OD1Z5	PBD-SPR-7LL	. Line, Lowering, 7-Foot (Military Free Fall).....	1
15	XDOOZ	8315-00-151-6480	81349	MIL-F-21840	. Fastener, Tape, Hook, 1-inch	AR
16	PAOOZ	1670-01-508-0402	96906	MS70116	. Link, Adjustable, Quick Release	2
17	PAOOZ	5340-01-036-0473	96906	PS70099-1	. Snap Hook, Quick Release.....	2
18	XDOOZ	8315-00-151-6484	81349	MIL-F-21840	. Fastener, Tape, Pile	AR
19	PAOOZ	1670-01-508-0403	OD1Z5	PDB-SPR-PHAS	. Straps, Attaching	2
					END OF FIGURE	

**UNIT MAINTENANCE
ANCILLARY EQUIPMENT FOR PERSONNEL TROOP PARACHUTE SYSTEM
NATIONAL STOCK NUMBER INDEX**

STOCK NUMBER		FIG.	ITEM	STOCK NUMBER		FIG.	ITEM
1670	00-064-5735	2	1	1670	01-077-0744	1	5
8315	00-151-6480	14	15	1670	01-079-9653	4	6
	00-151-6484	14	18			6	8
5365	00-202-0228	10	5			7	2
1670	00-217-2421	3	3			8	6
8465	00-261-4995	7	1			13	5
1670	00-263-4387	3	4			14	17
8305	00-270-1894	14	9	5340	01-097-8651	5	30
5325	00-276-4283	7	7	8465	01-109-0702	8	1
		8	8	1670	01-227-7792	5	1
5325	00-281-4356	7	6	1670	01-259-5932	6	1
		8	7	5365	01-278-0418	6	9
5340	00-360-0235	2	6			10	19
1670	00-360-0471	4	5	1670	01-283-6412	5	17
		7	3	1670	01-352-9264	10	1
		8	5	5340	01-353-0637	5	23
		13	6	5325	01-356-2566	7	5
		13	12	5340	01-364-6335	5	26
1670	00-368-4225	1	1	1670	01-413-7836	12	1
5340	00-491-1065	1	9	1670	01-414-2757	13	1
4010	00-618-4717	11	9	1670	01-415-0035	11	1
8465	00-753-6547	9	2	8305	01-506-0532	14	10
8465	00-753-6548	9	15	1670	01-508-0398	14	5
8465	00-753-6549	9	1	1670	01-508-0401	14	12
5325	00-776-1219	8	12	1670	01-508-0402	14	16
5325	00-785-8146	8	11	1670	01-508-0403	14	19
1670	00-862-5749	5	28	1670	01-508-1565	14	14
1670	00-862-5749	14	7	1670	01-508-3185	14	8
5340	00-881-3038	5	27	1670	01-508-9051	14	1
		14	4	1670	01-508-9053	14	2
1670	00-884-3668	13	10				
5340	00-887-2150	3	5				
9509	00-892-4616	1	8				
5340	01-023-9442	9	20				
5325	01-028-0945	5	20				
1670	01-035-7727	4	1				
5340	01-036-0473	4	2				
		6	3				
		7	20				
		8	4				
5340	01-050-7680	4	4				
		5	15				
		6	5				
		9	4				
		9	25				
		13	3				
		13	7				
1670	01-058-0399	14	13				
1670	01-058-0400	14	6				
1670	01-065-8196	3	2				
1670	01-067-6838	3	1				
5342	01-073-5304	14	3				

**UNIT MAINTENANCE
ANCILLARY EQUIPMENT FOR PERSONNEL TROOP PARACHUTE SYSTEM
PART NUMBER INDEX**

PART NUMBER	FIG.	ITEM	PART NUMBER	FIG.	ITEM
11-1-2501	9	20	11-1-3895-1	10	7
	13	14	11-1-3896-1	10	11
11-1-2530-1	3	1	11-1-3898-1	10	9
11-1-2714	4	1	11-1-3898-2	10	10
11-1-2716	4	3	11-1-3901-1	11	5
11-1-2721	3	2	11-1-485	6	9
11-1-3008	5	1		10	19
11-1-3009	5	2	11-1-6464-1	11	4
11-1-3009-1	5	5	11-1-6832	12	1
11-1-3009-10	5	12	11-1-6833	12	2
11-1-3009-11	5	13	11-1-6834	12	29
11-1-3009-12	5	14	11-1-6835	12	30
11-1-3009-2	5	3	11-1-6836-1	12	3
11-1-3009-3	5	4	11-1-6837	12	6
11-1-3009-4	5	6	11-1-6838	12	19
11-1-3009-5	5	7	11-1-6839	13	13
11-1-3009-6	5	8	11-1-6840	12	28
11-1-3009-7	5	9	11-1-6841	12	23
11-1-3009-9	5	11	11-1-6842	12	24
11-1-3010	5	17		12	26
11-1-3010-2	5	18	11-1-6844	12	22
11-1-3010-3	5	19	11-1-6845-1	12	5
11-1-3010-7	5	22	11-1-6847-1	12	4
11-1-3011	5	23	11-1-6848-1	12	20
11-1-3011-2	5	24	11-1-6848-2	12	7
11-1-3011-5	5	25	11-1-6849FD1	12	21
11-1-3012	5	26	11-1-6850	12	8
11-1-3012-1	5	10	11-1-6854-1	12	12
11-1-3012-4	5	29	11-1-6854-FD1	12	13
11-1-308	2	1	11-1-6854-FD2	12	14
11-1-308-1	2	3	11-1-6854-FD3	12	15
11-1-308-2	2	2	11-1-6855FD1	12	9
11-1-308-3	2	4	11-1-6855FD2	12	10
11-1-308-4	2	5	11-1-6855FD3	12	11
11-1-3398	6	1	11-1-6856	12	18
11-1-3398-20	6	2	11-1-6857FD2	12	16
11-1-3398-21	6	6	11-1-6857FD4	12	17
11-1-3401	6	4	11-1-6860-1	11	1
11-1-3403	6	7	11-1-6862-1	11	6
11-1-3890	10	1	11-1-6863-1	11	2
11-1-3890-10	10	12	11-1-6865-1	11	7
11-1-3890-11	10	13	11-1-6866	13	1
11-1-3890-12	10	14	11-1-6867	13	2
11-1-3890-13	10	15	11-1-6868	13	4
11-1-3890-14	10	16	11-1-6870	13	9
11-1-3890-15	10	17	11-1-6871	13	11
11-1-3890-16	10	18	11-1-6880	13	8
11-1-3890-21	10	20	2-2-114-10	8	14
11-1-3890-6	10	8	2-2-114-11	8	20
11-1-3891-1	10	2	2-2-114-13	8	21
11-1-3891-2	10	3	2-2-114-15	8	2
11-1-3893-1	10	4	2-2-114-23	8	16
11-1-3894-1	10	6	2-2-114-28	8	3

TM 10-1670-299-20&P

0051 00

PART NUMBER	FIG.	ITEM	PART NUMBER	FIG.	ITEM
2-2-114-6	8	17	5-4-697-3-40	9	39
2-2-114-7	8	18	5-4-697-3-41	9	40
2-2-114-8	8	13	5-4-697-3-42	9	41
2-2-114-9	8	10	5-4-697-3-43	9	42
2-2-116-1	7	4	5-4-697-3-44	9	43
2-2-116-10	7	14	5-4-697-3-5	9	19
2-2-116-11	7	15	5-4-7605F	12	27
2-2-116-12	7	16	5-4-7605M	12	25
2-2-116-14	7	17	ASTM-A580	1	8
2-2-116-18	7	19	HP0004-0200	14	5
2-2-116-2	7	8	M43770/10-CCBC1	11	3
2-2-116-20	7	18	M83420/3-002	11	9
2-2-116-4	7	9	MIL-C-10922	7	1
2-2-116-5	7	10		8	1
2-2-116-6	7	11	MIL-C-43734	14	10
2-2-116-8	7	13		14	11
2-2-116-9	7	12	MIL-F-21840	14	15
2-2-269	8	22		14	18
2-2-627	8	9	MIL-P-43304	9	1
2-2-628	8	19		9	15
2-2-632	8	15	MIL-R-3390	11	8
53D6887	1	1	MIL-R-45906	9	17
53D6887-1	1	6	MIL-W-5664	14	9
53D6887-2	1	4	MS22002-1	3	3
53D6887-3	1	2	MS22002-7	3	4
53D6887-4	1	3	MS22014-3	2	6
53D6887-5	1	7	MS22017	3	5
5-4-1602-12-4	5	20	MS22020-1	5	28
5-4-693	9	2		14	7
5-4-693-2-1	9	3	MS22040-1	13	10
5-4-693-2-4	9	5	MS22043-1	5	27
5-4-693-2-5	9	6		14	4
5-4-693-2-13	9	9	MS22045-1	4	5
5-4-693-2-14	9	10		7	3
5-4-693-2-15	9	11		8	5
5-4-693-2-16	9	13		13	6
5-4-693-2-17	9	14		13	12
5-4-693-2-6	9	7	MS220454	9	27
5-4-693-2-7	9	8	MS27977-10B	8	12
5-4-693-2-9	9	12	MS27977-1B	7	6
5-4-697-3-1	9	16		8	7
5-4-697-3-13	9	21	MS27977-3B	7	7
5-4-697-3-14	9	22		8	8
5-4-697-3-15	9	23	MS27977-64B	7	5
5-4-697-3-22	9	24	MS27977-8B	8	11
5-4-697-3-24	9	26	MS51925-2	10	5
5-4-697-3-26	9	28	MS70098	4	6
5-4-697-3-27	9	29		6	8
5-4-697-3-28	9	30		7	2
5-4-697-3-3	9	18		8	6
5-4-697-3-30	9	31	MS70098-1	13	5
5-4-697-3-31	9	32		6	3
5-4-697-3-34	9	33		7	20
5-4-697-3-35	9	34		8	4
5-4-697-3-36	9	35	MS70101-1	4	4
5-4-697-3-37	9	36		5	15
5-4-697-3-38	9	37		6	5
5-4-697-3-39	9	38		9	4

PART NUMBER	FIG.	ITEM
	9	25
	13	3
	13	7
MS70101-2	14	3
MS70108-1	1	5
MS70113-1	14	8
MS70116	14	16
MS70120	1	9
PDB-SPR/DR-W/HW-1	14	1
PDB-SPR-15LL	14	13
PDB-SPR-7LL	14	14
PDB-SPR-BLS	14	12
PDB-SPR-DR-W/HW-2	14	2
PDB-SPR-HCS	14	6
PDB-SPR-PHAS	14	19
PS70099-1	4	2
	14	17
SR2	5	30
	5	16
	5	21
U/O #4	13	15

**UNIT MAINTENANCE
ANCILLARY EQUIPMENT FOR PERSONNEL PARACHUTE SYSTEM
EXPENDABLE AND DURABLE ITEMS LIST**

EXPENDABLE AND DURABLE ITEMS LIST

This work package lists expendable and durable items that you will need to maintain the ancillary equipment. These items are authorized to you by CTA 50-790, Expendable/Durable Items (except medical, Class V repair parts, and heraldic items), or CTA 8-100, Army Medical Department Expendable/Durable Items.

Explanation of Columns in the Expendable/Durable Items List

Column (1), Item Number. This number is assigned to the entry in the listing and is referenced in the narrative instructions to identify the item.

Column (2), Level. This column identifies the lowest level of maintenance that requires the item.

Column (3), National Stock Number. This is the national stock number assigned to the item which you can use to requisition it.

Column (4), Item Name, Description, Commercial and Government Entity Code (CAGEC), and Part Number. This provides the other information you need to identify the item.

Column (5), Unit of Measure (U/M). This code shows the physical measurement or Count of an item, such as gallon, dozen, gross, etc.

EXPENDABLE AND DURABLE ITEMS LIST

Table 1. Expendable and Durable Items List.

(1) ITEM NUMBER	(2) LEVEL	(3) NATIONAL STOCK NUMBER	(4) ITEM NAME, DESCRIPTION, PART NUMBER, (CAGEC)	(5) U/M
1	O	9160-00-253-1171	Beeswax, Technical, 1-Lb, C-B-191, (81348)	LB
2	O	7920-00-282-2470	Brush, Scrub, Household, H-B-1490, (81348)	EA
3	O	7520-00-248-9285	Brush, Stenciling, H-B-00621, (81348)	EA
4	O	5350-00-221-0872	Cloth, Abrasive, Ferric Oxide and Quartz, P-C-458, (81348)	EA
5	O	8305-00-926-6870	Cloth, Cotton Duck, Type III, MIL-C-7219	YD
6	O	8305-00-170-9284	Cloth, duck, cotton, CG 483, 14.35 oz (81348) CCC-C-419	YD
7	O	8305-00-107-5834	Cloth, duck, cotton, color 07, MRWRT, 36-inch W, type I, No 6, (81348), CCC-C-419	YD
8	O		Cloth, duck, nylon, CG 483, C14, 8 oz, MIL-C-4373A	YD
9	O	8305-00-107-0079	Cloth, duck, nylon, CG483, 12.5 oz, MIL-C-43375	YD
10	O		Cloth, duck, nylon, Type II	YD
11	O	4020-00-262-2147	Cord, fibrous, nylon, type III, red Nr 70180, (81349) MIL-C-5040	YD
12	O	4020-00-246-0688	Cord, nylon, CG 483 core, type III, (81349) MIL-C-5040	YD
13	O	4020-00-262-2019	Cord, nylon, OD nylon core, type II	YD
14	O	4020-00-240-2146	Cord, nylon, NAT nylon core, type III	YD
15	O	7930-00-281-4731	Dishwashing compound, hand, flake, (81348) P-D-410	LB
16	O	Commercial	Dyed dark gray nylon, 9.0 oz	
17	O	8305-00-227-1247	Felt, 1/4-inch thick, gray, class 12R2, 92-inch long, (81348) 72-inch wide, C-F-206	SF
18	O	8305-00-290-5584	Felt, 1/4-inch, polyester, needle punched, MIL-F-44405	SF
19	O	8305-00-633-9844	Felt, 1-inch thick, 72-inch wide Type I, (81348), C-F-206	SF

Table 1. Expendable and Durable Items List.

(1) ITEM NUMBER	(2) LEVEL	(3) NATIONAL STOCK NUMBER	(4) ITEM NAME, DESCRIPTION, PART NUMBER, (CAGEC)	(5) U/M
20	O	5325-00-231-6589	Grommet, spur, Type III, (81349), MIL-G-16491	EA
21	O	7510-00-286-5362	Ink, marking, parachute, strata-blue, (81349), MIL-I-6903	PT
22	O	8330-00-299-8552	Leather, cattlehide, natural, (81348) KKL201	SF
23	O	9150-01-260-2534	Lubricant, Solid film (81349), MIL-L-2398	BX
24	O	9150-00-999-7548	Lubricant, stick form	BX
25	O	7520-00-230-2734	Mark, felt tip, black (81348) GG-M-00114	EA
26	O	7520-00-491-2917	Pen, ballpoint (81348) GG-B-60	EA
27	O	7920-00-205-3570	Rag, wiping, (81348) DDD-R-30	BL
28	O	4030-00-431-5538	Sleeve, swaging, wire cable, 5/32-inch W, (96906), MS51844-25	EA
29	O	9310-00-160-7858	Stencilboard, oiled, Type II, (81348) UU-S-265	SH
30	O	8315-00-616-0850	Tape, Binding, Nylon, Type III, 3/4-inches wide, MIL-T-5038	YD
31	O	8305-00-281-3012	Tape, Binding, Nylon, Type 12 (81349) MIL-W-4088	YD
32	O	8315-00-151-6481	Tape, fastener, Hook, 1-1/2-inch wide, CG 483	YD
33	O	8315-00-450-9837	Tape, fastener, hook, CG 483, 2-inch wide, (81349), MIL-F-21840	RL
34	O	8315-00-151-6480	Tape, fastener, hook, CG483, 1-inch wide, (81349) MIL-F-21840	RL
35	O	8315-00-151-6483	Tape, fastener, pile, CG 483, 1-1/2-inch wide, (81349), MIL-F-21840	RL
36	O	8315-00-151-6484	Tape, fastener, pile, CG 483, 1-inch wide, (58536), A-A-55126	RL
37	O	8315-00-151-6482	Tape, fastener, pile, CG 483, 2-inch wide, (58536), A-A-55126	RL
38	O	4020-00-753-6555	Tape, Lacing, and Tying	YD
39	O	8315-00-255-7673	Tape, nylon, Type III, CG 483, 1/2-inch W, (81349), MIL-T-5038	YD

Table 1. Expendable and Durable Items List.

(1) ITEM NUMBER	(2) LEVEL	(3) NATIONAL STOCK NUMBER	(4) ITEM NAME, DESCRIPTION, PART NUMBER, (CAGEC)	(5) U/M
40	O	7510-00-266-5016	Tape, pressure sensitive, 2-inch W, Type IV, (81348) PPP-T-60	RL
41	O	8315-00-253-6289	Tape, textile, cotton, 3/4-inch W, Type I, MIL-T-43566	YD
42	O	8315-00-253-6292	Tape, textile, cotton, 1-1/2-inch wide, CG 483, Type I, (81349), MIL-T-43566	YD
43	O	8315-00-253-6290	Tape, textile, cotton, 1-inch wide, CG 483, Type I, (81349), MIL-T-43566	YD
44	O	8315-00-260-2561	Tape, Textile, Cotton, type II, 1-inch wide, (81349), MIL-W-5665	YD
45	O	8305-00-261-8579	Tape, textile, webbing, Type IV, CG 483, MIL-T-5038	YD
46	O	8310-00-917-3945	Thread, cotton, ticket 8/7, natural, (58536), A-A-52094	RL
47	O	8310-00-267-3027	Thread, nylon, size 3, CG 483, (81348), V-T-295	RL
48	O	8310-00-262-2777	Thread, nylon, size 5, CG 483, (81348), V-T-295	RL
49	O	8310-00-262-2780	Thread, nylon, size 6, CG 483, (81348), V-T-295	RL
50	O	8310-00-262-2772	Thread, nylon, size E, CG 483, (81348), V-T-295	RL
51	O	8310-00-227-1244	Thread, nylon, size FF, CG 483, (81348), V-T-295	RL
52	O	8310-00-285-2044	Wax, paraffin, Type I, technical, grade A, (81348) VV-W-95	LB
53	O		Webbing, Absorb-edge, 24k breaking strength, gray, 4-inch wide	YD
54	O	8305-00-263-2462	Webbing, cotton, 1-inch wide, type III, (81349), MIL-W-530	YD
55	O	8305-00-260-2564	Webbing, cotton, Type VII, CG 483	YD
56	O	8305-00-260-2564	Webbing, cotton/nylon, Type VIII, CG 483, 1.75-inch wide, (81349), MIL-W-5665	YD
57	O	8305-00-263-3592	Webbing, nylon, 1-inch wide, Type II, (81349), MIL-W-4088	YD
58	O	8315-00-263-3604	Webbing, Nylon, 1-inch wide, Type III, CG 483	YD
59	O	8305-00-261-8856	Webbing, nylon, CG 483, Type I, 9/16-inch W (81349), MIL-W-4088	YD

Table 1. Expendable and Durable Items List.

(1) ITEM NUMBER	(2) LEVEL	(3) NATIONAL STOCK NUMBER	(4) ITEM NAME, DESCRIPTION, PART NUMBER, (CAGEC)	(5) U/M
60	O	8305-00-261-8579	Webbing, nylon, CG 483, Type IV, (81349), MIL-T-5038	YD
61	O	8305-00-261-8585	Webbing, nylon, CG 483, Type VIII, (81349), MIL-W-4088	YD
62	O	8305-00-261-8584	Webbing, nylon, CG 483, Type X, (81349), MIL-W-4088	YD
63	O	8305-01-206-9219	Webbing, nylon, CG 483, Type XXVI, (81349), MIL-W-4088	YD
64	O	8305-00-782-6734	Webbing, nylon, Type VII, 1 9/16-inch wide, (81349), MIL-W-4088	YD
65	O	8305-00-782-6734	Webbing, Nylon, Type VII, CG 483, MIL-W-4088	YD
66	O	8305-00-260-6890	Webbing, Nylon, Type X	YD
67	O	8305-00-260-4586	Webbing, Nylon, Type XIII, MIL-W-27265	YD
68	O		Webbing Reinforcement, (81349)	YD
69	O	8315-00-263-3604	MIL-W-4088 Webbing, text, textured or multifilament nylon, CG 483, Type III, (81349), MIL-W-4088	YD
70	O	8305-00-559-6871	Webbing, textile, woven, nylon, Type VIII, Class I, yellow, (81349), MIL-W-4088	YD
71	O	8305-00-268-2455	Webbing, tubular, nylon, CG 483, 1-inch wide, (81349), MIL-W-5625	YD
72	O	8305-00-753-3258	Webbing, tubular, nylon, CG 483, 5/8-inch wide, (81349), MIL-W-5625	YD
73	O	8305-00-261-8582	Webbing, tubular, nylon, CG 483, 9/16-inch wide, (81349), MIL-W-5625	YD
74	O	8305-00-082-5751	Webbing, tubular, nylon, natural, 3/4-inch wide, (81349), MIL-W-5625	YD
75	O	8305-00-753-3258	Webbing, tubular, nylon, natural, 5/8-inch wide, (81349), MIL-W-5625	YD
76	O	4010-00-618-4717	Wire, rope, type IIB, coated, 5/32-inch W, (81349), MIL-W-83420	EA
77	O	9509-00-892-4616	Wire, steel, composition, .080-inch dia, 430, QQ-W-423, form 1, condition A, (81346)	RL

Table 1. Expendable and Durable Items List.

(1) ITEM NUMBER	(2) LEVEL	(3) NATIONAL STOCK NUMBER	(4) ITEM NAME, DESCRIPTION, PART NUMBER, (CAGEC)	(5) U/M
78	O	8305-01-506-0532	Cloth, Duck, Textured Nylon, Class III, CG 483	RL
79	O	7510-00-266-6710	Tape, Masking, 2-inch wide	RL
80	O	8315-00-253-6265	Tape, Nylon, Type III, 3/4-Inch	YD
81	O	8305-00-753-6529	Webbing, Tubular, Nylon, 1-Inch, Yellow	YD

**UNIT MAINTENANCE
ANCILLARY EQUIPMENT FOR PERSONNEL PARACHUTE SYSTEM
ILLUSTRATED LIST OF MANUFACTURED ITEMS**

INTRODUCTION**Scope**

This work package includes complete instructions for making items authorized to be manufactured or fabricated at the unit maintenance level.

How to Use the Index of Manufactured Items

A part number index in alphanumeric order is provided for cross-referencing the part number of the item to be manufactured to the page which covers fabrication criteria.

Explanation of the Illustrations of Manufactured Items

All instructions needed by maintenance personnel to manufacture the item are included on the illustrations. All bulk materials needed for manufacture of an item are listed by part number or specification number in a tabular list on the illustration.

EQUIPMENT	PART NUMBER	NOMENCLATURE	FIG NO
Extension Static Line, Standard, 5-Foot	ASTM-A580	Wire Safety	1
Accessory Set, SCUBA	11-1-308-1	Strap, Support	2
	11-1-308-3	Harness, Backstrap	3
	11-1-308-4	Strap, Waistband Extension	4
Jump Pack Dragon Missile	11-1-2716	Pocket Assembly, Lowering Line	5
Harness Single Point Release	11-1-3009-3	Strap, Cross Adjustable	6
Pack, Assembly, AT4	11-1-3401	Pocket Assembly, Lowering Line	7
	11-1-3403	Forward End Cross Strap	8
Case, Parachutist's M-1950 (Cotton)	2-2-116-1	Pocket Assembly, Lowering	9
	2-2-116-2	Strip Panel	10
Case, Parachutist's M-1950 (Nylon)	2-2-629	Pocket Assembly, Lowering	11

EQUIPMENT	PART NUMBER	NOMENCLATURE	FIG NO
	2-2-629	Lower Strap Pocket Assembly	12
	2-2-632	Lower Leg Strap Assembly	13
Parachutist's Weapons And Individual Equipment Pack and Harness Assembly	5-4-697-3-24	Upper Suspension Strap	14
	5-4-697-3-42	Pocket Assembly, Lowering	15
	5-4-697-3-15	Handle	16
Jump Pack Stinger Missile	11-1-3890-15	Strap, Carrying	17
Arctic Rigging Extension	N/A	Waistband, Modified	18
Container Front Mount	11-1-6832	Horizontal Restraint Assembly	19
		Vertical Restraint Assembly	20
		Closing Flap Assembly	21
		Lowering Line Pocket, Flaps and Loop	22
		Side Container Assembly	23
		Kit, Bag Assembly	24
		Bridle Assembly	25
		Attaching Strap	26
		Release Handle Assembly	27
Container Side Mount	11-1-6866	Upper Cap Assembly	28
		Lower Cap Assembly	29
		Lower Line Bridle Assembly	30

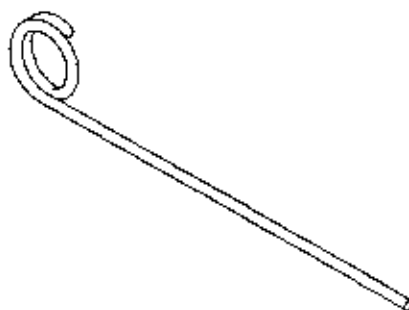
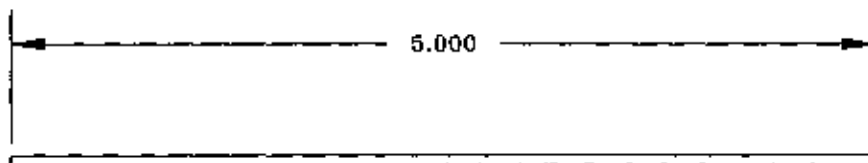

Fig. 1 (EXTENSION STATIC LINE) WIRE SAFETY

PROCEDURE	MATERIALS	NOTE
1. CUT WIRE TO LENGTH INDICATED.	WIRE, STEEL, ASTM-A580 .080-IN DIA.	DIMENSIONS SHOWN ARE IN INCHES.
2. BEND WIRE AS SHOWN		TOLERANCE IS 1/8-IN.

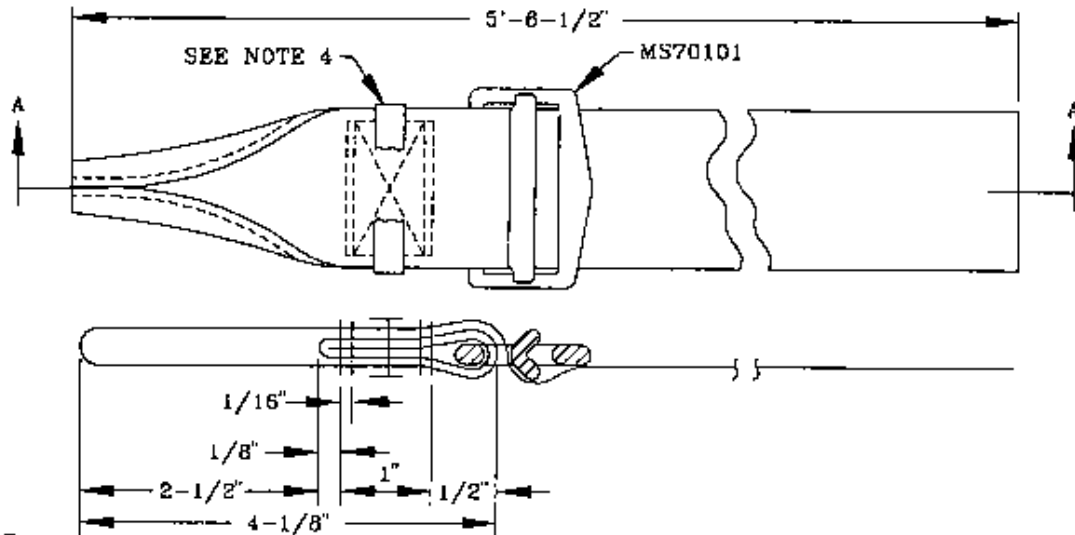

Fig. 2 (ACCESSORY SET, SCUBA) STRAP, SUPPORT

PROCEDURE	MATERIALS	NOTE
1. CUT 6-FT 4-IN LENGTH OF NYLON WEBBING.	WEBBING, NYLON, TYPE VIII, CLASS R, CG 483, MIL-W-27265	DIMENSIONS SHOWN ARE INCHES.
2. SEAR ONE END AS DESCRIBED IN WP 0013 00.	RUBBER BAND, TYPE I OR II	TOLERANCE IS 1/8-IN.
3. INSTALL QUICK FIT ADAPTER.	THREAD, NYLON, SIZE 3, TYPE I OR II, V-T-295	
4. FOLD AND SEW WEBBING AS SHOWN USING SIZE 3 THREAD 5 TO 8 STITCHES PER INCH AND A HD SEWING MACHINE.		
5. CUT OTHER END OF WEBBING TO LENGTH INDICATED AND SEAR END AS DESCRIBED IN WP 0013 00.		

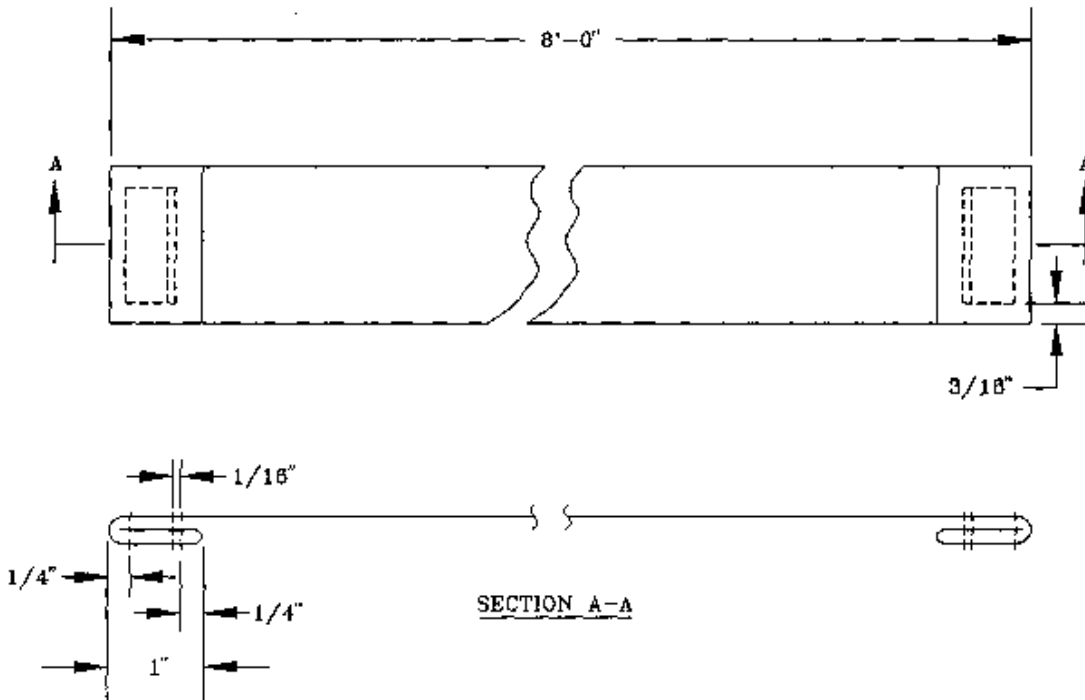

Fig. 3 (ACCESSORY SET, SCUBA) HARNESS, BACKSTRAP

PROCEDURE	MATERIALS	NOTE
1. CUT 8-FT 4-IN LENGTH OF WEBBING MATERIAL.	WEBBING, NYLON, TYPE VIII, CLASS R, CG 483, MIL-W-27265	DIMENSIONS SHOWN ARE IN INCHES.
2. SEAR ENDS AS DESCRIBED IN WP 0013 00.	THREAD, SIZE 6, OD, V-T-295	TOLERANCE IS 1/8-IN.
3. FOLD AS SHOWN AND SEW USING SIZE 6 THREAD, 5 TO 8 STITCHES PER INCH AND A HD SEWING MACHINE.		

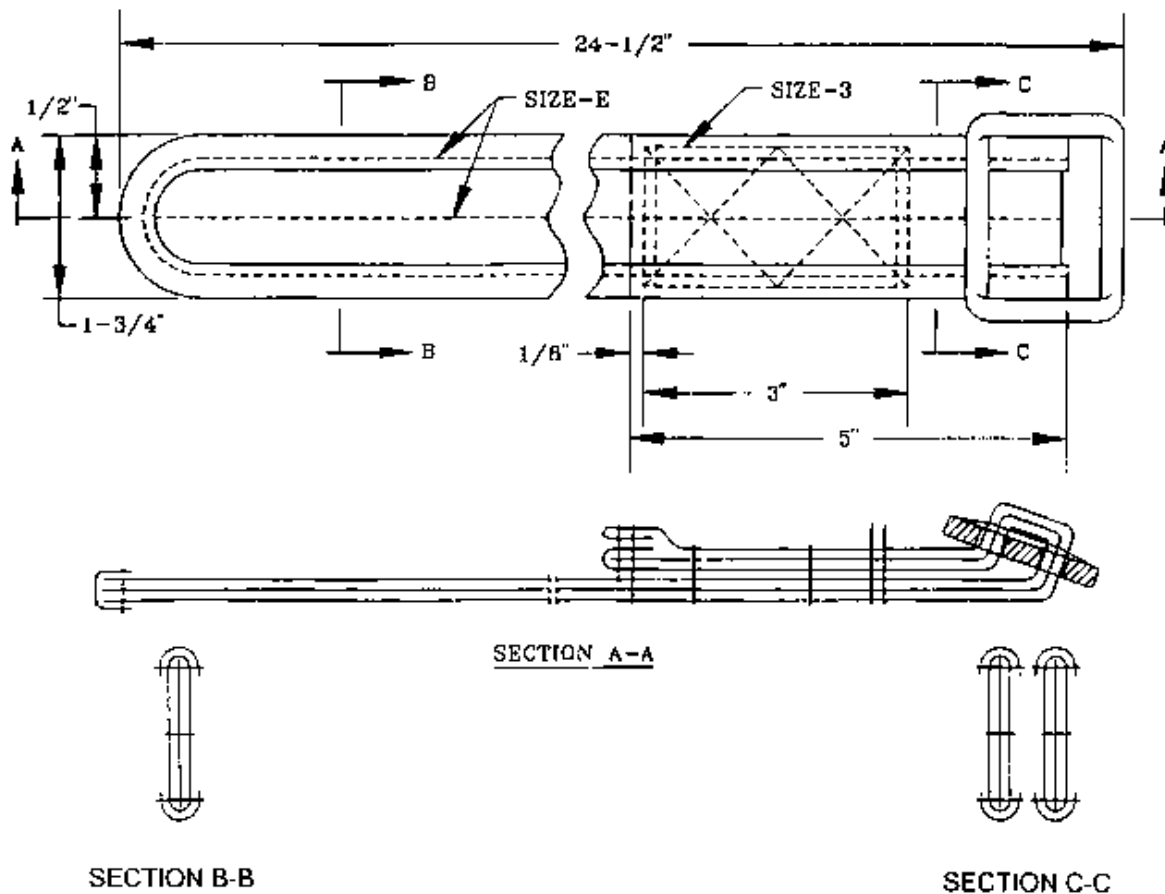

Fig. 4 (ACCESSORY SET, SCUBA) STRAP, WAISTBAND EXTENSION

PROCEDURE	MATERIALS	NOTE
1. CUT A 29-1/2-IN LENGTH OF WEBBING MATERIAL AND SEAR ENDS.	WEBBING, NYLON, OD, MIL-W-27265	DIMENSIONS SHOWN ARE IN INCHES.
2. CUT TWO 30-IN LENGTHS OF 1-3/4-IN WIDE NYLON CLOTH.	CLOTH, NYLON DUCK, TYPE III, MIL-C-7219	TOLERANCE IS 1/8-IN.
3. SANDWICH WEBBING BETWEEN NYLON CLOTH STRIPS AND SEW ALONG CENTER AS SHOWN USING SIZE E THREAD, 7 TO 11 STITCHES PER INCH AND A LD SEWING MACHINE.	THREAD, NYLON, SIZE 3, V-T-295 TAPE, BINDING, NYLON TYPE III, 3/4-IN WIDE, MIL-T-5038	
4. CUT ROUNDED END ON OTHER END OF ASSEMBLY AS SHOWN.	THREAD, NYLON, SIZE E, V-T-295	
5. TURN BINDING UNDER 1/2-IN AND SEW TO ASSEMBLY USING METHOD 3 ABOVE.		
6. INSTALL ADAPTER ON STRAP.		
7. FOLD STRAP AS SHOWN AND APPLY BOX X STITCH USING SIZE 3 THREAD, 5 TO 8 STITCHES PER INCH AND A HD SEWING MACHINE.		

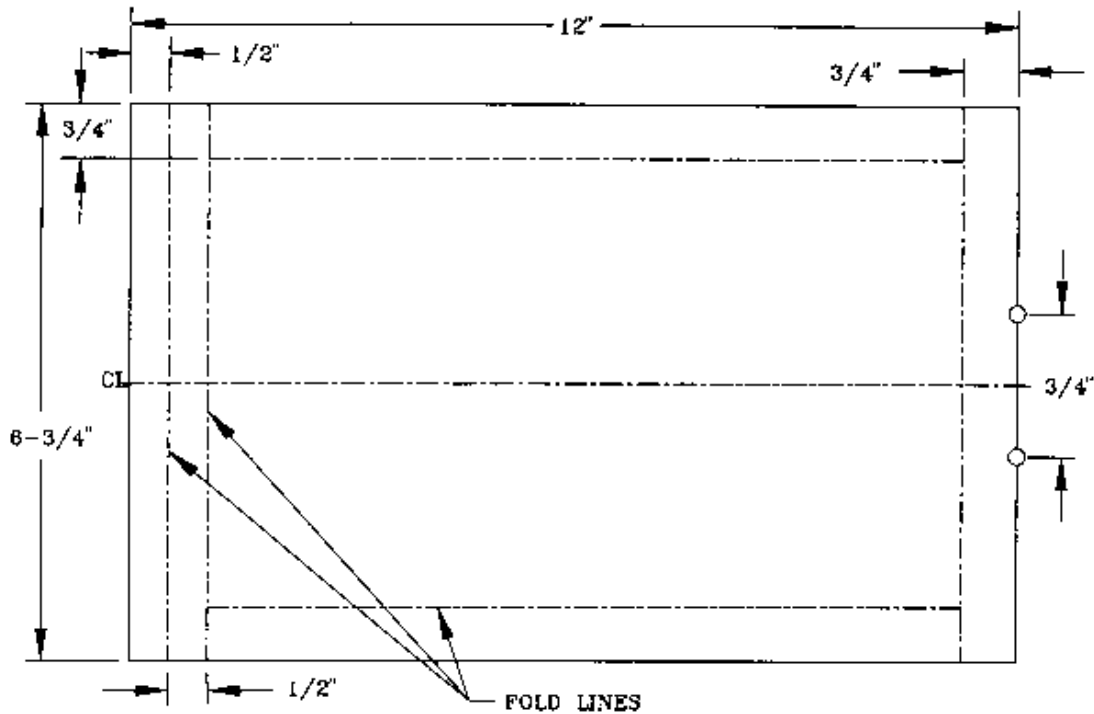

Fig. 5 (JUMP PACK, DRAGON MISSILE) POCKET ASSEMBLY, LOWERING LINE

PROCEDURE	MATERIALS	NOTE
1. CUT CLOTH TO DIMENSIONS SHOWN.	CLOTH, DUCK, COTTON, TYPE X	DIMENSIONS SHOWN ARE IN INCHES.
2. FOLD CLOTH ALONG FOLD LINES INTO POCKET SHOWN.	THREAD, NYLON, SIZE E	TOLERANCE IS 1/8-IN.
3. SEW LENGTHWISE FOLDS AS SHOWN.		
4. PLACE POCKET ONTO PACK AND SEW AS SHOWN IN VIEW D. USE 7 TO 11 STITCHES PER INCH AND A LD SEWING MACHINE.		

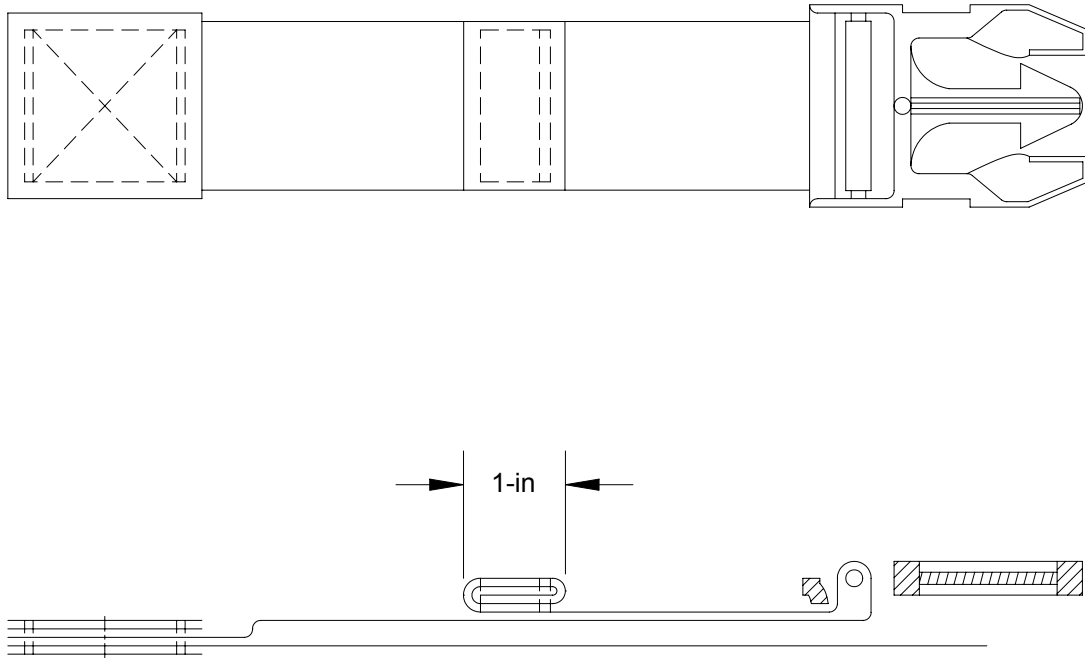

Fig. 6 (HARNESS, SINGLE POINT RELEASE) STRAP, CROSS ADJUSTABLE

PROCEDURE	MATERIALS	NOTE
1. CUT 62-IN LENGTH OF WEBBING AND SEAR ENDS.	WEBBING, NYLON, TYPE VIII.	DIMENSIONS SHOWN ARE IN INCHES.
2. THREAD ON END OF WEBBING THROUGH SIDE RELEASE BUCKLE AND FOLD END FOUR TIMES. SEW WITH SIZE 3 THREAD, 5 TO 8 STITCHES PER INCH AND HD SEWING MACHINE.	THREAD, NYLON, SIZE 3	TOLERANCE IS 1/8-IN.

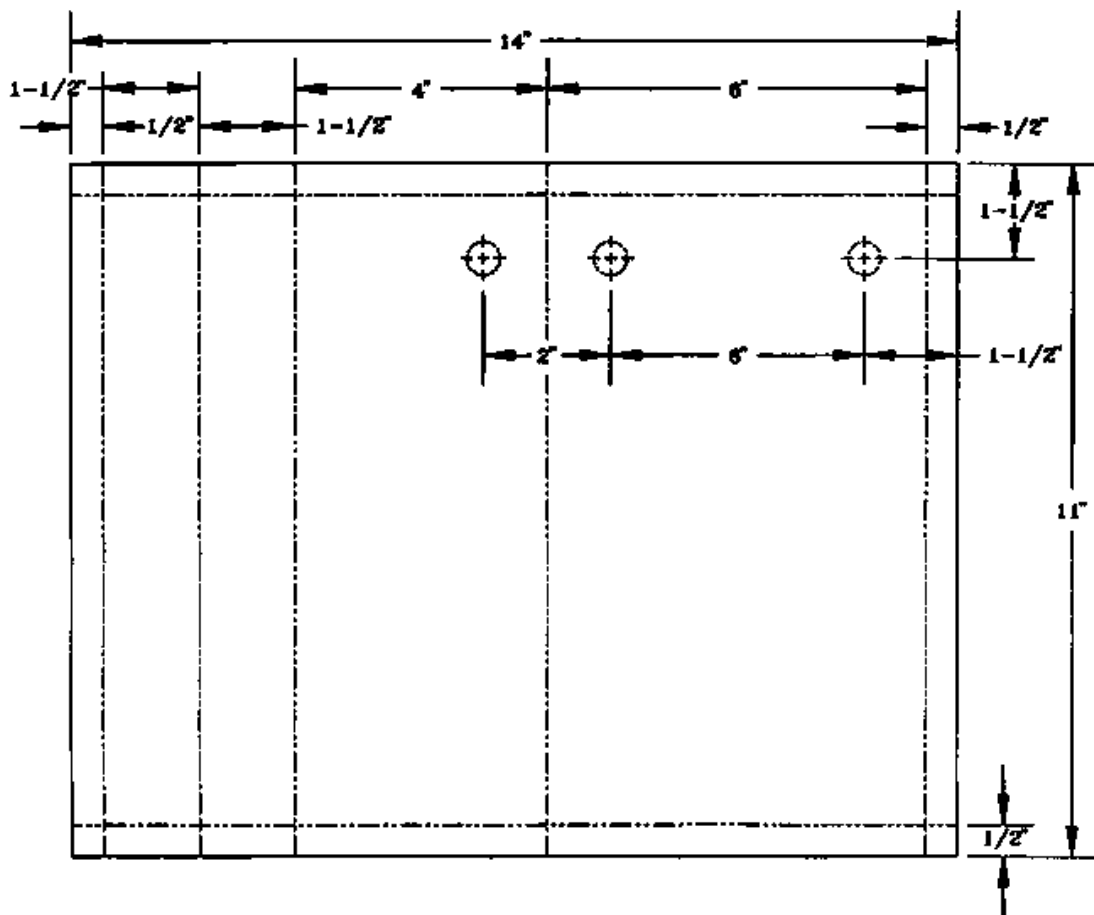

Fig. 7 (AT4 PACK) POCKET ASSEMBLY LOWERING LINE (SHEET 1 OF 2)

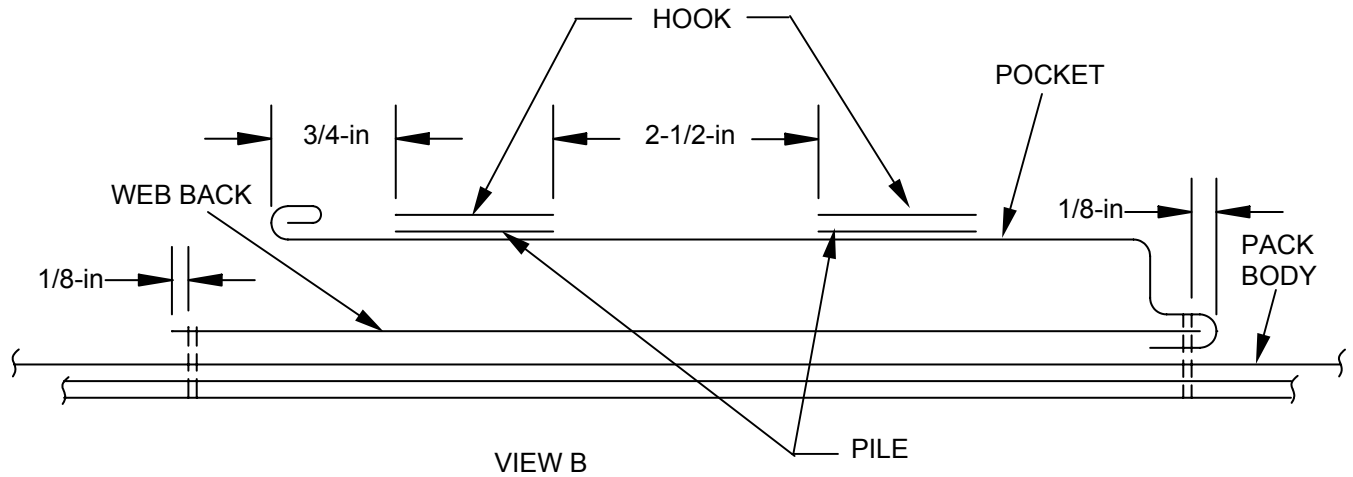

Fig. 7 (AT4 PACK) POCKET ASSEMBLY LOWERING LINE (SHEET 2 OF 2)

PROCEDURE	MATERIALS	NOTE
1. CUT CLOTH TO DIMENSIONS SHOWN IN VIEW A.	CLOTH, DUCK, NYLON, TYPE X.	DIMENSIONS SHOWN ARE IN INCHES.
2. DOUBLE FOLD TOP EDGE OF POCKET 1/2-IN. STITCH WITH SIZE FF THREAD, 6 TO 9 STITCHES PER INCH AND A MD SEWING MACHINE.	THREAD, NYLON, SIZE FF THREAD, NYLON, SIZE 3	TOLERANCE IS 1/8-IN.
3. ALIGN CORNERS (1) AND (2) AND SEW SIDES 1/2-IN FROM EDGE. SEW CORNERS (3) AND (4) IN SAME MANNER.	TAPE, FASTENER, PILE 2-IN WIDE TAPE, FASTENER, HOOK 2-IN WIDE	
4. REPLACE HOOK AND PILE TAPE AS SHOWN IN VIEW B. SEW AS IN 2. ABOVE.		
5. CUT AN 11-IN LENGTH OF NYLON WEBBING AND SEAR ENDS.		

(AT4 PACK) POCKET ASSEMBLY LOWERING LINE-CONTINUED

6. TURN UNDER RAW EDGE OF POCKET 1/2-IN AND POSITION ON WEBBING BACK 1-IN FROM EDGE LOCATING TOP AND BOTTOM HOOK AND PILE RETAINERS 1-IN AND 4-IN FROM THE TOP OF POCKET. STITCH POCKET SIDES AND BOTTOM TO REINFORCEMENT WEBBING 3/16-IN FROM EDGE. SEW AS IN 2. ABOVE,
7. PLACE POCKET ON PACK AND STITCH TO PACK 1/8-IN FROM POCKET EDGE WITH SIZE 3 THREAD, 5 TO 8 STITCHES PER INCH AND A MD SEWING MACHINE.

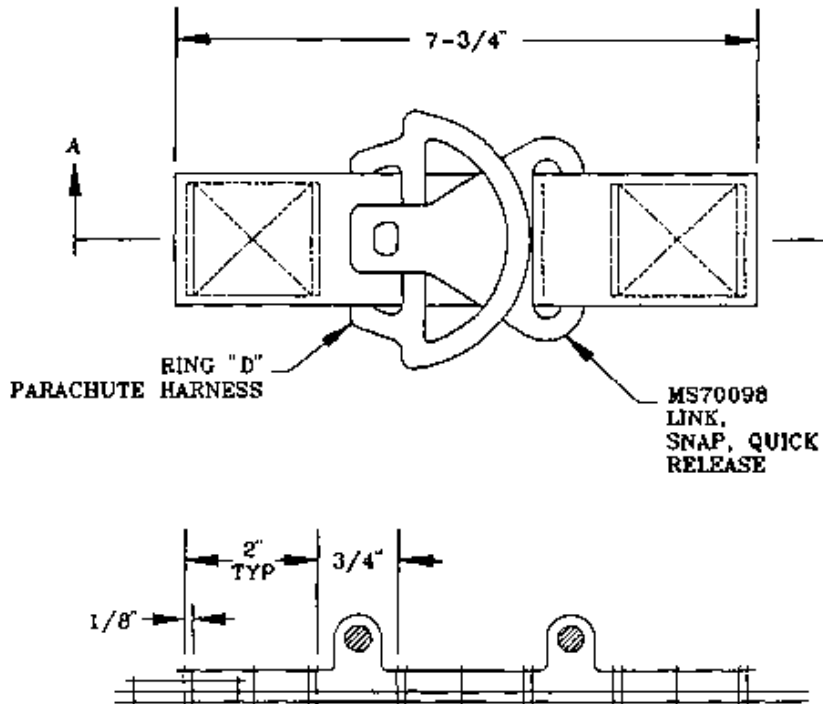

Fig. 8 (AT4 PACK) FORWARD END CROSS STRAP

PROCEDURE	MATERIALS	NOTE
1. CUT WEBBING TO LENGTH SHOWN AND SHEAR ENDS.	WEBBING, NYLON, TYPE VIII	DIMENSIONS SHOWN ARE IN INCHES.
2. MARK WEBBING 2-1/8-IN FROM EACH END.	THREAD, NYLON, SIZE 3	TOLERANCE IS 1/8-IN.
3. POSITION CHAPE ON PACK AND SEW USING SIZE 3 THREAD, 5 TO 8 STITCHES PER INCH AND A HD SEWING MACHINE.		

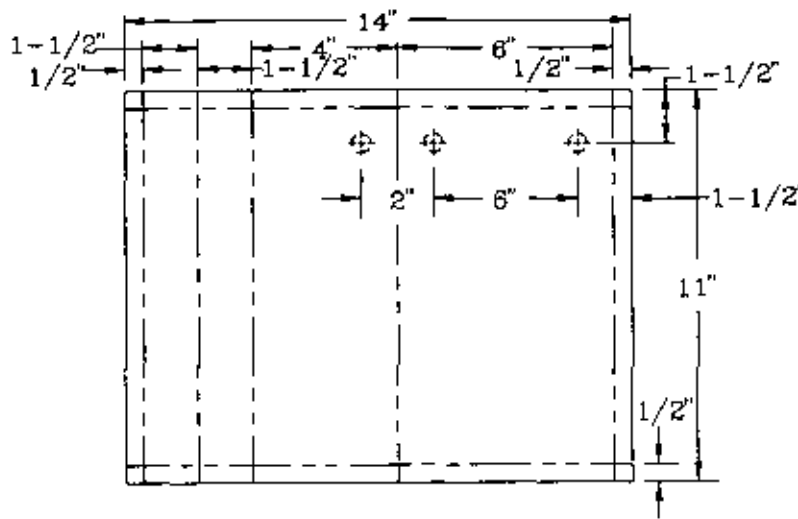

Fig. 9 (INDIVIDUAL WEAPONS CASE, M-1950 (COTTON)) POCKET ASSEMBLY, LOWERING

PROCEDURE	MATERIALS	NOTE
1. CUT A 14-IN BY 11-IN LENGTH OF CLOTH. ENSURE THAT ONE OF THE 14-IN SIDES RUN ALONG THE SELVAGED EDGE OF THE MATERIAL.	CLOTH, DUCK, COTTON, TYPE I, 36-IN WIDE	DIMENSIONS SHOWN ARE IN INCHES.
2. MARK FOLD LINES, AND POSITIONS OF SNAP FASTENERS ON MATERIAL AS SHOWN.	THREAD, NYLON, SIZE FF	TOLERANCE IS 1/8-IN.
3. TURN UNDER SELVAGED EDGE 1/2-IN AND SEW ALONG MATERIAL 1/4-IN FROM EDGE. USE SIZE FF THREAD, 6 TO 9 STITCHES PER INCH AND A MD SEWING MACHINE		
4. FOLD CLOTH ALONG FOLD LINES, PLACING SELVAGE EDGE ON INSIDE. SEW MATERIAL ALONG FOLD LINE 1/8-IN FROM FOLD. INSTALL SNAP FASTENERS AS DESCRIBED IN WP 0015 00.		

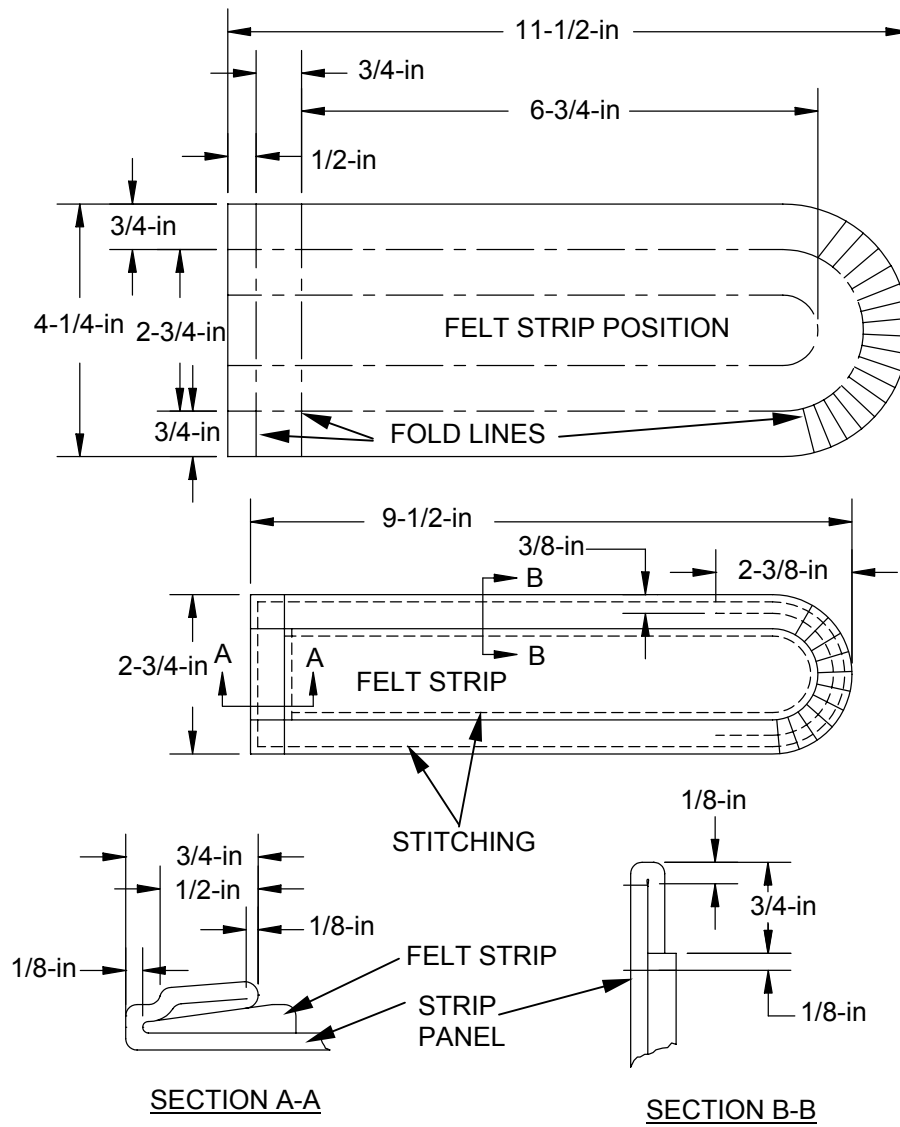

Fig. 10 (INDIVIDUAL WEAPONS CASE (COTTON)) M-1950, STRIP PANEL

PROCEDURE	MATERIALS	NOTE
1. CUT A 4-1/4-IN BY 11- 1/2-IN LENGTH OF CLOTH AND A 1-1/4-IN BY 8 -3/4-IN PIECE OF 1/4-IN FELT. ROUND ONE END OF DUCK AND FELT AS SHOWN.	CLOTH, DUCK, COTTON, TYPE I, 36-IN WIDE THREAD, NYLON, SIZE 3 FELT, 1/4-IN THICK	DIMENSIONS SHOWN ARE IN INCHES. TOLERANCE IS 1/8-IN.
2. POSITION FELT ON DUCK AND SEW AS SHOWN USING SIZE FF THREAD 6 TO 9 STITCHES PER INCH AND A HD SEWING MACHINE.	THREAD, NYLON, SIZE FF	

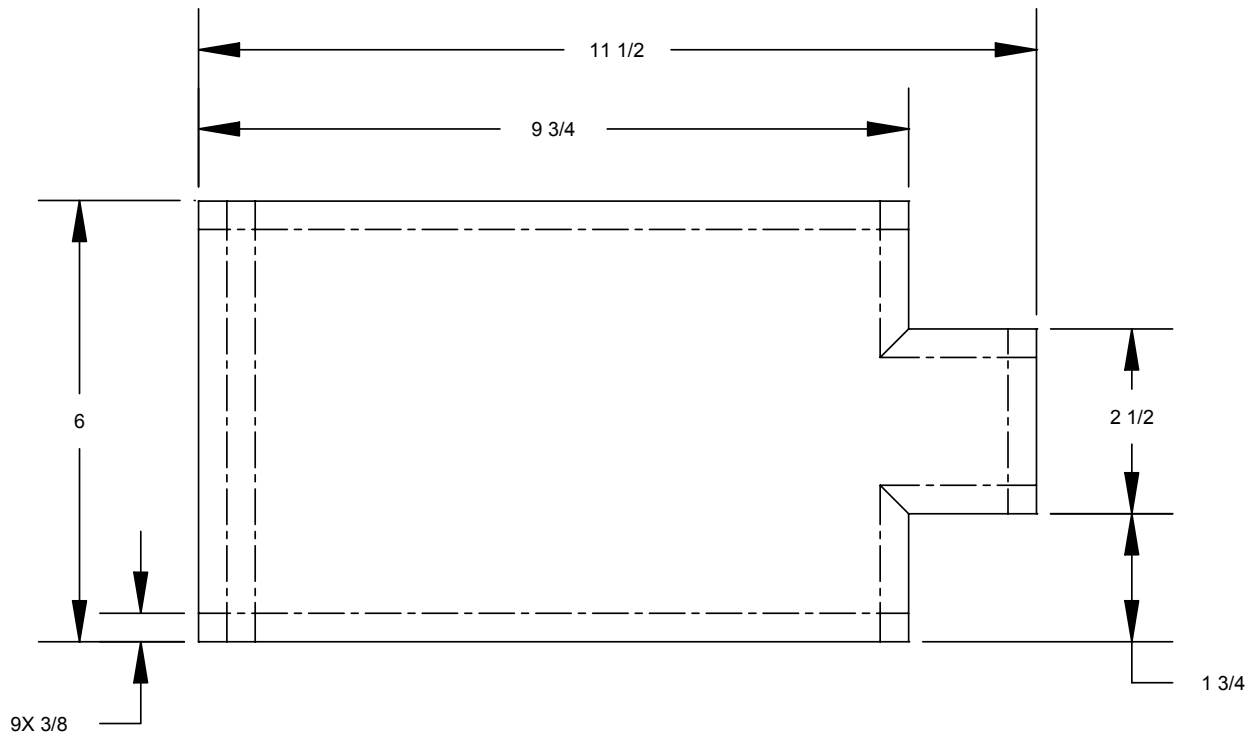

Fig. 11 (INDIVIDUAL WEAPONS CASE, M-1950 (NYLON)) POCKET ASSEMBLY, LOWERING

PROCEDURE	MATERIALS	NOTE
1. CUT AN 11-1/2-IN BY 6-IN LENGTH OF CLOTH. ENSURE THAT ONE OF THE 11-1/2-IN SIDES RUN ALONG THE SELVAGED EDGE OF THE MATERIAL.	CLOTH, DUCK, NYLON, 12.5 OUNCE, CLASS 2-DYED, WATER REPELLANT, PER MIL-C-43375, COLOR CAMOUFLAGE GREEN NO.483	DIMENSIONS SHOWN ARE IN INCHES.
2. MARK FOLD LINES ON MATERIAL AS SHOWN.	THREAD, NYLON, SIZE FF	TOLERANCE IS 1/8-IN.
3. TURN UNDER SELVAGED EDGE 3/8-IN AND SEW ALONG MATERIAL 3/8-IN FROM EDGE. USE SIZE FF THREAD, 6 TO 9 STITCHES PER INCH AND A MD SEWING MACHINE.		
4. FOLD CLOTH ALONG FOLD LINES, PLACING SELVAGE ON INSIDE. SEW MATERIAL ALONG FOLD LINE 3/8-IN FROM FOLD.		

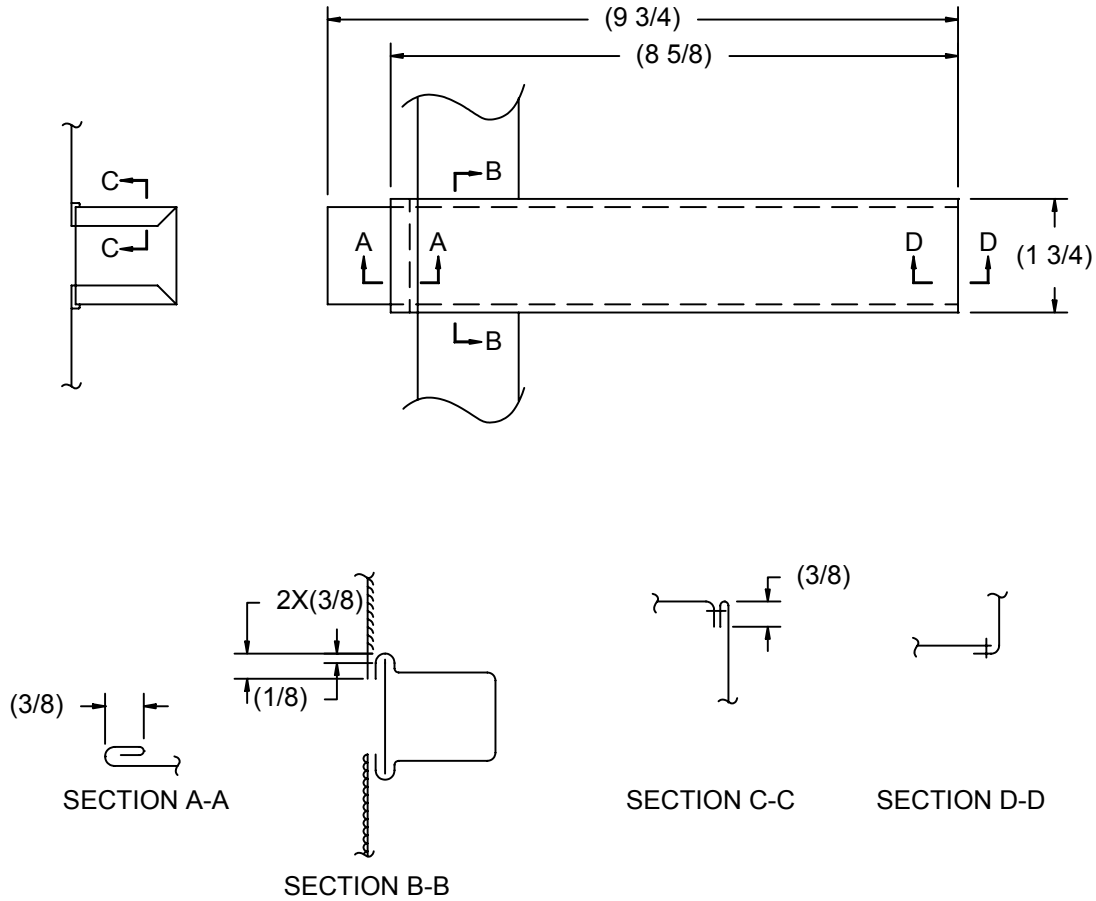

Fig. 12 (INDIVIDUAL WEAPONS CASE, M-1950 (NYLON)) LOWER STRAP POCKET ASSEMBLY

PROCEDURE	MATERIALS	NOTE
1. FABRICATE LOWER STRAP POCKET ASSEMBLY	WEBBING, TEXTILE TYPE XII	DIMENSIONS SHOWN ARE IN INCHES.
2. FUSE ALL EXPOSED ENDS OF NYLON TAPE EVEN TO PREVENT FRAYING. AVOID FORMING SHARP EDGES.	FASTENER, PILE 1-1/2-IN WIDE FASTENER, HOOK, 1-1/2-IN WIDE THREAD, NYLON, SIZE FF	ALL STITCHING SHALL BE BACKSTITCHED NOT LESS THAN 1-IN UNLESS TURNED UNDER BY A HEM OR HELD DOWN BY OTHER STITCHING. ALL STITCHING TO BE 1/8-IN FROM EDGE OR SPACED 1/8-IN APART. TOLERANCES: 1/8-IN OR MORE BUT LESS THAN 2-IN: 1/16-IN. 2-IN OR MORE BUT LESS THAN 10-IN: 1/8-IN.

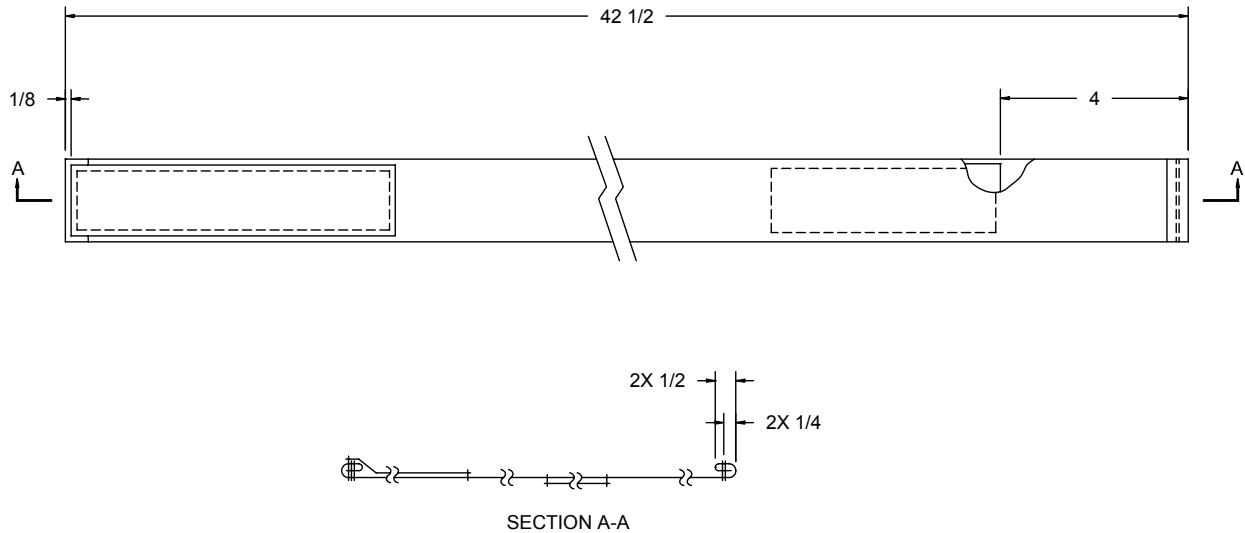

Fig. 13 (INDIVIDUAL WEAPONS CASE, M-1950 (NYLON)) LOWER LEG STRAP ASSEMBLY

PROCEDURE	MATERIALS	NOTE
1. FABRICATE LOWER LEG STRAP ASSEMBLY	WEBBING, NYLON TYPE VIII	DIMENSIONS SHOWN ARE IN INCHES.
2. FUSE ALL EXPOSED ENDS OF NYLON TAPE EVEN TO PREVENT FRAYING. AVOID FORMING SHARP EDGES.	FASTENER, PILE 1-1/2-IN WIDE FASTENER, HOOK 1-1/2-IN WIDE THREAD, NYLON, SIZE FF	TOLERANCES: 1/8-IN OR MORE BUT LESS THAN 2-IN: 1/16-IN. 2-IN OR MORE BUT LESS THAN 10-IN: 1/8-IN. 10-IN OR MORE BUT LESS THAN 30-IN: 1/4-IN. 30-IN OR MORE: 1/2-IN

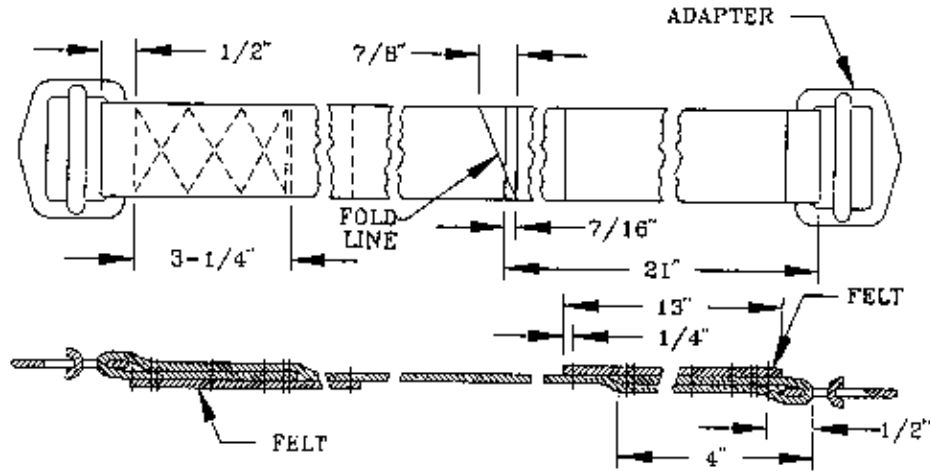

Fig. 14 (EQUIPMENT PACK AND HARNESS ASSEMBLY) UPPER SUSPENSION STRAP

PROCEDURE	MATERIALS	NOTE
1. CUT A 50-IN LENGTH OF WEBBING AND SEAR ENDS.	WEBBING, NYLON, TYPE VIII	DIMENSIONS SHOWN ARE IN INCHES.
2. INSTALL ADAPTERS AT BOTH ENDS OF WEBBING IN OPPOSITE DIRECTION AND FOLD ENDS OVER 4-IN.	FELT, 1/4" CLASS 12R2 GRAY. THREAD, NYLON, SIZE FF	TOLERANCE IS 1/8-IN.
3. SEW TRIPLE X STITCH AT EACH END OF WEBBING, USING SIZE FF THREAD, 6 TO 9 STITCHES PER INCH, AND A MD SEWING MACHINE.		
4. CUT TWO 1-3/4-IN X 13-IN LENGTHS OF 1/4-IN FELT AND POSITION AT EACH END OF STRAP OVER 4-IN FOLD, AND SEW TO STRAP 1/4-IN FROM THE EDGE, AS IN 3. ABOVE.		

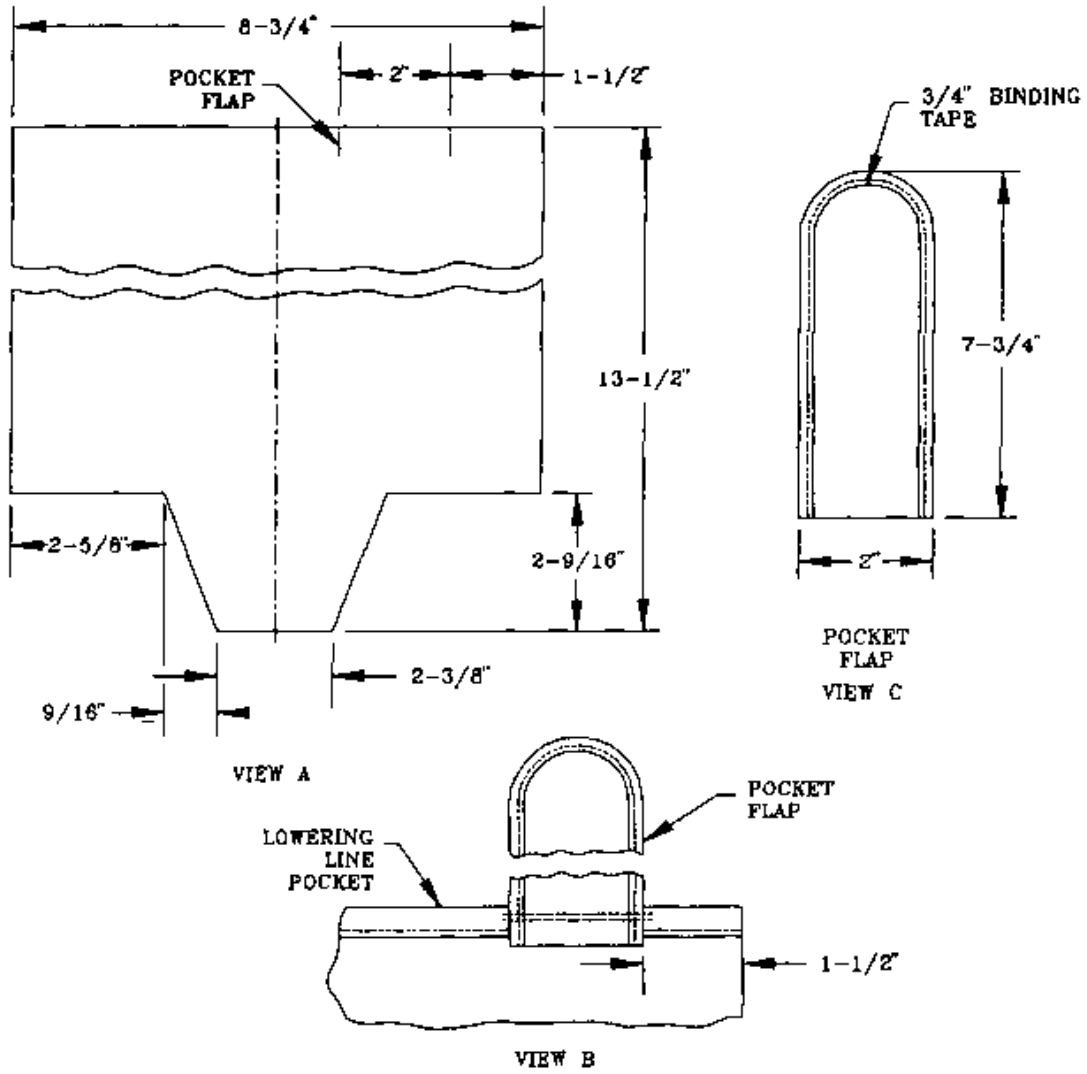

Fig. 15 (EQUIPMENT PACK AND HARNESS ASSEMBLY) POCKET ASSEMBLY, LOWERING

PROCEDURE	MATERIALS	NOTE
1. CUT A PIECE OF CLOTH TO THE DIMENSION SHOWN IN VIEW A.	CLOTH, DUCK, COTTON, TYPE I	DIMENSIONS SHOWN ARE IN INCHES.
2. ALIGN CORNER (1) WITH CORNER (2) AND SEW THE ALIGNED SIDES TOGETHER 1/2-IN FROM EDGE USING SIZE 3 THREAD, 5 TO 8 STITCHES PER INCH AND A HD SEWING MACHINE	THREAD, NYLON, SIZE 3 TAPE, TEXTILE, COTTON USE TYPE I, 1-IN WIDE	TOLERANCE IS 1/8-IN.
3. SEW CORNER (3) TO CORNER		
4. TURN POCKET RIGHT SIDE OUT, AND POSITION FLAP SO THAT RIGHT EDGE OF FLAP IS 1-1/2-IN FROM RIGHT POCKET EDGE, AND AND BOTTOM FLAP 3/4-IN BELOW SELVAGED EDGE.		
5. TURN BACK SELVAGED EDGE OF POCKET 3/4-IN AND SEW AS SHOWN IN VIEW B AS IN 2. ABOVE. THEN FOLD FLAP BACK AND SEW TWO ROWS OF STITCHING ACROSS IT USING SIZE FF THREAD, 6 TO 9 STITCHES PER IN AND A MD SEWING MACHINE.		
6. FABRICATE POCKET FLAP FROM CLOTH AND COTTON TAPE AS SHOWN IN VIEW C. SEW AS IN 5. ABOVE.		

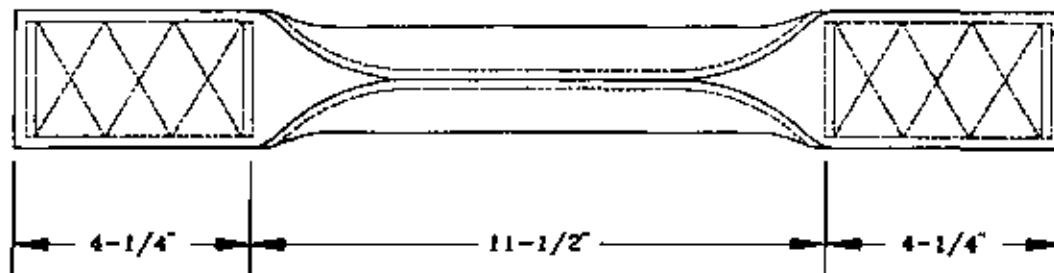

Fig. 16 (EQUIPMENT PACK AND HARNESS ASSEMBLY) HANDLE

PROCEDURE	MATERIALS	NOTE
1. FABRICATE HANDLE AS SHOWN AND SEW USING SIZE FF THREAD, 6 TO 9 STITCHES PER INCH AND A MD SEWING MACHINE.	WEBBING, NYLON, TYPE VIII THREAD, NYLON, SIZE FF	DIMENSIONS SHOWN ARE IN INCHES. TOLERANCE IS 1/8-IN.

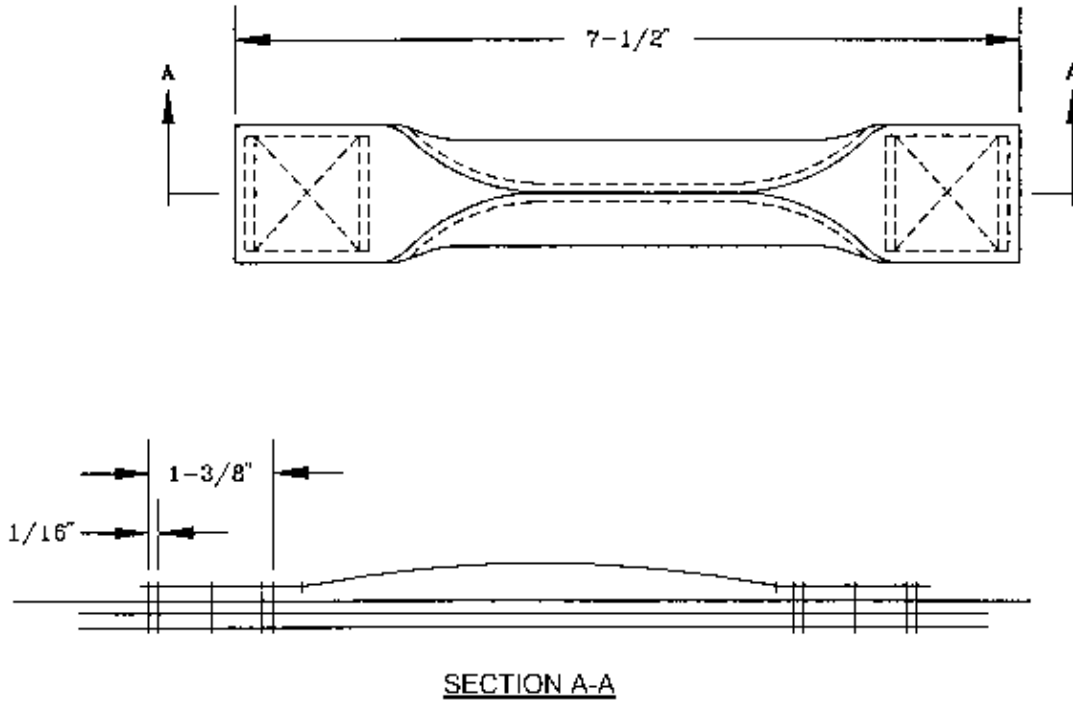

Fig. 17 (STINGER MISSILE PACK) STRAP, CARRYING

PROCEDURE	MATERIALS	NOTE
1. FABRICATE HANDLE AS SHOWN AND SEW USING SIZE 3 THREAD, 5 TO 8 STITCHES PER INCH AND A HD SEWING MACHINE.	WEBBING, NYLON, TYPE VIII THREAD, NYLON, SIZE 3	DIMENSIONS SHOWN ARE IN INCHES. TOLERANCE IS 1/8-IN.

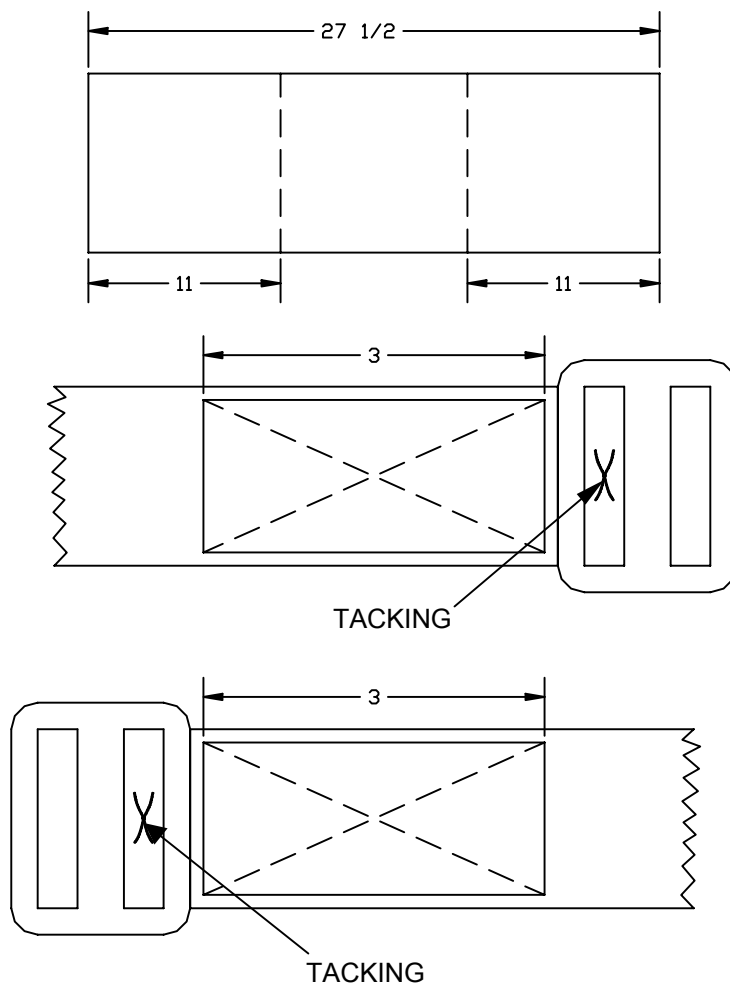
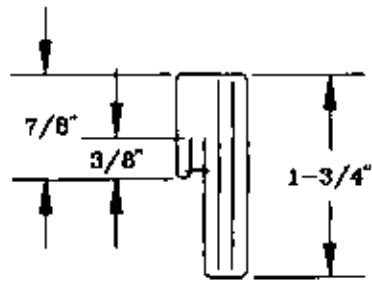
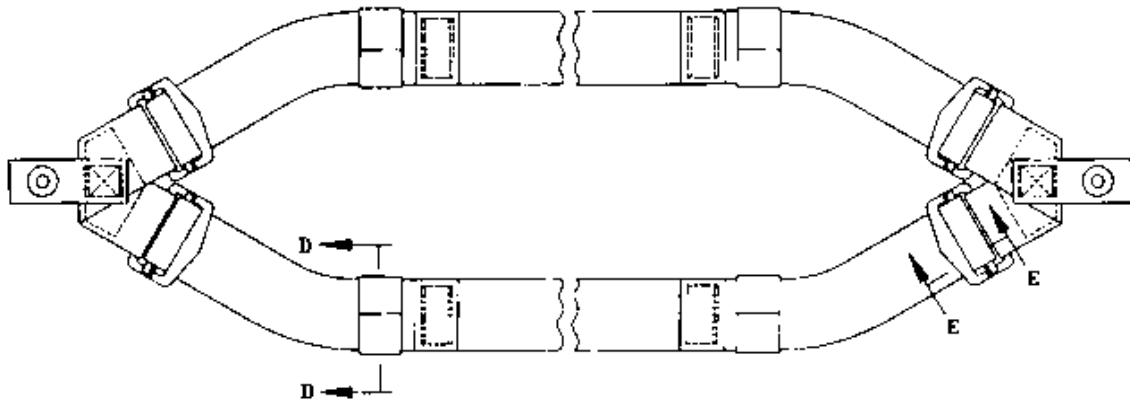

Fig. 18 (ARCTIC RIGGING EXTENSION) WAISTBAND, MODIFIED

PROCEDURE	MATERIALS	NOTE
1. CUT A 27-1/2-IN LENGTH OF TYPE X WEBBING, SEAR BOTH ENDS.	BUCKLE, 2EA, MS22014-3, 5340-00-360-0235, FC31 (FROM BER T-10 PACK TRAY)	DIMENSIONS SHOWN ARE IN INCHES.
2. PLACE MARKS 11-IN FROM THE EDGE OF BOTH ENDS.	27-1/2-IN TYPE X WEBBING.	TOLERANCE IS 1/4-IN.
3. ROUTE BUCKLE INTO WEBBING.	72-IN TYPE X WEBBING (WAISTBAND)	
4. FOLD RUNNING ENDS TO MARKS AND STITCH WITH SINGLE 3-IN BOX X STITCH FORMATION. USING SIZE 3 THREAD, 5 TO 8 STITCHES PER INCH AND A HD SEWING MACHINE	THREAD TYPE 5 NYLON CORD	THIS MODIFIED WAISTBAND STRAP IS USED IN LIEU OF THE STANDARD WAISTBAND WHEN PARACHUTING WITH SNOWSHOES.
5. HAND TACK EACH BUCKLE WITH ONE TURN DOUBLE TAPE, LACING AND TYING WITH AND OVERHAND KNOT.	TAPE, LACING, NYLON, MIL-T-43435 (SUPER TACK)	SEE FM 57-220 CHAPTER 13 FOR RIGGING PROCEDURES.
6. CUT A 72-IN LENGTH OF TYPE X WEBBING FOR THE WAISTBAND, SEAR BOTH ENDS WITH HOT KNIFE.		
7. FINISHED LENGTH OF WAISTBAND ADAPTER STRAP 16-IN.		



SECTION D-D



SECTION E-E

Fig. 19 (CONTAINER FRONT MOUNTED) HORIZONTAL RESTRAINT ASSEMBLY

PROCEDURE	MATERIALS	NOTE
1. FABRICATE HORIZONTAL RESTRAINT ASSEMBLY AS SHOWN.	WEBBING, NYLON, TYPE VIII THREAD, NYLON, SIZE 3	DIMENSIONS SHOWN ARE IN INCHES. TOLERANCE IS 1/8-IN.

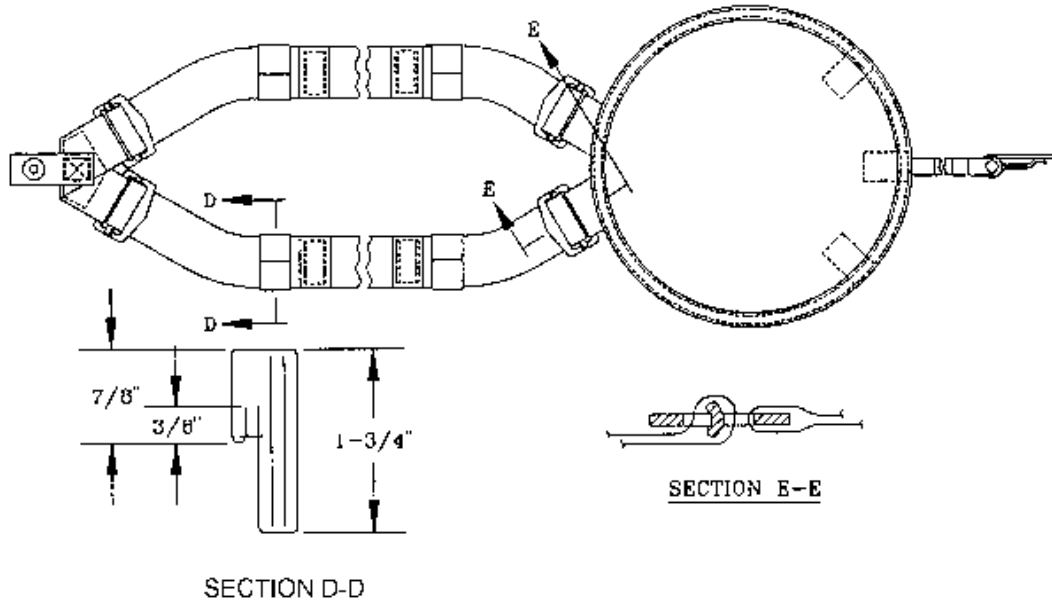

Fig. 20 (CONTAINER FRONT MOUNTED) VERTICAL RESTRAINT ASSEMBLY (SHEET 1 OF 3)

PROCEDURE	MATERIALS	NOTE
1. FABRICATE VERTICAL RESTRAINT ASSEMBLY AS SHOWN.	<p>WEBBING, NYLON, TYPE III</p> <p>THREAD, NYLON, SIZE 3</p> <p>WEBBING, NYLON, TYPE VIII</p> <p>WEBBING, NYLON, TYPE III</p> <p>WEBBING, NYLON, TYPE I</p> <p>CORD, POLYESTER, CORDLESS</p> <p>TAPE, FASTENER, PILE</p>	<p>DIMENSIONS SHOWN ARE IN INCHES.</p> <p>TOLERANCE IS 1/8-IN.</p>

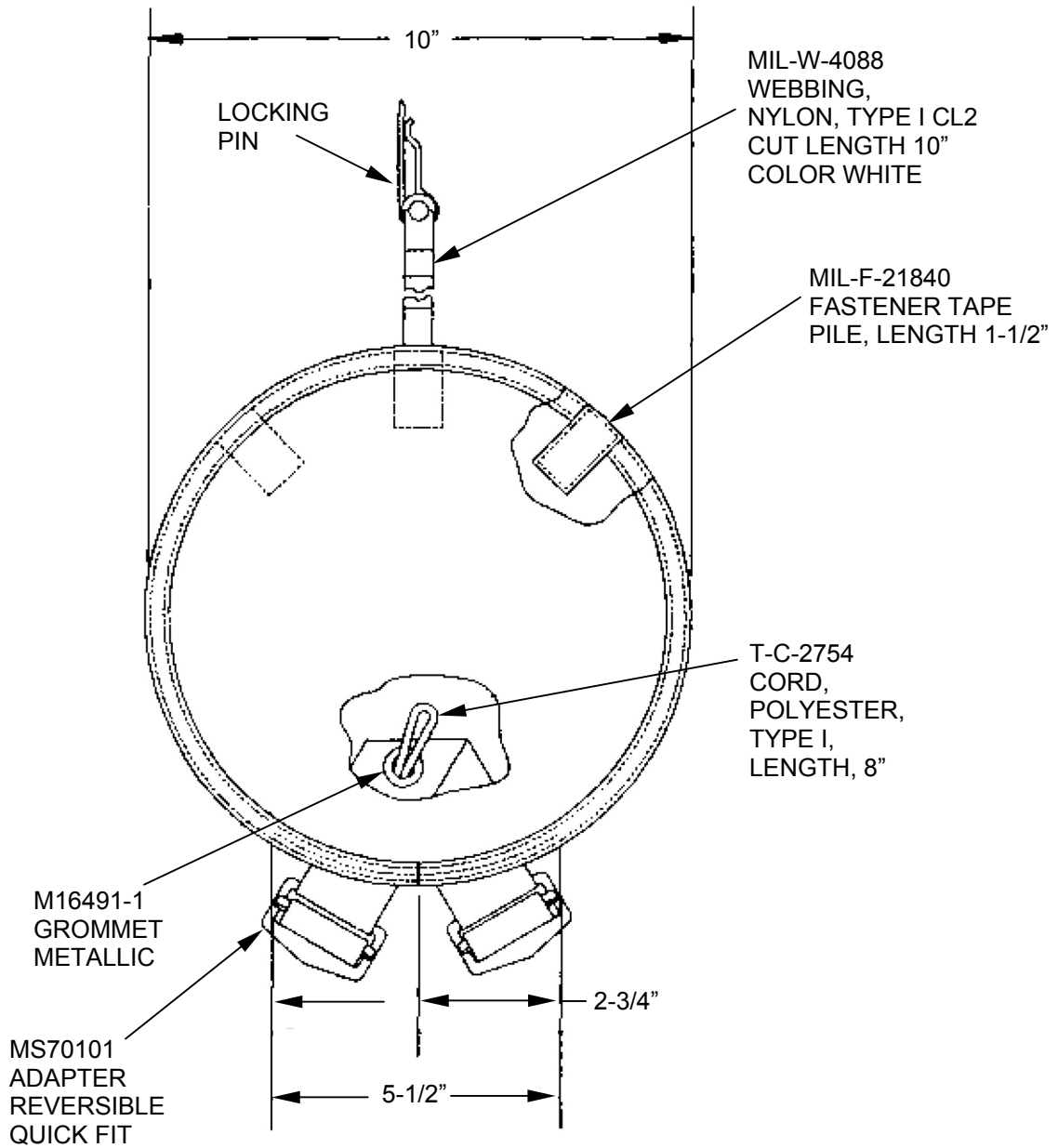

Fig. 20 (CONTAINER FRONT MOUNTED) VERTICAL RESTRAINT ASSEMBLY (SHEET 2 OF 3)

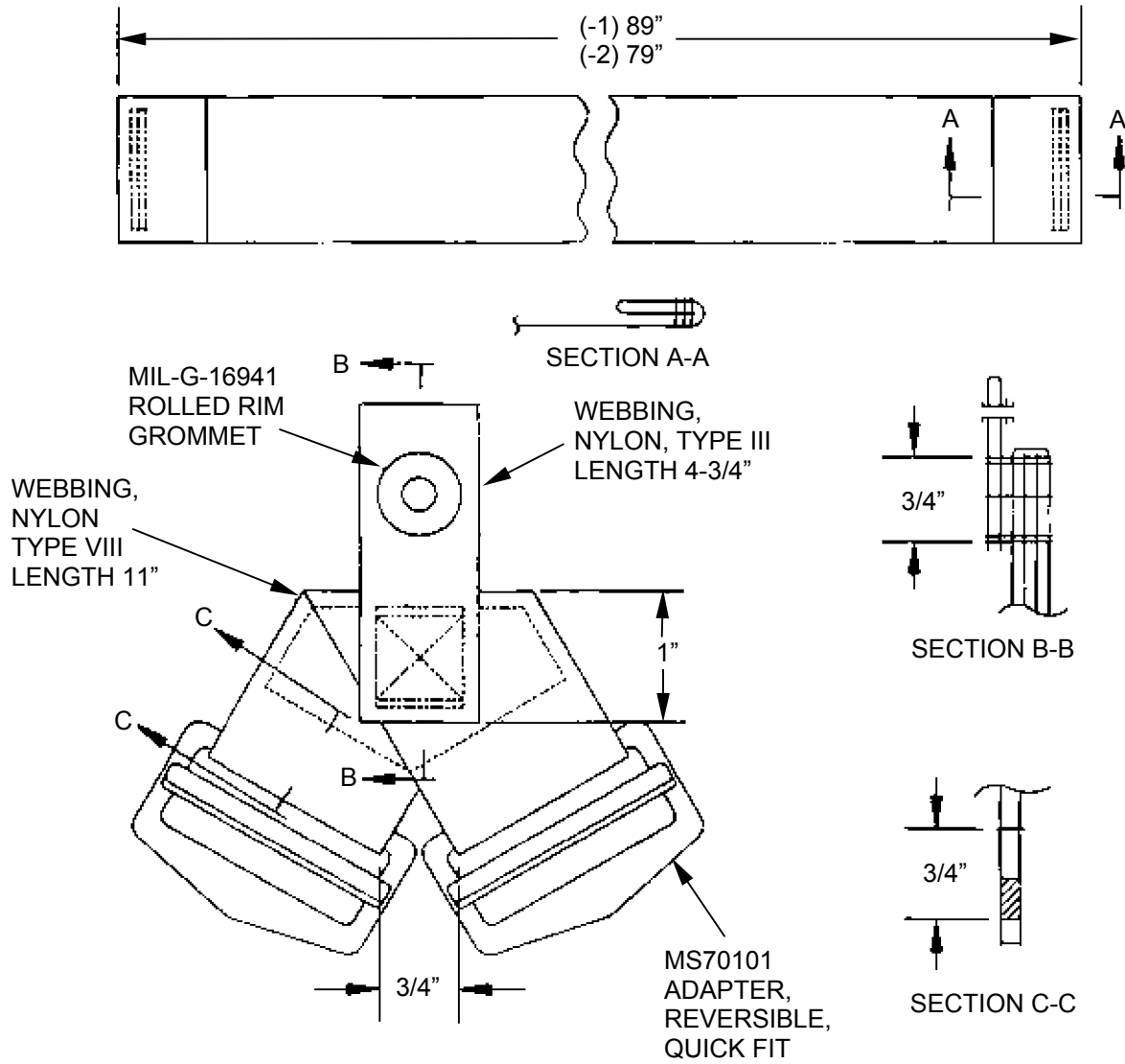

Fig. 20 (CONTAINER FRONT MOUNTED) VERTICAL RESTRAINT ASSEMBLY (SHEET 3 OF 3)

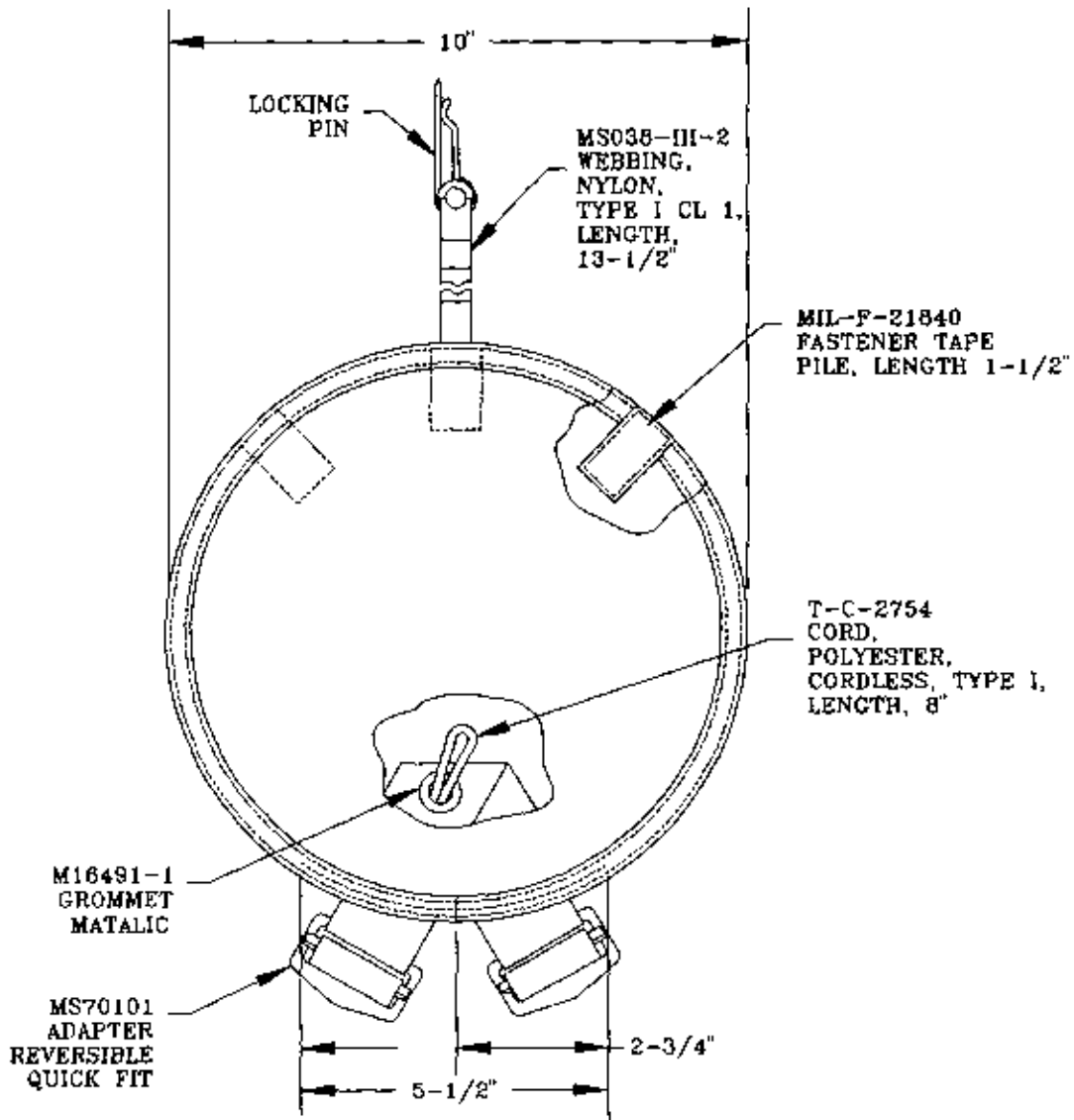

Fig. 21 (CONTAINER FRONT MOUNTED) CLOSING FLAP ASSEMBLY

PROCEDURE	MATERIALS	NOTE
1. FABRICATE CLOSING FLAP ASSEMBLY AS SHOWN.	WEBBING, NYLON, TYPE I	DIMENSIONS SHOWN ARE IN INCHES.
	CORD, POLYESTER, CORDLESS, TYPE I	TOLERANCE IS 1/8-IN.

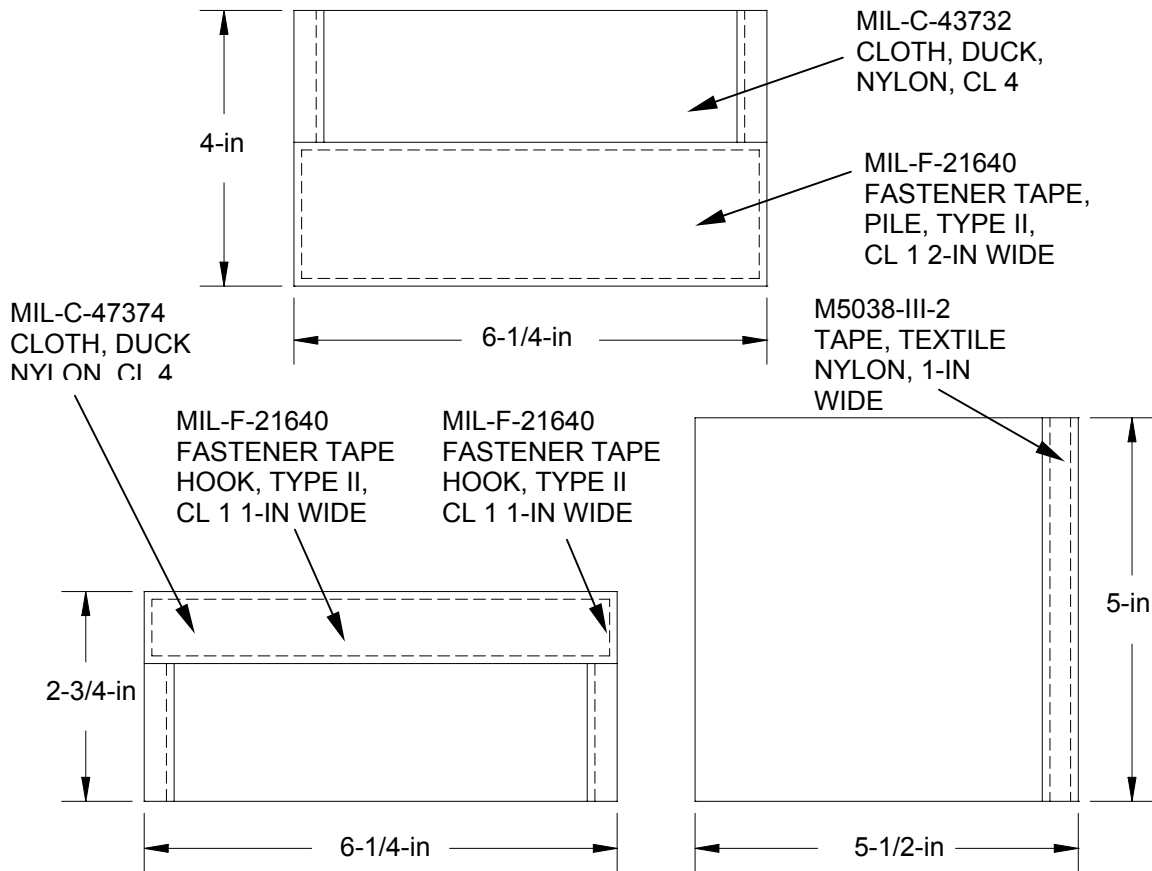

Fig. 22 (CONTAINER FRONT MOUNTED) LOWERING LINE POCKET, FLAPS AND LOOP

PROCEDURE	MATERIALS	NOTE
1. FABRICATE LOWERING LINE POCKET FLAPS AND LOOP AS SHOWN.	CLOTH, DUCK, NYLON CLASS 4.	DIMENSIONS SHOWN ARE IN INCHES.
	TAPE, FASTENER, PILE TYPE II, 2-IN WIDE	TOLERANCE IS 1/8-IN.
	TAPE, TEXTILE, NYLON 1-IN WIDE	
	TAPE, FASTENER, HOOK TYPE II, 1-IN WIDE.	

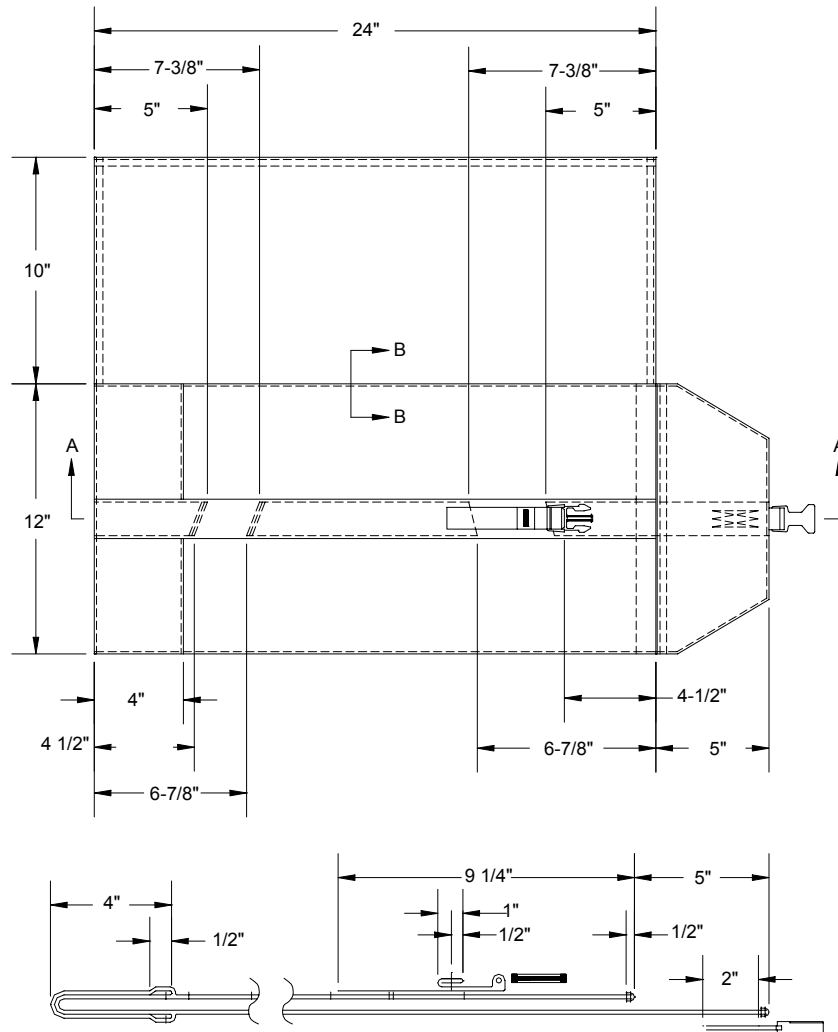

Fig. 23 (CONTAINER FRONT MOUNTED) SIDE CONTAINER ASSEMBLY

PROCEDURE	MATERIALS	NOTE
1. FABRICATE SIDE CONTAINER ASSEMBLY AS SHOWN.	CLOTH, DUCK, NYLON CLASS 4.	DIMENSIONS SHOWN ARE IN INCHES.
	TAPE, REINFORCING NYLON, 1-IN WIDE.	TOLERANCE IS 1/4-IN.
	WEBBING, NYLON TYPE VIII	
	THREAD, NYLON, SIZE 3 TYPE 301 STITCH, 5 TO 8 STITCHES PER INCH	

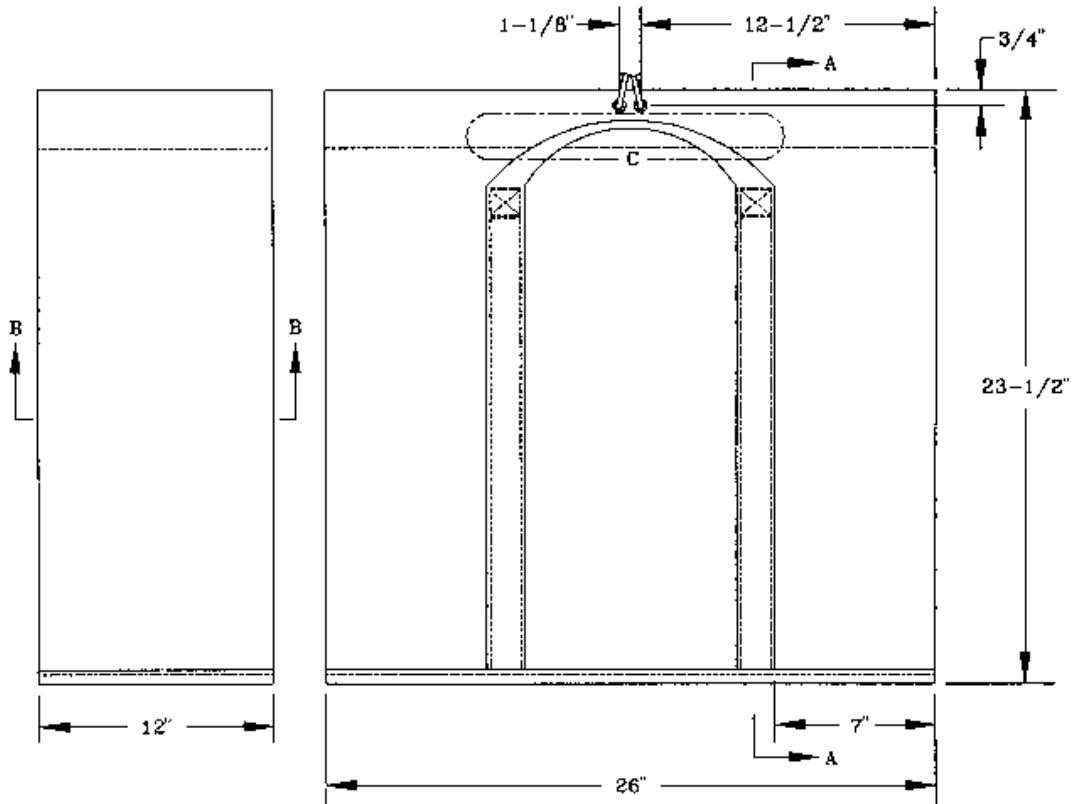

Fig. 24 (CONTAINER FRONT MOUNTED) KIT, BAG ASSEMBLY (SHEET 1 OF 2)

PROCEDURE	MATERIALS	NOTE
1. FABRICATE BAG ASSEMBLY AS SHOWN.	CLOTH, DUCK, NYLON CLASS 4. TAPE, REINFORCING NYLON, 1-IN WIDE. WEBBING, NYLON, TYPE VIII. THREAD, NYLON, SIZE FF, TYPE 301 STITCH, 6 TO 9 SPI	DIMENSIONS SHOWN ARE IN INCHES. TOLERANCE IS 1/4-IN.
2. BARTACK	SIZE E THREAD, 42-48 SPI	
3. BINDING TAPE (MIL-T-5038)	SIZE E THREAD, TYPE 301 STITCH, 7 TO 11 SPI	
4. BOX STITCH	SIZE 3 THREAD, TYPE 301 STITCH, 5 TO 8 SPI	

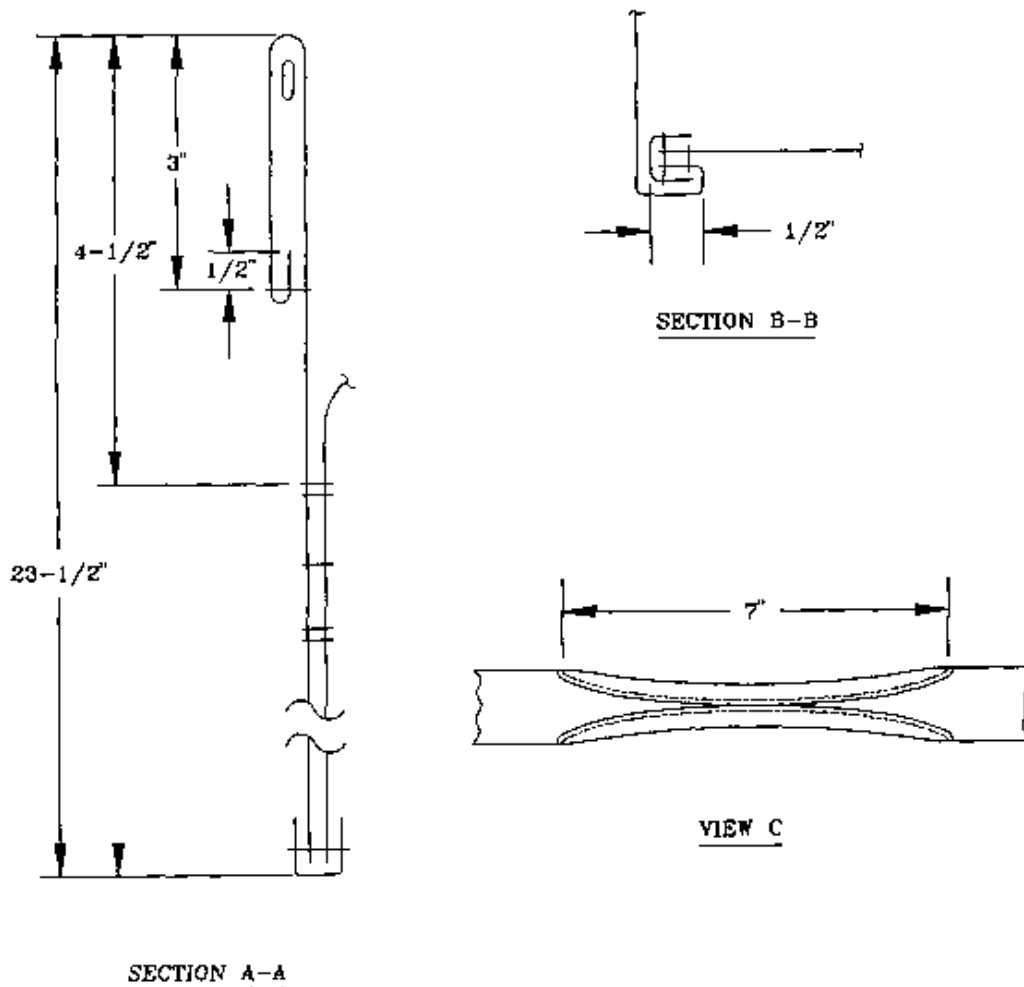

Fig. 24 (CONTAINER FRONT MOUNTED) KIT, BAG ASSEMBLY (SHEET 2 OF 2)

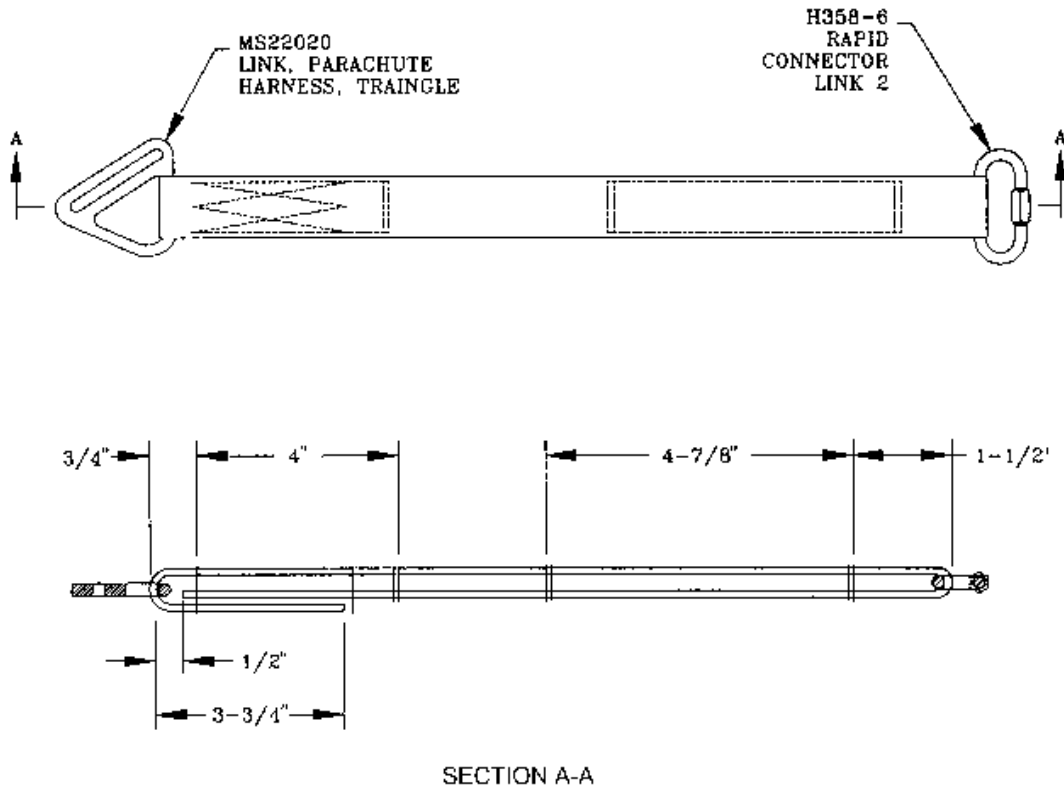

Fig. 25 (CONTAINER FRONT MOUNTED) BRIDLE ASSEMBLY

PROCEDURE	MATERIALS	NOTE
1. FABRICATE BRIDLE ASSEMBLY AS SHOWN.	WEBBING, NYLON, TUBULAR 1-IN WIDE.	DIMENSIONS SHOWN ARE IN INCHES.
	THREAD, NYLON, SIZE 3, TYPE 301 STITCH, 5 TO 8 SPI	TOLERANCE IS 1/4-IN.

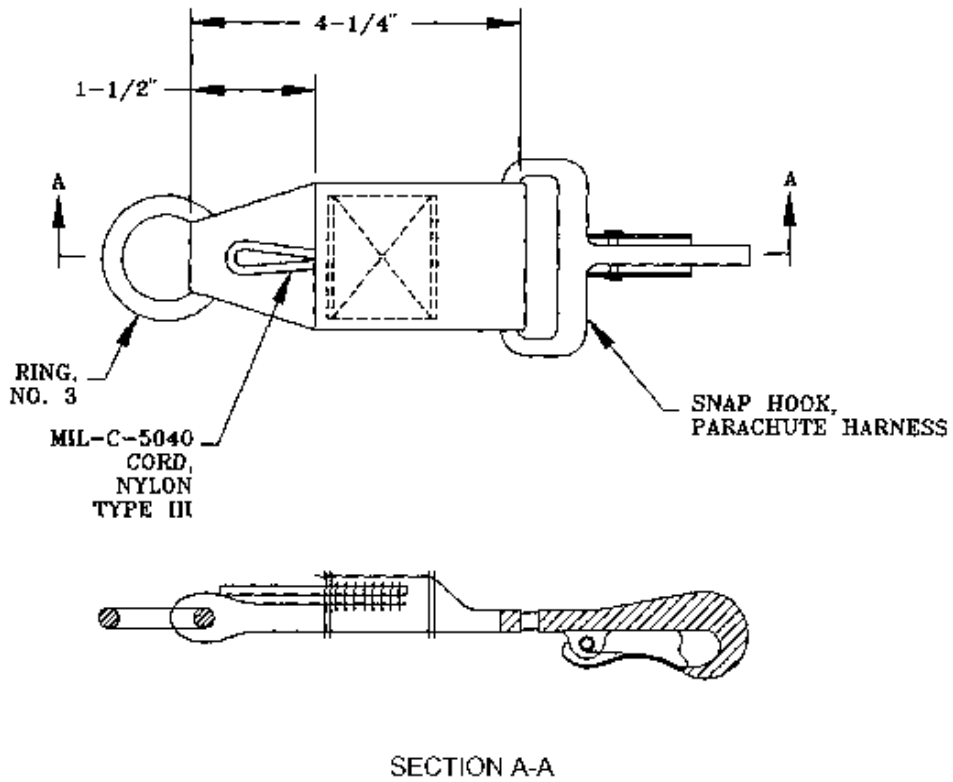

Fig. 26 (CONTAINER FRONT MOUNTED) ATTACHING STRAP

PROCEDURE	MATERIALS	NOTE
1. FABRICATE ATTACHING STRAP AS SHOWN.	WEBBING, NYLON, TYPE VII.	DIMENSIONS SHOWN ARE IN INCHES.
	THREAD, NYLON, SIZE 3	TOLERANCE IS 1/4-IN.
	CORD, NYLON, TYPE III	

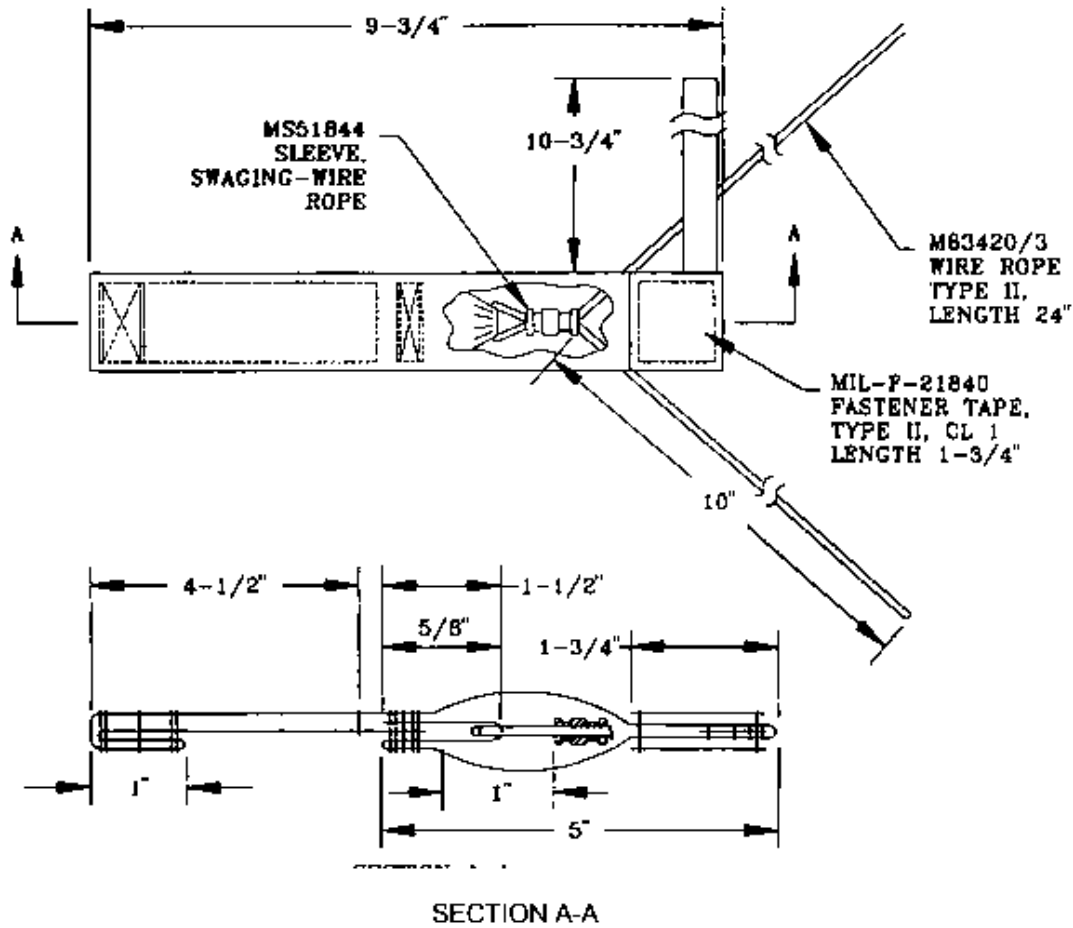

Fig. 27 (CONTAINER FRONT MOUNTED) RELEASE HANDLE ASSEMBLY

PROCEDURE	MATERIALS	NOTE
1. FABRICATE RELEASE HANDLE ASSEMBLY AS SHOWN.	WEBBING, NYLON, TYPE VIII.	DIMENSIONS SHOWN ARE IN INCHES.
	WEBBING, NYLON, TUBULAR, 1/2-IN WIDE	TOLERANCE IS 1/4-IN.
	TAPE, FASTENER, PILE TYPE II.	
	WIRE ROPE, TYPE II.	
	THREAD, NYLON, SIZE 3	

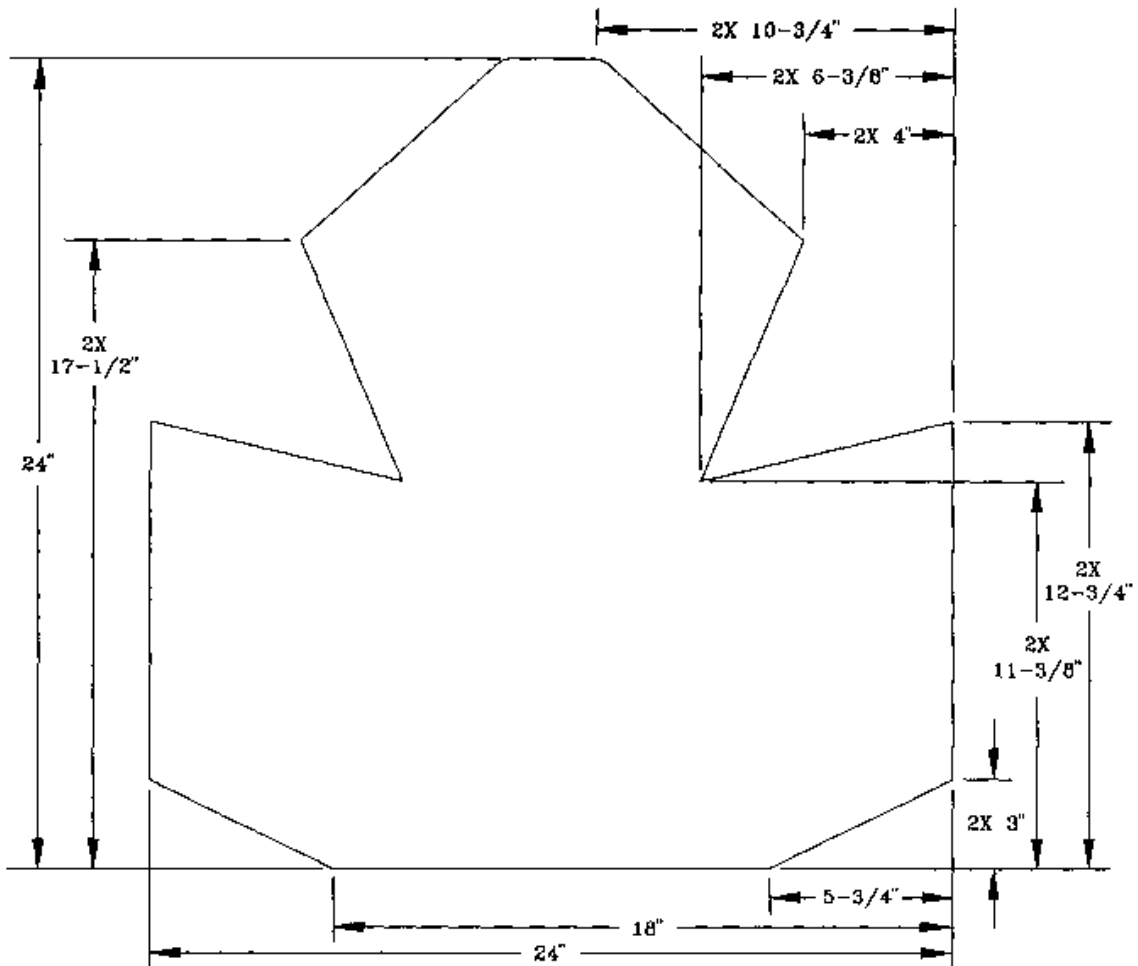

Fig. 28 (CONTAINER SIDE MOUNTED) UPPER CAP ASSEMBLY (SHEET 1 OF 2)

PROCEDURE	MATERIALS	NOTE
1. FABRICATE UPPER CAP ASSEMBLY AS SHOWN.	CLOTH, DUCK, TEXTURED TYPE VIII.	DIMENSIONS SHOWN ARE IN INCHES. TOLERANCE IS 1/4-IN.

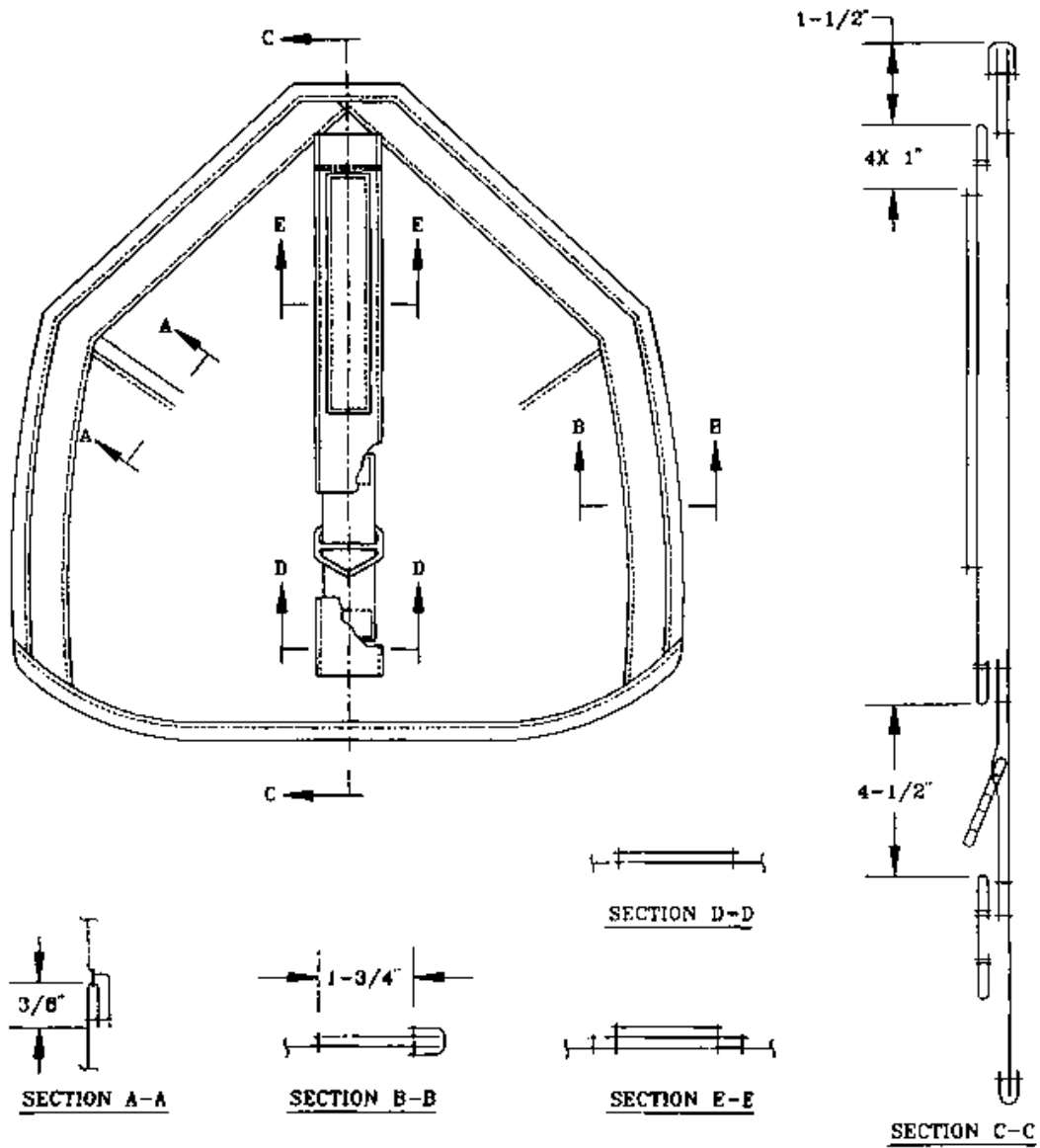

Fig. 28 (CONTAINER SIDE MOUNTED) UPPER CAP ASSEMBLY (SHEET 2 OF 2)

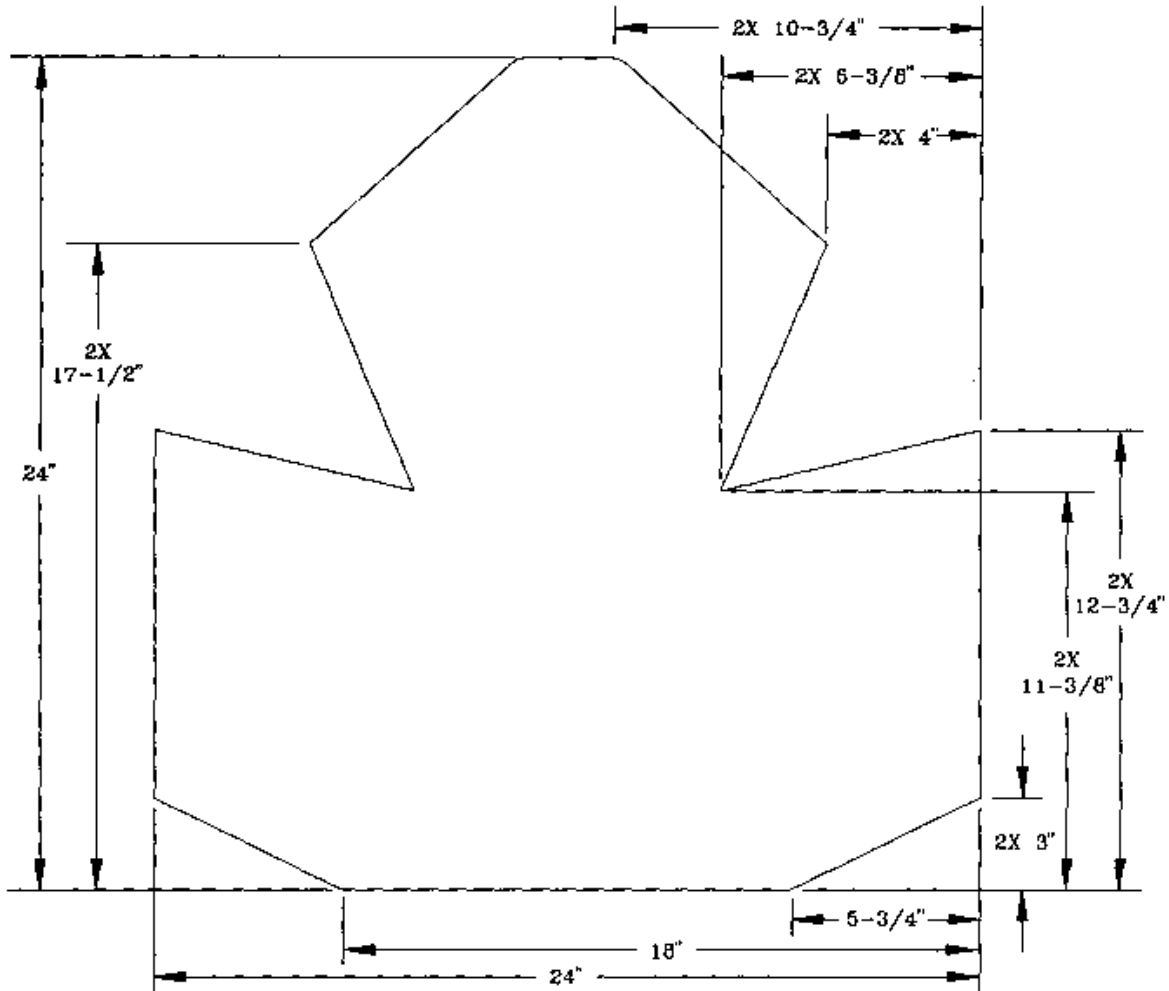

Fig. 29 (CONTAINER SIDE MOUNTED) LOWER CAP ASSEMBLY (SHEET 1 OF 2)

PROCEDURE	MATERIALS	NOTE
1. FABRICATE UPPER CAP ASSEMBLY AS SHOWN.	CLOTH, DUCK, TEXTURED TYPE VIII. SIZE FF THREAD, TYPE 301 STITCH, 6 TO 9 SPI	DIMENSIONS SHOWN ARE IN INCHES. TOLERANCE IS 1/4-IN.

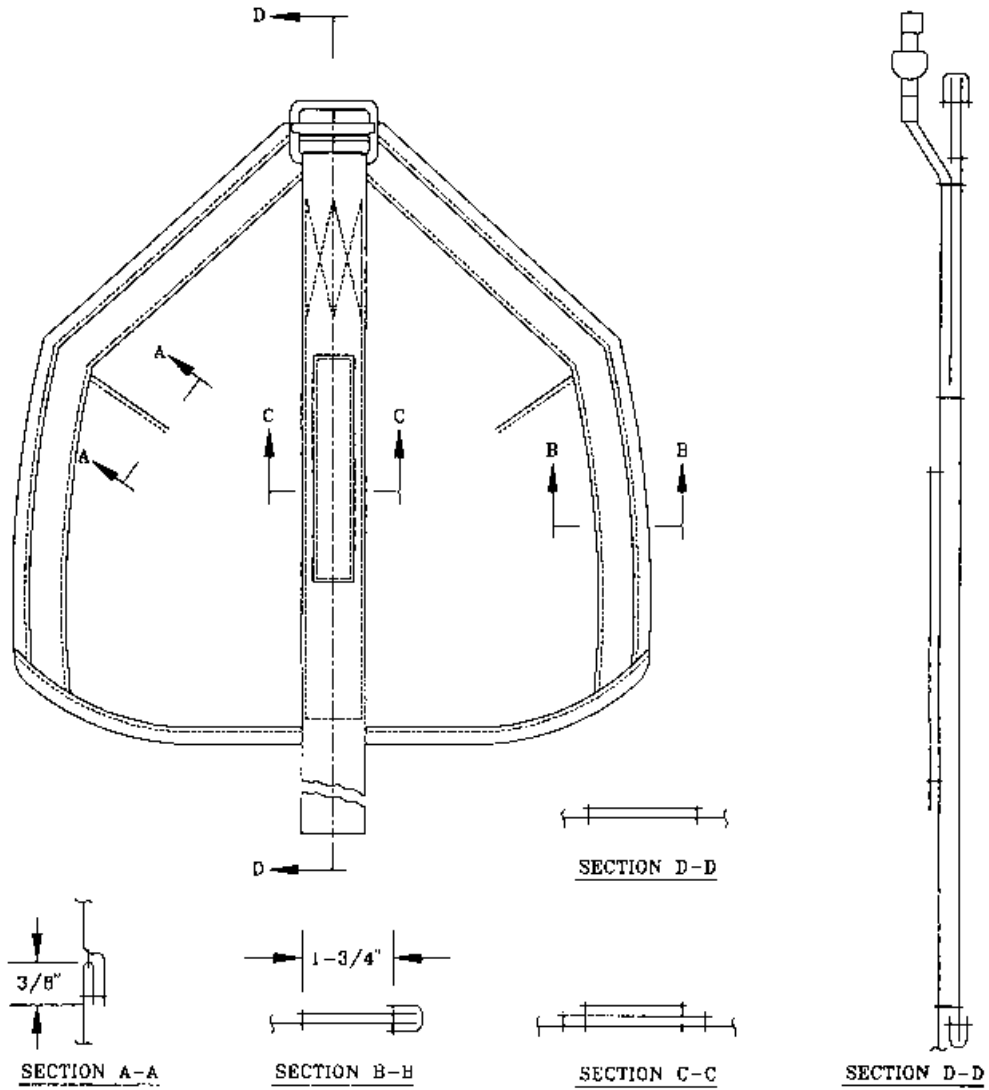
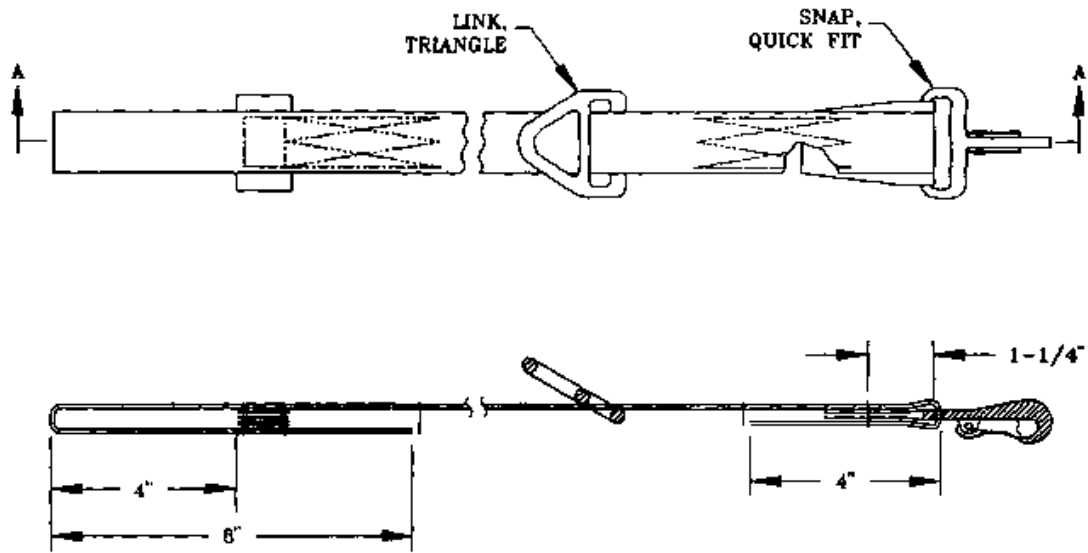

Fig. 29 (CONTAINER SIDE MOUNTED) LOWER CAP ASSEMBLY (SHEET 2 OF 2)



SECTION A-A

Fig. 30 (CONTAINER SIDE MOUNTED) LOWER LINE BRIDLE ASSEMBLY

PROCEDURE	MATERIALS	NOTE
1. FABRICATE LOWERING LINE BRIDLE ASSEMBLY AS SHOWN.	CLOTH, DUCK, TEXTURED VIII.	DIMENSIONS SHOWN ARE IN INCHES.
	THREAD, NYLON, SIZE 3, TYPE 301 STITCH, 5 TO 8 SPI	TOLERANCE IS 1/4-IN.

**UNIT SUPPORT MAINTENANCE
ANCILLARY EQUIPMENT FOR PERSONNEL TROOP PARACHUTE SYSTEM
ALPHABETICAL INDEX**

A

Abbreviations, List of.....	0001 00
Administrative Storage Requirements	0001 00
Airing	0010 00
Allocation Chart, Maintenance (MAC).....	0034 00

C

Capabilities and Features, Equipment	
Characteristics	0002 00
Characteristics, Capabilities and Features, Equipment	0002 00
Chart (MAC), Maintenance Allocation.....	0034 00
Checks and Services, Unit Preventive Maintenance.....	0005 00
Cleaning	0009 00
Common Tools and Equipment	0034 00
Corrosion Prevention and Control.....	0001 00
Cross-Reference, Nomenclature	0001 00

D

Darning.....	0012 00
Data, Equipment	0002 00
Description of Major Parts, Location and,	0002 00
Destruction of Army Equipment to Prevent Enemy Use	0001 00
Drop Bag, Parachutist.....	0002 00
Drop Testing Criteria	0005 00
Drying.....	0008 00
Durable Supplies and Materials List, Expendable	0052 00

E

Equipment Characteristics, Capabilities and Features	0002 00
Equipment Data	0002 00
Equipment Improvement Recommendations (EIR) Reporting.....	0001 00
Expendable/Durable Supplies and Materials List	0052 00

F

Features, Equipment Characteristics, and Capabilities	0002 00
Forms and Procedures, Maintenance.....	0004 00

G

General Information	0001 00
General Maintenance Procedures	0005 00

I

Illustrated List of Manufactured Items Introduction	0053 00
Improvement Recommendations (EIR), Reporting Equipment.....	0001 00
Initial Receipt.....	0004 00
INSPECT-	
Accessory Set, SCUBA.....	0017 00
Case, Parachutist's Individual Weapon M-1950 (Cotton).....	0022 00
Case, Parachutist's Individual Weapon M01950 (Nylon).....	0023 00
Container, Front Mounted	0027 00
Container, Side Mounted	0028 00
5 Foot Extension Static Line	0016 00
Harness, Single Point Release	0020 00
Jump Pack, Dragon Missile	0019 00
Jump Pack, Stinger Missile.....	0025 00
Line, Lowering.....	0018 00
Pack Assembly, AT4.....	0021 00
Parachutist Drop Bag (PDB).....	0029 00
Parachutist's Weapons and Individual Equipment Pack and Harness Assembly	0024 00
Release Assembly	0026 00
Inspecting Unpacked Equipment	0008 00
Inspection and Disposition	0008 00
Inspection Rigger/Technical.....	0008 00
INSTALL-	
Accessory Set, SCUBA.....	0017 00
5 Foot Extension Static Line	0016 00
Parachutist Drop Bag (PDB).....	0029 00
Introduction to PMCS.....	0005 00

L

List of Abbreviations	0001 00
Location and Description of Major Components	0002 00
Long Term Storage and Shipment.....	0001 00
Lowering Line.....	0002 00
Lubrication.....	0006 00

M

Maintenance Allocation Chart (MAC).....	0034 00
Maintenance Forms and Procedures.....	0001 00
Maintenance Procedures, General, Unit.....	0005 00
Major Components, Location and Description of.....	0002 00
Marking and Restenciling.....	0014 00
Materials List, Expendable/Durable Supplies and	0050 00

N

Nomenclature Cross-Reference List.....	0001 00
--	---------

P

Patching	0012 00
Painting	0014 00
Parts and Special Tools List, Repair.....	0035 00
PMCS Table, Introduction.....	0005 00
Preparation for Storage and/or Shipment	0001 00
Preparation for Storage.....	0030 00

Preparation for Shipment	0031 00
Preventative Maintenance Checks and Services	0001 00
Principles of Operation For The Parachute Drop Bag (PDB)	0003 00

R

Records, Maintenance, Forms and	0004 00
References	0032 00

REPAIR-

Accessory Set, SCUBA	0017 00
Case, Parachutist's Individual Weapon M-1950 (Cotton)	0022 00
Case, Parachutist's Individual Weapon M-1950 (Nylon)	0023 00
Container, Front Mounted	0027 00
Container, Side Mounted	0028 00
5 Foot Extension Static Line	0016 00
Harness, Single Point Release	0020 00
Jump Pack, Dragon Missile	0019 00
Jump Pack, Stinger Missile	0025 00
Line, Lowering	0018 00
Pack Assembly, AT4	0021 00
Parachutist Drop Bag (PDB)	0029 00
Parachutist's Weapons and Individual Equipment Pack and Harness Assembly	0024 00
Release Assembly	0026 00
Snap Fastener and Grommets	0015 00
Repair, General Instructions	0005 00
Repair Parts	0035 00
Repair Parts and Special Tools List	0035 00
Reporting Equipment Improvement Recommendations (EIR)	0001 00

REPLACE-

Accessory Set, SCUBA	0017 00
Case, Parachutist's Individual Weapon M-1950 (Cotton)	0022 00
Case, Parachutist's Individual Weapon M-1950 (Nylon)	0023 00
Container, Front Mounted	0027 00
Container, Side Mounted	0028 00
5 Foot Extension Static Line	0016 00
Harness, Single Point Release	0020 00
Jump Pack, Dragon Missile	0019 00
Jump Pack, Stinger Missile	0025 00
Line, Lowering	0018 00
Pack Assembly, AT4	0021 00
Parachutist Drop Bag (PDB)	0029 00
Parachutist's Weapons and Individual Equipment Pack and Harness Assembly	0024 00
Release Assembly	0026 00
Snap Fastener and Grommets	0015 00

S

Safety, Care and Handling	0001 00
Salt/Fresh-water Contamination Test	0011 00
Scope	0001 00
Searing and Waxing	0013 00

SERVICE-

Accessory Set, SCUBA.....	0017 00
Service Upon Receipt	0007 00
Sewing Procedures	0012 00
Shipment, Preparation for	0031 00
Special Tools.....	0035 00
Special Instructions for Administrative Storage	0030 00
Stenciling.....	0014 00
Stitching.....	0012 00
Storage, Long Term, Preparation for	0030 00
Supplies and Materials List	
Expendable/Durable.....	0052 00

T

Technical/Rigger Type Inspection.....	0008 00
Terms, List of Abbreviations and	0001 00
Theory of Operation	0003 00
Tools and Equipment, Common	0034 00

U

Unit Maintenance Procedures, General.....	0007 00
Unit Preventive Maintenance Checks and Services (PMCS)	0005 00
Unpacked Equipment, Inspecting	0008 00
Unpacking	0004 00

W

Warnings, Cautions, and Notes	0001 00
Warranty Information.....	0001 00
Waxing	0013 00

By Order of the Secretaries of the Army, Air Force and Navy (Including the Marine Corps):

PETER J. SCHOOMAKER
General, United States Army
Chief of Staff

Official:

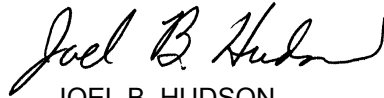

JOEL B. HUDSON
Administrative Assistant to the
Secretary of the Army
0415601

MICHAEL E. RYAN
General, USAF
Chief of Staff

Official:

GEORGE T. BABBETT
General, USAF
Commander, Air Force Materiel Command

D.G. MORRAL
Rear Admiral, USN
Program Executive Officer
For Expeditionary Warfare
Naval Sea Systems Command

R.P. SHOCKEY
Director, Program Support
Marine Corps Systems Command

DISTRIBUTION:

To be distributed in accordance with Initial Distribution Number (IDN) 256295 requirements for TM 10-1670-299-20&P.

These are the instructions for sending an electronic 2028

The following format must be used if submitting an electronic 2028. The subject line must be exactly the same and all fields must be included; however only the following fields are mandatory: 1, 3, 4, 5, 6, 7, 8, 9, 10, 13, 15, 16, 17, and 27.

From: "Whomever" <whomever@avma27.army.mil>
To: amssbriml@natick.army.mil

Subject: DA Form 2028

1. From: Joe Smith
2. Unit: home
3. Address: 4300 Park
4. City: Hometown
5. St: MO
6. Zip: 77777
7. Date Sent: 19-OCT-93
8. Pub no: 55-2840-229-23
9. Pub Title: TM
10. Publication Date: 04-JUL-85
11. Change Number: 7
12. Submitter Rank: MSG
13. Submitter FName: Joe
14. Submitter MName: T
15. Submitter LName: Smith
16. Submitter Phone: 123-123-1234
17. Problem: 1
18. Page: 2
19. Paragraph: 3
20. Line: 4
21. NSN: 5
22. Reference: 6
23. Figure: 7
24. Table: 8
25. Item: 9
26. Total: 123
27. Text:

This is the text for the problem below line 27.

RECOMMENDED CHANGES TO PUBLICATIONS AND BLANK FORMS For use of this form, see AR 25-30; the proponent agency is ODISC4.						Use Part II (reverse) for Repair Parts and Special Tool Lists (RPSTL) and Supply Catalogs/Supply Manuals (SC/SM).	DATE 21 October 2003
TO: (Forward to proponent of publication or form) (Include ZIP Code) COMMANDER U.S. ARMY TANK-AUTOMOTIVE AND ARMAMENT COMMAND ATTN: AMSTA-LC-CECT KANSAS STREET NATICK, MA 01760-5052						FROM: (Activity and location) (Include ZIP Code) <i>PFC Jane Doe</i> <i>CO A 3rd Engineer BR</i> <i>Ft. Leonardwood, MO 63108</i>	
PART I – ALL PUBLICATIONS (EXCEPT RPSTL AND SC/SM) AND BLANK FORMS							
PUBLICATION/FORM NUMBER TM 10-1670-296-23&P				DATE 30 October 2002	TITLE Unit Manual for Ancillary Equipment for Low Velocity Air Drop Systems		
ITEM NO.	PAGE NO.	PARA-GRAPH	LINE NO. *	FIGURE NO.	TABLE NO.	RECOMMENDED CHANGES AND REASON <i>(Provide exact wording of recommended changes, if possible).</i>	
	0036 00-2				1	<i>In table 1, Sewing Machine Code Symbols, the second sewing machine code symbol should be MD ZZ not MD 22.</i> <i>Change the manual to show Sewing Machine, Industrial: Zig-Zag; 308 stitch; medium-duty; NSN 3530-01-181-1421 as a MD ZZ code symbol.</i>	
<small>*Reference to line numbers within the paragraph or subparagraph.</small>							
TYPED NAME, GRADE OR TITLE Jane Doe, PFC				TELEPHONE EXCHANGE/AUTOVON, PLUS EXTENSION 508-233-4141		SIGNATURE Jane Doe <i>Jane Doe</i>	

TO: <i>(Forward direct to addressee listed in publication)</i> COMMANDER U.S. ARMY TANK –AUTOMOTIVE AND ARMAMENT COMMAND ATTN: AMSTA-LC-CECT KANSAS STREET NATICK, MA 01760-5052	FROM: <i>(Activity and location) (Include ZIP Code)</i> <i>PFC Jane Doe</i> <i>CO A 3rd Engineer BR</i> <i>Ft. Leonardwood, MO 63108</i>	DATE 21 October 2003
--	---	--------------------------------

PART II – REPAIR PARTS AND SPECIAL TOOL LISTS AND SUPPLY CATALOGS/SUPPLY MANUALS

PUBLICATION NUMBER TM 10-1670-296-23&P	DATE 30 October 2002	TITLE Unit Manual for Ancillary Equipment for Low Velocity Air Drop Systems
--	--------------------------------	---

PAGE NO.	COLM NO.	LINE NO.	NATIONAL STOCK NUMBER	REFERENCE NO.	FIGURE NO.	ITEM NO.	TOTAL NO. OF MAJOR ITEMS SUPPORTED	RECOMMENDED ACTION
0066 00-1					4			<i>Callout 16 in figure 4 is pointed to a <u>D-Ring</u>. In the Repair Parts List key for figure 4, item 16 is called a <u>Snap Hook</u>. Please correct one or the other.</i>

PART III – REMARKS

(Any general remarks or recommendations, or suggestions for improvement of publications and blank forms. Additional blank sheets may be used if more space is needed.)

--	--	--

TYPED NAME, GRADE OR TITLE	TELEPHONE EXCHANGE/AUTOVON, PLUS EXTENSION	SIGNATURE
----------------------------	--	-----------

RECOMMENDED CHANGES TO PUBLICATIONS AND BLANK FORMS						Use Part II (reverse) for Repair Parts and Special Tool Lists (RPSTL) and Supply Catalogs/Supply Manuals (SC/SM).	DATE
For use of this form, see AR 25-30; the proponent agency is ODISC4.							
TO: (Forward to proponent of publication or form) (Include ZIP Code) Commander, U.S. Army Tank-automotive & Armament Command ATTN: AMSTA LC-CECT, Kansas Street Natick, MA 01760-5052						FROM: (Activity and location) (Include ZIP Code)	
PART I – ALL PUBLICATIONS (EXCEPT RPSTL AND SC/SM) AND BLANK FORMS							
PUBLICATION/FORM NUMBER TM 10-1670-299-20&P						DATE June 30, 2004	TITLE Unit Maintenance Manual including Repair Parts and Specials Tools List (RPSTL) Ancillary Equipment for: Personnel Troop Parachute System
ITEM NO.	PAGE NO.	PARA-GRAPH	LINE NO. *	FIGURE NO.	TABLE NO.	RECOMMENDED CHANGES AND REASON (Provide exact wording of recommended changes, if possible).	
*Reference to line numbers within the paragraph or subparagraph.							
TYPED NAME, GRADE OR TITLE					TELEPHONE EXCHANGE/AUTOVON, PLUS EXTENSION		SIGNATURE

TO: <i>(Forward direct to addressee listed in publication)</i>	FROM: <i>(Activity and location) (Include ZIP Code)</i>	DATE
---	--	-------------

PART II – REPAIR PARTS AND SPECIAL TOOL LISTS AND SUPPLY CATALOGS/SUPPLY MANUALS

PUBLICATION NUMBER				DATE			TITLE	
PAGE NO.	COLM NO.	LINE NO.	NATIONAL STOCK NUMBER	REFERENCE NO.	FIGURE NO.	ITEM NO.	TOTAL NO. OF MAJOR ITEMS SUPPORTED	RECOMMENDED ACTION

PART III – REMARKS *(Any general remarks or recommendations, or suggestions for improvement of publications and blank forms. Additional blank sheets may be used if more space is needed.)*

--

TYPED NAME, GRADE OR TITLE	TELEPHONE EXCHANGE/AUTOVON, PLUS EXTENSION	SIGNATURE
----------------------------	--	-----------

RECOMMENDED CHANGES TO PUBLICATIONS AND BLANK FORMS						Use Part II (<i>reverse</i>) for Repair Parts and Special Tool Lists (RPSTL) and Supply Catalogs/Supply Manuals (SC/SM).	DATE
For use of this form, see AR 25-30; the proponent agency is ODISC4.							
TO: (<i>Forward to proponent of publication or form</i>) (<i>Include ZIP Code</i>) Commander, U.S. Army Tank-automotive & Armament Command ATTN: AMSTA LC-CECT, Kansas Street Natick, MA 01760-5052						FROM: (<i>Activity and location</i>) (<i>Include ZIP Code</i>)	
PART I – ALL PUBLICATIONS (EXCEPT RPSTL AND SC/SM) AND BLANK FORMS							
PUBLICATION/FORM NUMBER TM 10-1670-299-20&P					DATE June 30, 2004	TITLE Unit Maintenance Manual including Repair Parts and Specials Tools List (RPSTL) Ancillary Equipment for: Personnel Troop Parachute System	
ITEM NO.	PAGE NO.	PARA-GRAPH	LINE NO. *	FIGURE NO.	TABLE NO.	RECOMMENDED CHANGES AND REASON <i>(Provide exact wording of recommended changes, if possible).</i>	
<i>*Reference to line numbers within the paragraph or subparagraph.</i>							
TYPED NAME, GRADE OR TITLE					TELEPHONE EXCHANGE/AUTOVON, PLUS EXTENSION		SIGNATURE

TO: <i>(Forward direct to addressee listed in publication)</i>				FROM: <i>(Activity and location) (Include ZIP Code)</i>				DATE	
PART II – REPAIR PARTS AND SPECIAL TOOL LISTS AND SUPPLY CATALOGS/SUPPLY MANUALS									
PUBLICATION NUMBER					DATE			TITLE	
PAGE NO.	COLM NO.	LINE NO.	NATIONAL STOCK NUMBER	REFERENCE NO.	FIGURE NO.	ITEM NO.	TOTAL NO. OF MAJOR ITEMS SUPPORTED	RECOMMENDED ACTION	
PART III – REMARKS <i>(Any general remarks or recommendations, or suggestions for improvement of publications and blank forms. Additional blank sheets may be used if more space is needed.)</i>									
TYPED NAME, GRADE OR TITLE				TELEPHONE EXCHANGE/AUTOVON, PLUS EXTENSION				SIGNATURE	

RECOMMENDED CHANGES TO PUBLICATIONS AND BLANK FORMS						Use Part II (reverse) for Repair Parts and Special Tool Lists (RPSTL) and Supply Catalogs/Supply Manuals (SC/SM).	DATE
For use of this form, see AR 25-30; the proponent agency is ODISC4.							
TO: (Forward to proponent of publication or form) (Include ZIP Code) Commander, U.S. Army Tank-automotive & Armament Command ATTN: AMSTA LC-CECT, Kansas Street Natick, MA 01760-5052						FROM: (Activity and location) (Include ZIP Code)	
PART I – ALL PUBLICATIONS (EXCEPT RPSTL AND SC/SM) AND BLANK FORMS							
PUBLICATION/FORM NUMBER TM 10-1670-299-20&P					DATE June 30, 2004	TITLE Unit Maintenance Manual including Repair Parts and Specials Tools List (RPSTL) Ancillary Equipment for: Personnel Troop Parachute System	
ITEM NO.	PAGE NO.	PARA-GRAPH	LINE NO. *	FIGURE NO.	TABLE NO.	RECOMMENDED CHANGES AND REASON (Provide exact wording of recommended changes, if possible).	
*Reference to line numbers within the paragraph or subparagraph.							
TYPED NAME, GRADE OR TITLE					TELEPHONE EXCHANGE/AUTOVON, PLUS EXTENSION		SIGNATURE

TO: <i>(Forward direct to addressee listed in publication)</i>	FROM: <i>(Activity and location) (Include ZIP Code)</i>	DATE
---	--	-------------

PART II – REPAIR PARTS AND SPECIAL TOOL LISTS AND SUPPLY CATALOGS/SUPPLY MANUALS

PUBLICATION NUMBER				DATE			TITLE	
PAGE NO.	COLM NO.	LINE NO.	NATIONAL STOCK NUMBER	REFERENCE NO.	FIGURE NO.	ITEM NO.	TOTAL NO. OF MAJOR ITEMS SUPPORTED	RECOMMENDED ACTION

PART III – REMARKS *(Any general remarks or recommendations, or suggestions for improvement of publications and blank forms. Additional blank sheets may be used if more space is needed.)*

--

TYPED NAME, GRADE OR TITLE	TELEPHONE EXCHANGE/AUTOVON, PLUS EXTENSION	SIGNATURE
----------------------------	--	-----------

The Metric System and Equivalents

Linear Measure

1 centimeter = 10 millimeters = .39 inch
 1 decimeter = 10 centimeters = 3.94 inches
 1 meter = 10 decimeters = 39.37 inches
 1 dekameter = 10 meters = 32.8 feet
 1 hectometer = 10 dekameters = 328.08 feet
 1 kilometer = 10 hectometers = 3,280.8 feet

Weights

1 centigram = 10 milligrams = .15 grain
 1 decigram = 10 centigrams = 1.54 grains
 1 gram = 10 decigrams = .035 ounce
 1 dekagram = 10 grams = .35 ounce
 1 hectogram = 10 dekagrams = 3.52 ounces
 1 kilogram = 10 hectograms = 2.2 pounds
 1 quintal = 100 kilograms = 220.46 pounds
 1 metric ton = 10 quintals = 1.1 short tons

Liquid Measure

1 centiliter = 10 milliliters = .34 fl. ounce
 1 deciliter = 10 centiliters = 3.38 fl. ounces
 1 liter = 10 deciliters = 33.81 fl. ounces
 1 dekaliter = 10 liters = 2.64 gallons
 1 hectoliter = 10 dekaliters = 26.42 gallons
 1 kiloliter = 10 hectoliters = 264.18 gallons

Square Measure

1 sq. centimeter = 100 sq. millimeters = .15 sq. inch
 1 sq. decimeter = 100 sq. centimeters = 15.5 sq. inches
 1 sq. meter (centare) = 100 sq. decimeters = 10.76 sq. feet
 1 sq. dekameter (are) = 100 sq. meters = 1,076.4 sq. feet
 1 sq. hectometer (hectare) = 100 sq. dekameters = 2.47 acres
 1 sq. kilometer = 100 sq. hectometers = .386 sq. mile

Cubic Measure

1 cu. centimeter = 1000 cu. millimeters = .06 cu. inch
 1 cu. decimeter = 1000 cu. centimeters = 61.02 cu. inches
 1 cu. meter = 1000 cu. decimeters = 35.31 feet

Approximate Conversion Factors

<i>To change</i>	<i>To</i>	<i>Multiply by</i>	<i>To change</i>	<i>To</i>	<i>Multiply by</i>
inches	centimeters	2.540	ounce-inches	newton-meters	.007062
feet	meters	.305	centimeters	inches	.394
yards	meters	.914	meters	feet	3.280
miles	kilometers	1.609	meters	yards	1.094
square inches	square centimeters	6.451	kilometers	miles	.621
square feet	square meters	.093	square centimeters	square inches	.155
square yards	square meters	.836	square meters	square feet	10.764
square miles	square kilometers	2.590	square meters	square yards	1.196
acres	square hectometers	.405	square kilometers	square miles	.386
cubic feet	cubic meters	.028	square hectometers	acres	2.471
cubic yards	cubic meters	.765	cubic meters	cubic feet	35.315
fluid ounces	milliliters	29.573	cubic meters	cubic yards	1.308
pints	liters	.473	milliliters	fluid ounces	.034
quarts	liters	.946	liters	pints	2.113
gallons	liters	3.785	liters	quarts	1.057
ounces	grams	28.349	liters	gallons	.264
pounds	kilograms	.454	grams	ounces	.035
short tons	metric tons	.907	kilograms	pounds	2.205
pound-feet	newton-meters	1.356	metric tons	short tons	1.102
pound-inches	newton-meters	.11296			

Temperature (Exact)

 °F Fahrenheit temperature $\times \frac{5}{9}$ (after subtracting 32) = Celsius temperature °C

PIN: 074105-000